

INSTALLATION INSTRUCTIONS

1. DESCRIPTION: Front Aero Bumper

2. APPLICATION: Q70

3. PART NUMBER: K6020 1MAxx

4. KIT CONTENTS:

Item	Qty	Part Name
①	1	Front Aero Bumper
②	1	Lwer Grille LH A
③	1	Lwer Grille LH B
④	1	License Plete Bracket
⑤	2	Bolt
⑥	2	Screw Grommet
⑦	4	Spring Nut
⑧	1each	End Cap (RH/LH)
⑨	6	Clip
⑩	4	Tapping Screw
⑪	1each	Fog Lump Finisher (RH/LH)
⑫	1	Installation Instruction Replacement Template

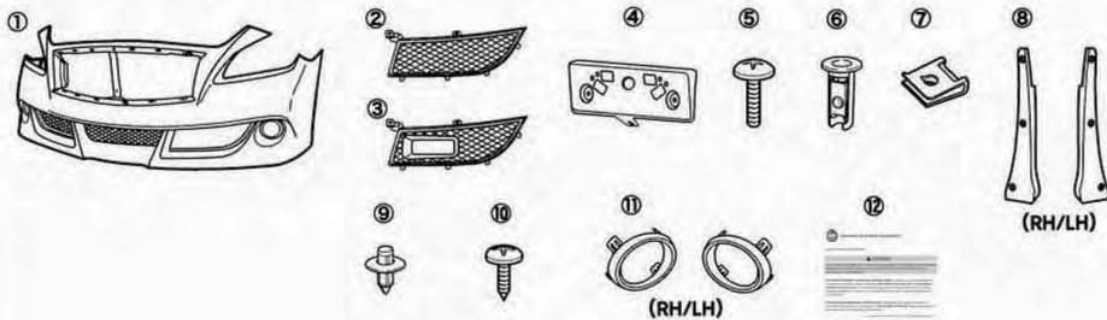

5. TOOLS REQUIRED:

1. Drill
2. Drill Bit (3 mm (1/8"), 6 mm (15/64"), 10 mm (25/64"), 20 mm (3/4"))
3. Box Wrench (10 mm (25/64"))
4. Long-nose Pliers
5. Phillips Head Screwdriver
6. Clip Remover
7. Cutter
8. Awl
9. Scissors
10. Masking Tape
11. Protective Eyewear
12. Nipper

INSTALLATION INSTRUCTIONS - FRONT AERO BUMPER

6. PRE - INSTALLATION NOTE:

- These instructions are for the left side of the vehicle; the same procedure applies to the right side.
- For the right side installation, use the template with the text facing the vehicle.

INSTALLATION INSTRUCTIONS - FRONT AERO BUMPER

7. INSTALLATION PROCEDURE:

1. Preparation for the front bumper removal

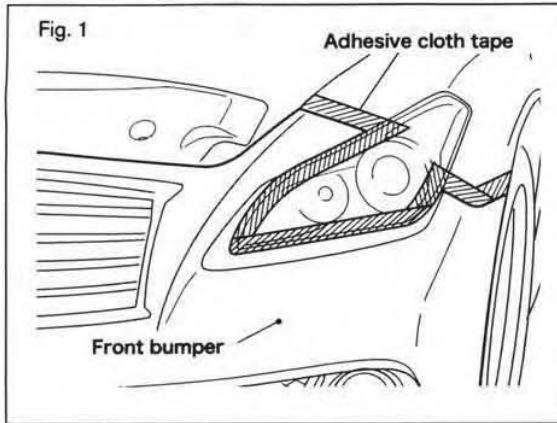

- 1) Open the front hood and remove the battery's negative(-)terminal.
- 2) To prevent scratches, protect the vehicle by applying masking tape. See Fig. 1.

2. Vehicle part removal

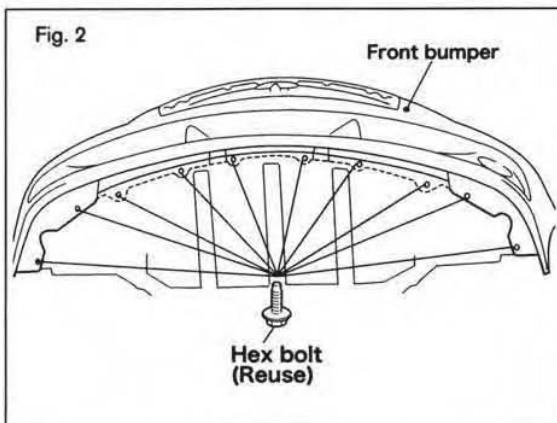

- 1) Remove the hexbolts that hold the Front bumper to the under cover (5 locations on each side). See Fig. 2.

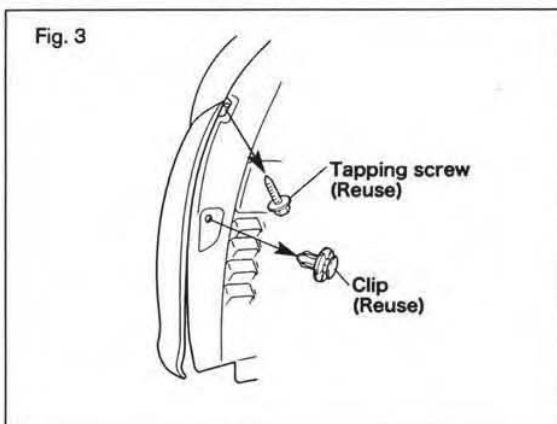

- 2) Remove the clip that holds the fender protector to the fender (1 location on each side) to pull the fender protector. See Fig. 3.
- 3) Remove the tapping screw inside the wheel arch (1 location on each side). See Fig. 3.

NOTE

Be careful not to lose or damage the parts that will be reused.

INSTALLATION INSTRUCTIONS - FRONT AERO BUMPER

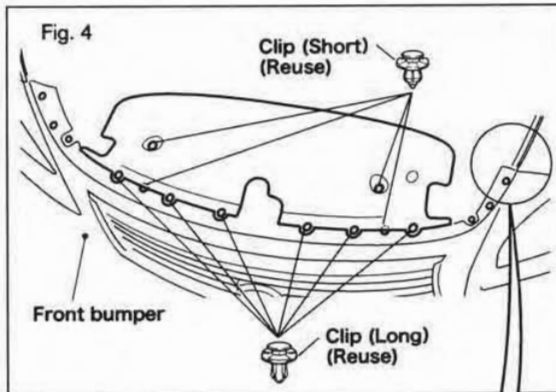

- 4) Remove the clips that mount the upper side of the bumper to the radiator-upper cover (12 locations). See Fig. 4.

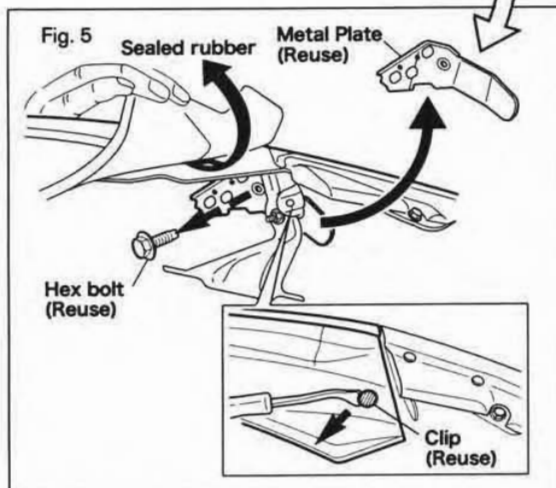

- 5) Remove the hex bolt that seats between the radiator grille and the headlamp to pull the metal plate (hex bolt, 1 location on each side; metal plate, 1 location on each side). See Fig. 5.

NOTE

Be careful not to lose or damage the clips, hex bolts and metal plates that will be reused.

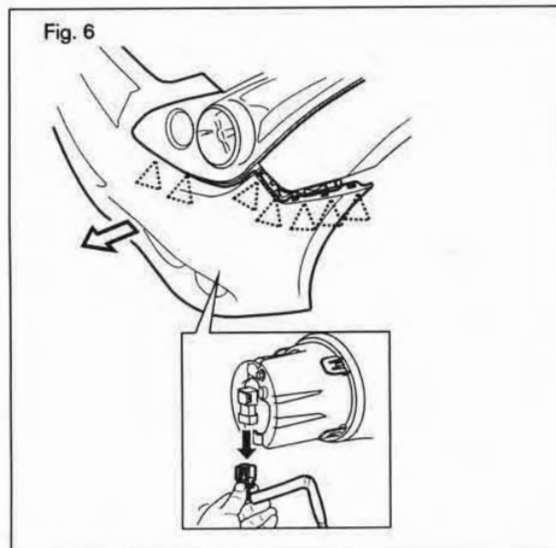

- 6) Pull and detach the front bumper from the claws under the fender and the headlamp (Δ locations on Fig.6). Remove fog lamp connector from the front bumper.

INSTALLATION INSTRUCTIONS - FRONT AERO BUMPER

3. Vehicle part adjustment

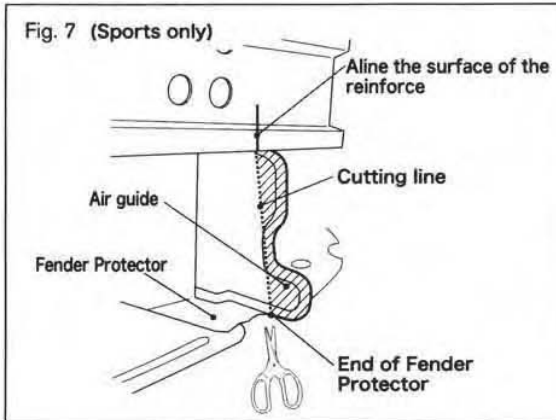

- Cutting the air guide LH (sport only)
- 1) Detach the energy absorber from the reinforcement.
- 2) Position the cutting line by using a masking tape, etc. and cut the front part of the air guide LH along the line by using scissors. See Fig. 7.
- 3) Remove burrs remaining around the cut line.
- 4) Mount the energy absorber back to the reinforcement.

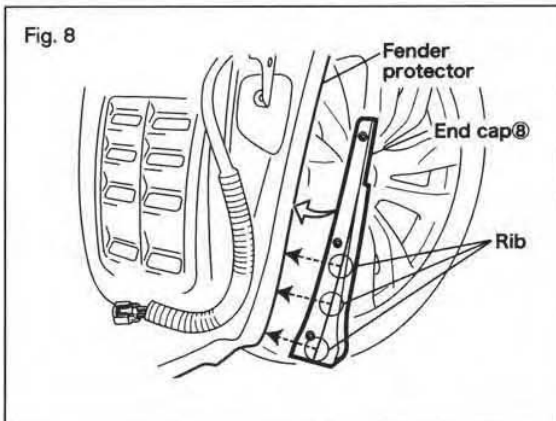

- Install End Cap
- 5) Turn tires
- 6) Temporarily attach the end cap ⑧ by using masking tape in line with the shape of the fender protector. See Fig. 8 and Fig. 9, a-a, b-b.
- 7) Put a marking with an awl at the hole center part of the end cap ⑧ (3 locations on each side). See Fig. 9.
- 8) Remove the End cap ⑧.

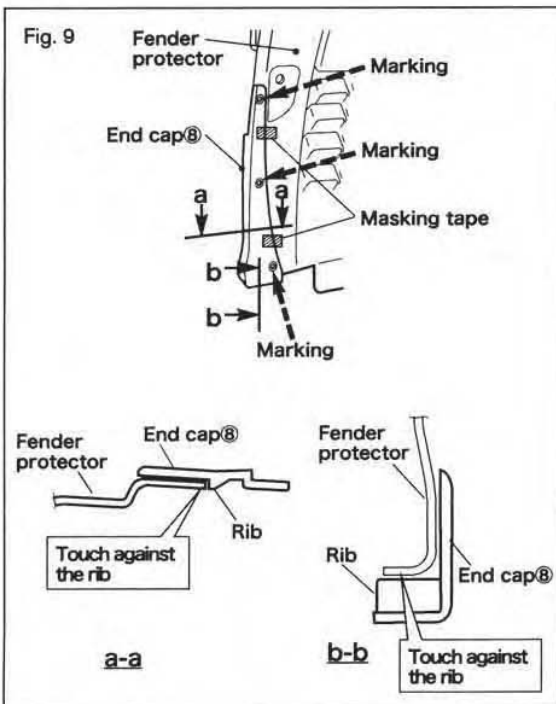

INSTALLATION INSTRUCTIONS - FRONT AERO BUMPER

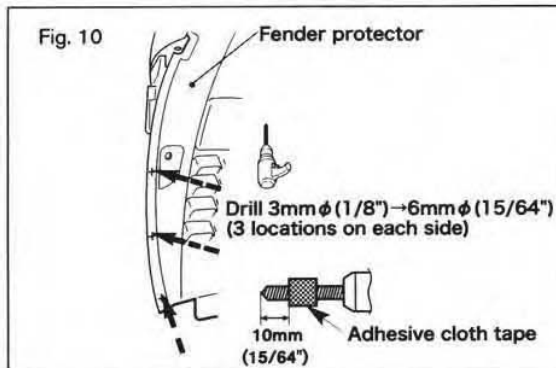

- 9) Drill holes locations marking in step 8) (3 locations on each side; 3 mm ϕ (1/8") pilot holes and 6mm ϕ (15/64") holes). See Fig. 10.
- 10) Remove burrs remaining around the holes.

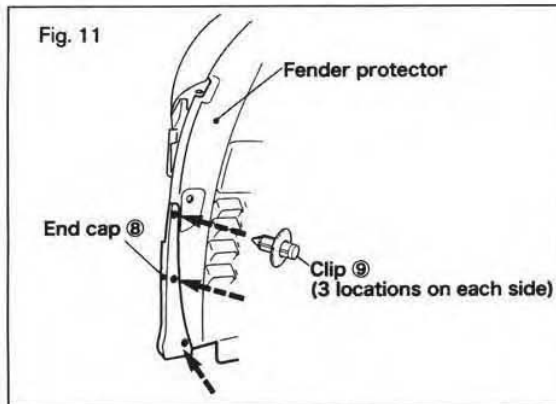

- 11) Mount the end cap LH ⑧ and secure it to the fender protector by using the clips ⑨. See Fig. 11.

4. Front bumper part removal

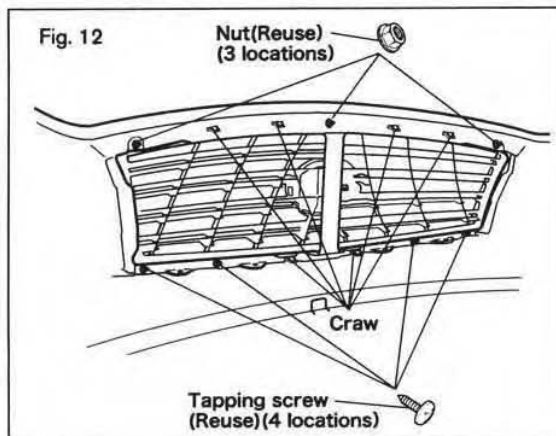

- 1) Remove the nuts and tapping screw on the detached front bumper and detach the radiator grille from the claws. See Fig.12.

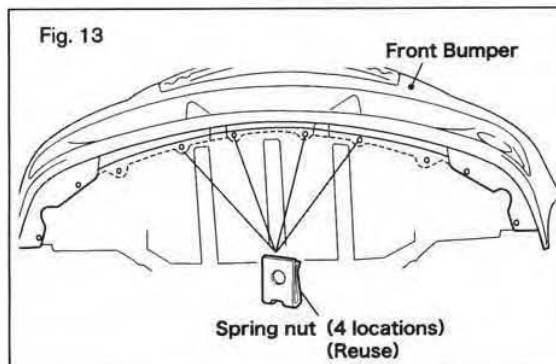

- 2) Remove the spring nuts from the underside of the bumper(4 locations). See Fig.13.

INSTALLATION INSTRUCTIONS - FRONT AERO BUMPER

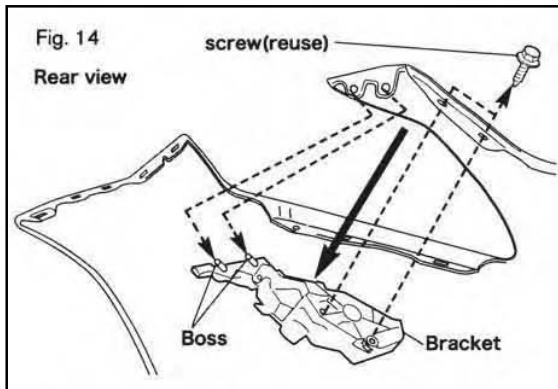

- 3) Disengage the screw on the upper side of the bumper(2 locations)to remove the bracket. See Fig.14.

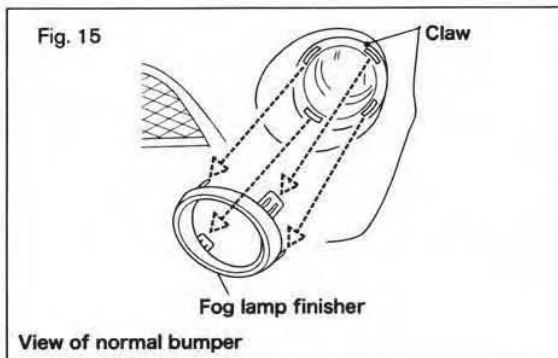

- 4) Detach the claws, and then remove the fog lamp finisher. See Fig.15.

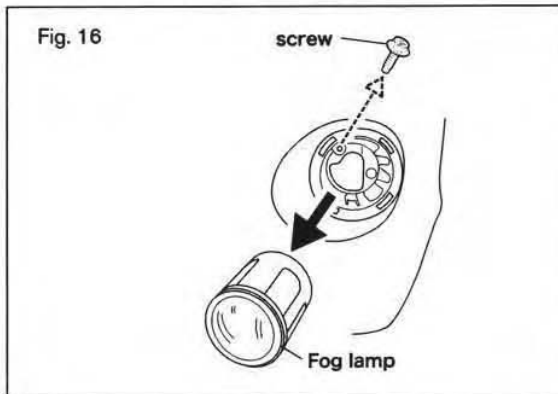

- 5) Remove the hex bolt (1 location on each side), detach the claw, and then remove the fog lamp. See Fig.16.

INSTALLATION INSTRUCTIONS - FRONT AERO BUMPER

5. Preparation for the Front Aero Bumper ① installation

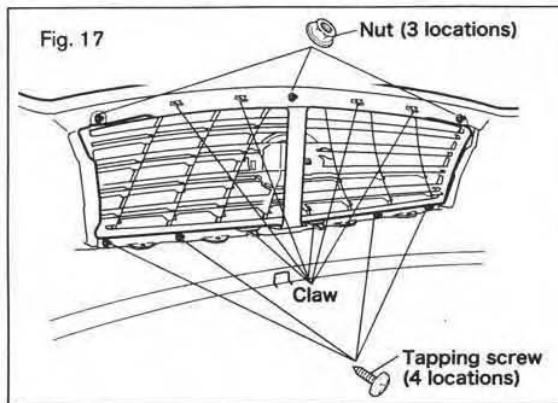

- 1) Reinstall the radiator grille detached in step 4.-1) to the Front Aero Bumper ① with the claws engaged, secure it with the nuts and tapping screw. See Fig.17.

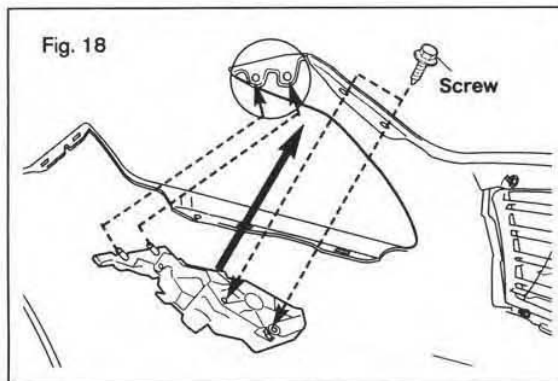

- 2) Reinstall the bracket detached in step 4.-3) to the upper side of the Front Aero Bumper ① by using screw (2 locations on each side). See Fig.18.

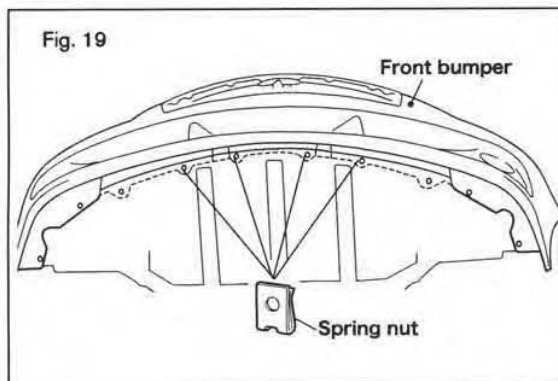

- 3) Reattach the spring nuts detached in step 4.-2) to the under side of the Front Aero Bumper ① (4 locations). See Fig.19.

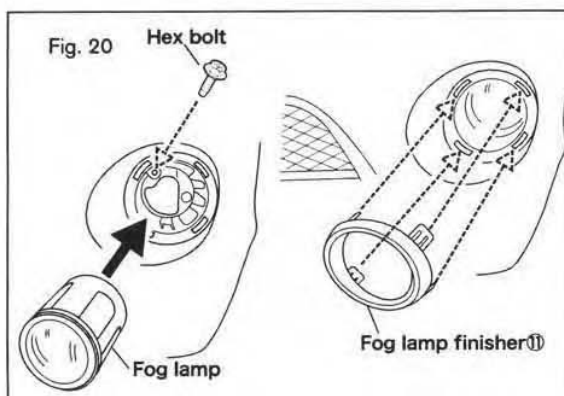

- 4) Reinstall Fog lamp detached in step 4.-5) to the Front Aero Bumper ① with the Hex bolt. See Fig.20.
- 5) Install Fog lamp finisher ⑩ by claw. See Fig.20.