

INSTALLATION INSTRUCTIONS

- 1. DESCRIPTION:** Sports Exhaust System
- 2. APPLICATION:** Q60 Convertible
- 3. PART NUMBER:** B0100-JJ526
- 4. KIT CONTENTS:**

Item	Qty.	Description	Service Part Number
A	1	Main muffler	
B	2	Gasket	20692-1E810
C	1	Installation Instructions Replacement Template	

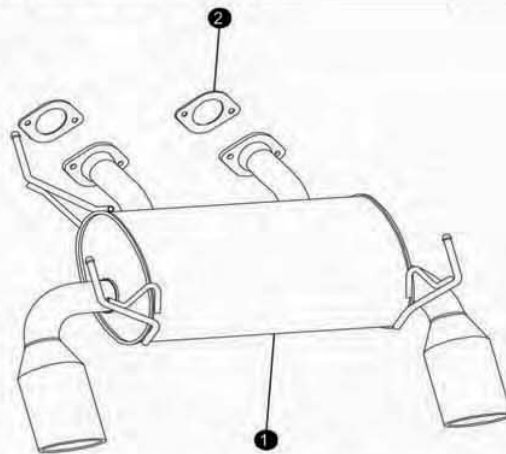

Component parts ① Main muffler ② Gasket x 2

- 5. TOOLS REQUIRED:**
 - Torque wrench
 - Lubricant spray
 - Large, flat tip screwdriver
 - Ratchet wrench
 - Box wrench (14mm)
 - Socket (14mm)

- 6. INSTALLATION PRECAUTIONS AND NOTES:**
 - You will see various symbols in this manual. They are used in the following ways:

⚠ WARNING

- This is used to indicate the presence of a hazard that could cause death or serious personal injury. To avoid or reduce the risk, the procedures must be followed precisely.

⚠ CAUTION

- This is used to indicate the presence of a hazard that could cause minor or moderate personal injury or damage to your vehicle. To avoid or reduce the risk, the procedures must be followed carefully.

INSTALLATION INSTRUCTIONS - Sports Exhaust

A) Before Installation

1. After opening the packing, check to see if any parts are missing and that the product is not damaged.
2. This product should be installed with proper installation tools.
3. Install this product while observing all warnings and precautions stated in this manual.

WARNING

- Do not make any alteration or modification to this product. Serious injury may result.
- After installation, check for clearance and interference with the body and/or chassis parts.
Do not drive the vehicle if interference is found.
Interference could lead to an accident and serious injury.

CAUTION

- Before installation, confirm application and part number. If the product is installed on a different vehicle, it may result in vehicle damage or an accident.
- Allow the vehicle to cool before installation.
- The specified torque shown in this manual must be used. Tightening bolts above the specified torque may result in damage.

NOTE

- Check with your local Department of Motor Vehicles for regulations related to vehicle sound regulations.
- This exhaust has been tested for noise level per SAE J1169 and does not exceed 95 dB(A).

B) Before Using

WARNING

- Read your Vehicle Owner's Manual to assist you in the safe operation of your vehicle. Failure to do so may result in an accident and serious personal injury.
- If any abnormal noises are heard or abnormal vibrations are felt, immediately stop the vehicle in a safe place and check your vehicle.
Driving with an abnormal condition may result in an accident and serious personal injury.
- Do not use the product for anything other than the purpose described in this manual. Any accident or injury incurred by improper use of this product is the sole responsibility of the user.

NOTE

- The minimum distance between the ground and the bottom of the vehicle becomes less due to the installation of the product.
- When driving over bumps or unpaved or rough roads, lower speed may be necessary to avoid damage from contact between the road and the vehicle's body.

INSTALLATION INSTRUCTIONS - Sports Exhaust

7. INSTALLATION PROCEDURE:

A) Removal

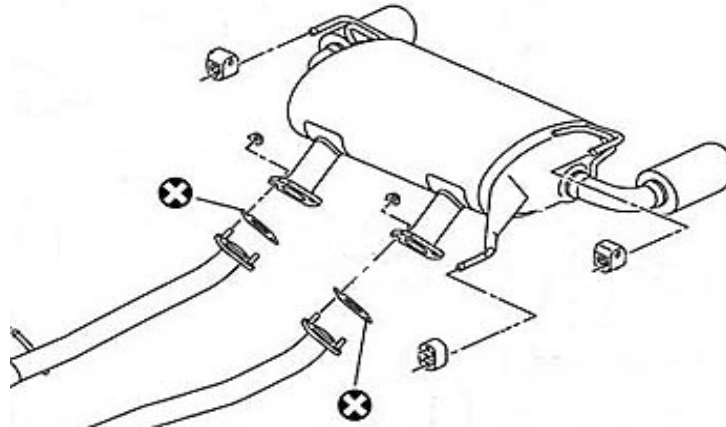

First remove the nuts of the part to be replaced and mounting rubber, and then remove the genuine exhaust system from the vehicle body.

CAUTION

- Care should be taken to prevent any damage to propeller shaft.
If needed use necessary protection to prevent damage.

NOTE

- Cannot reuse (metal gaskets) as shown in the figure marked "X" to the part on the figure.
- All rubber mount will be reused for SPORTS EXHAUST.
- All other parts which are removed in the figure do not have to be reused.
 - Care should be taken when removing and installing parts around propeller shaft.

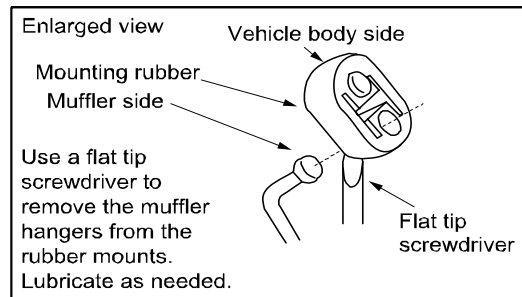

INSTALLATION INSTRUCTIONS - Sports Exhaust

B) Installation

Installation in the reverse order of removal.
Use lubrication on rubber mounts as needed.

CAUTION

- Before installation, remove deposits from each connection portion.
- Replace all the gaskets with new ones. (Use included gaskets.)
- If the heat insulator on the vehicle is badly deformed, repair or replace it.
- Make sure during installation there is clearance at the brake piping and the propeller shaft.
- Temporarily tighten each installation nut, and after confirming that there is a proper alignment of the system, then tighten them to the specified torque.
- Install so that the main muffler is as horizontal as possible when viewed from the rear of the vehicle.

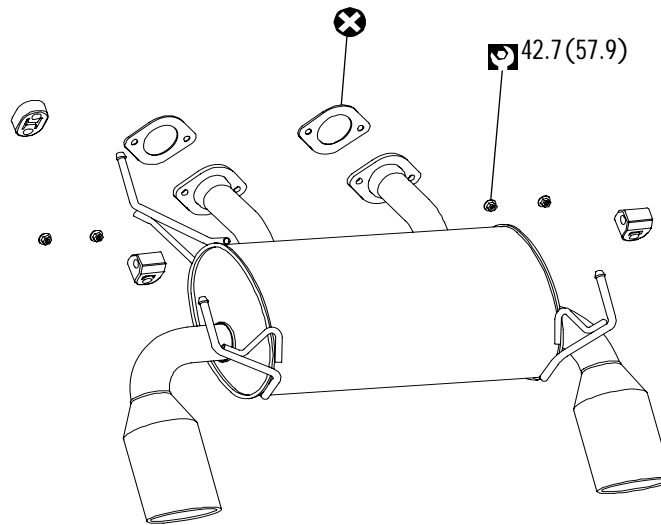

- ⊗ : Un-reusable parts
- Ⓜ : ft-lbf (N-m)

NOTE

- When installing SPORTS EXHAUST use new gaskets which are provided in the kit (Parts No.: 20692-1E810).

INSTALLATION INSTRUCTIONS - Sports Exhaust

CAUTION

- If the space between tips and rear bumper is narrow, please alignment of the system to gain needed clearance 0.78 inch.
- It might cause the allophone by contact and the heating of the bumper, etc. when clearance shortage is left, and a serious breakdown occur.

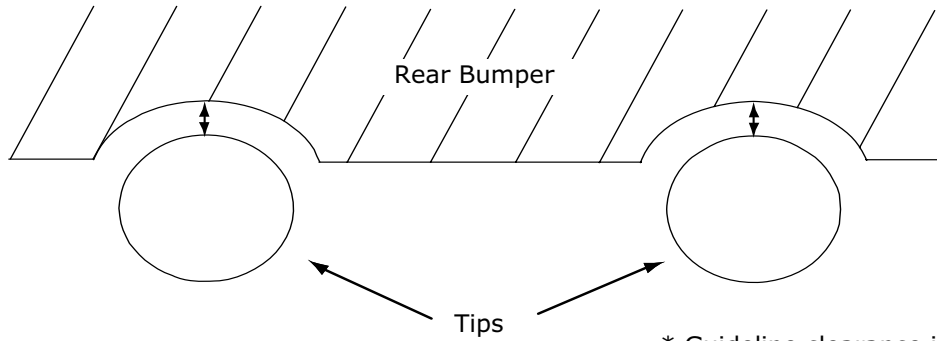

Check after installation is complete

1. After installation please check the clearances around piping, flanges, brackets, hangers, resonator/silencer, muffler, tip, etc... This can be done by using your hands to push, pull, shake, or jiggle the exhaust system. The rubber hangers or hardware should allow some movement of the exhaust system. (Note: be sure to thoroughly wipe the entire exhaust system before starting the engine, as any oils or dirt will discolor the exhaust components.)
2. Make sure that rubber mounts are not excessively stretched or twisted.
3. Start and warm up the engine. Then rev the engine to 2500-3000rpm and hold. Check to make sure there are no exhaust leaks, or unusual noises.
4. Test-drive the vehicle and re-check for any exhaust leaks, and/or any unusual noises.
5. If anything unusual occurs in steps 1, 2, and/or 3, return to the installation process. Make sure all gaskets are in place, and hardware is fastened to specified torque settings.