



INFINITI.

GENUINE PARTS

INSTALLATION INSTRUCTIONS

DESCRIPTION:	Wireless Charging Kit
APPLICATION:	Infiniti QX60
PART NUMBER(S)	999F7 V4300
REQUIRED FOR INSTALLATION:	999Q9-AY001/T99F6 4RA0A (Accessory Service Connector) - Not Included in kit.
KIT CONTENTS:	

Item	Qty.	Part Description	Service Part Number
A	1	Wireless Charging Module	999F7 V4006
B	1	Harness Assembly	999F7 V4002
C	8	Wire Ties	
D	11	Foam Tape	
E	2	Posi-Taps	999M1 VT000
F	1	Double Sided Tape	
G	1	Drilling Template	T98F7 6SA0A
H	1	Owners Manual/Quick reference	999F7 V3010
I	1	Poly Bag	
J	1	Installation Instruction Replacement Template	999V2 AW000

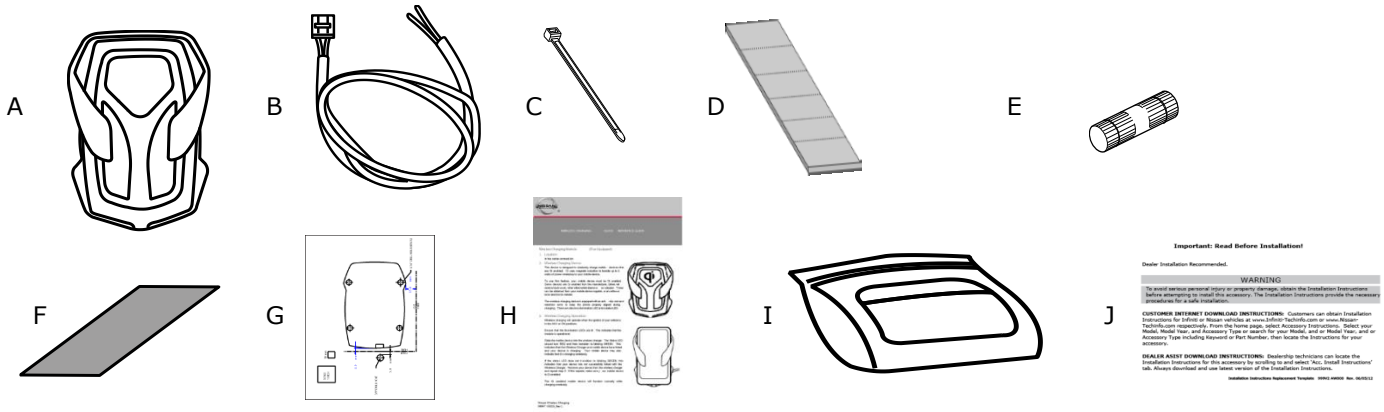

Important: Read Before Installation!
 Dealer Installation Recommended.
WARNING
 The use of any power tool or other device, other than the Installation Instructions, before attempting to install this unit is prohibited. The Installation Instructions provide the necessary instructions for a safe installation.
CUSTOMER DOESN'T DOWNLOAD INSTRUCTIONS: Customers can obtain Installation Instructions for 2016 or newer vehicles at www.infiniti.com or select Retailer. Technicians can request them from the Home page, select Accessory Instructions. Select your Model, Model Year, and Accessory Type or search for your Model, year or Model Year, and an Accessory Type including Keyword or Part Number, then locate the Instructions for your Accessory.
DEALER ASSET DOWNLOAD INSTRUCTIONS: Dealership technicians can locate the Installation Instructions for this accessory by logging on and select "New Install Instructions".
 All Rights Reserved and use under license of Infiniti. ©2015 Infiniti. All rights reserved.
 Infiniti Service Representative Training: 9883-0000 Rev. 08/2015

999Q9 AY001 (ACCESSORY SERVICE CONNECTOR) - SERVICE PART

Item	Qty.	Part Description	Service Part Number
AA	1	Accessory Service Connector (NOT INCLUDED IN KIT)	999Q9-AY001/T99F6 4RA0A



Note: 1 or 2 Accessory Service Connectors may already be installed in the vehicle.

TOOLS REQUIRED:

- Air-Right Angle Drill
- 7/16" Drill Bit
- 1/16" Drill Bit
- Step Drill Bit
- 12mm Wrench
- Trim Removal Tool
- Round File
- Fishing Tape
- Alcohol Wipes

Vehicle Preparation:

⚠ CAUTION

• Always confirm the ignition is in the "OFF" position before changing the switch condition.

- 1) Apply parking brake
- 2) Confirm vehicle is not in the default shipping state or "Inventory position" as shown below. Failure to confirm vehicle has been removed from this state will result in loss of normal vehicle operation.
- 3) Locate Extended Storage Switch in cabin fuse block. Confirm it is in the "Customer" position. See below for reference.

- a) To remove transit mode (Fuse Block):
1. Remove fuse cover lid.
 2. Push down shorting pin.
 3. Ign On 2 times without starting the vehicle.

- b) To remove transit mode (BCM):
1. Confirm ignition switch is in "OFF" position.
 2. Simultaneously push the signal and wiper switch fully down for two (2) seconds.

NOTE: While in BCM Transit Mode, turn signal indicators will remain illuminated for one minute.

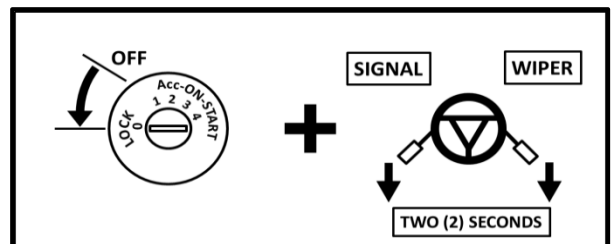
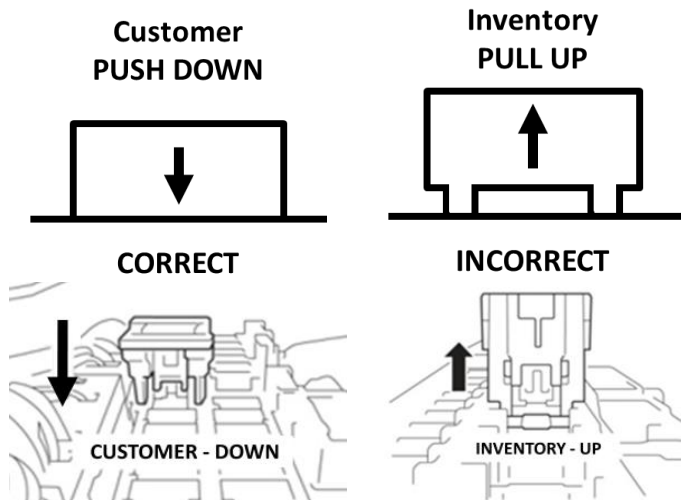

- c) To return to transit mode for storage:
1. Ign Off.
 2. Remove fuse cover lid.
 3. Pull up shorting pin.
 4. Assemble fuse cover lid.
 5. Ign On 2 times without turn the vehicle on.
 6. Confirm transit mode condition on meter

NOTE: Typical vehicle condition shown above. Switch is easily identifiable by the permanent, push-pull fuse holder. Actual position on the fuse block may vary, vehicle to vehicle.

Condition	Switch Position	Note
Vehicle is delivered to the dealer	Inventory Condition	
Technician performs PDI	Customer Delivery	Return to Inventory position after PDI.
Customer test drives the vehicle	Customer Delivery	Return to Inventory position after test drive.
Vehicle is being stored at the dealer	Inventory Condition	
Vehicle is delivered to customer	Customer Delivery	

NOTE: The Extended Storage Switch is only an aid to improve battery life during vehicle storage at the dealer. If the Extended Storage Switch fuse ever needs service after vehicle delivery, discard the Extended Storage Switch and install the correct fuse in its place.

- 4) Turn ignition switch to "ON" position
- 5) Record the customer radio presets and other presets as required.

Preset	1	2	3	4	5	6	

- 6) Put shift lever in "P" position for A/T and CVT or "1st" for M/T
- 7) Turn ignition switch to "OFF" position
- 8) Use seat and floor protection.

8. INSTALLATION OVERVIEW:

1.) SYSTEM

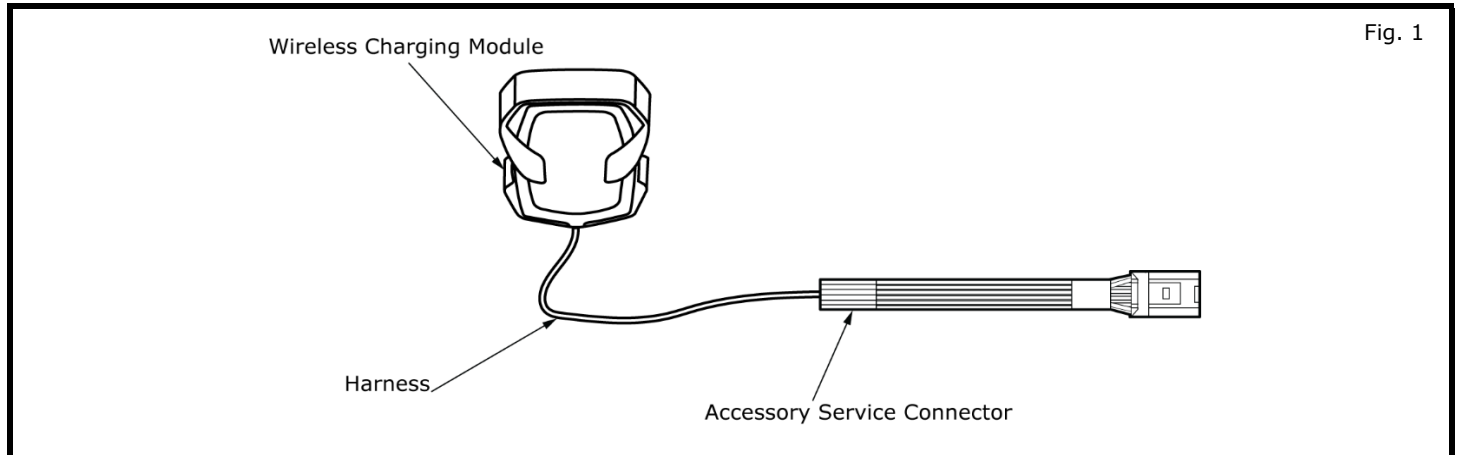

2a.) VEHICLE

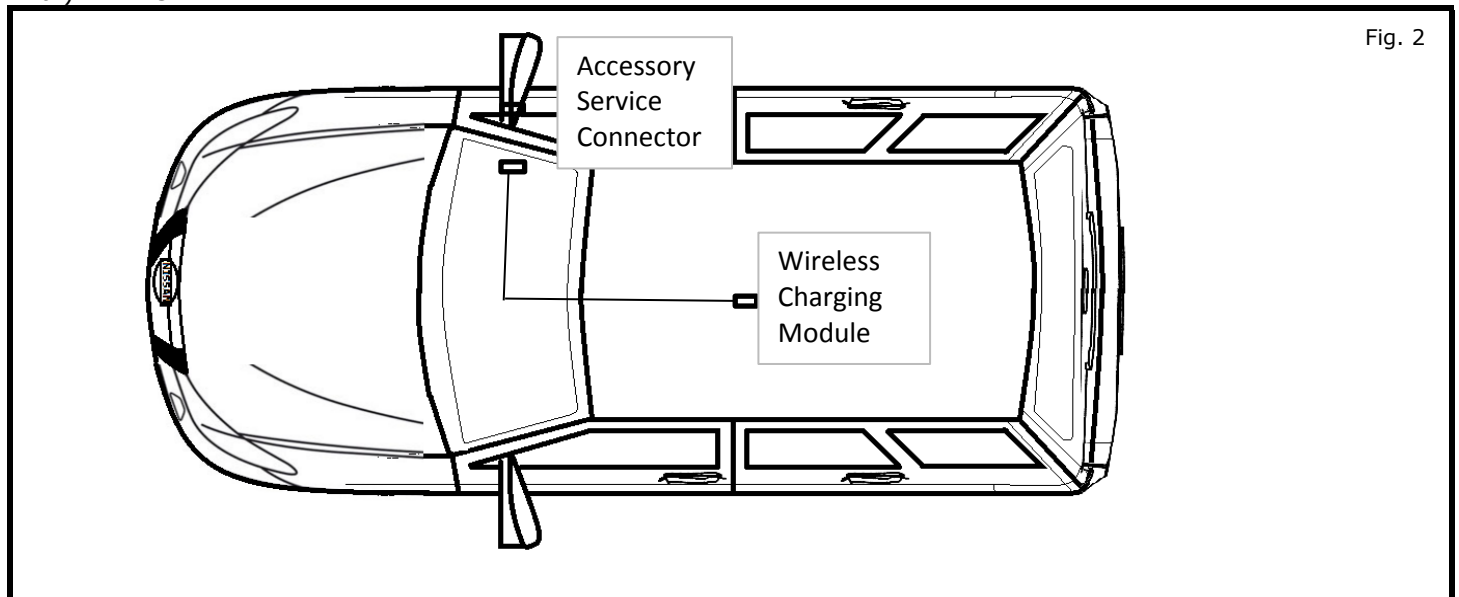

PRE-INSTALLATION CAUTION/NOTES

- Dealer installation recommended. Instructions may refer to Service Manual
- Installation may require special tools
- This part is to be installed within a surface temperature range of 65-100°F

⚠ CAUTION

- This accessory must only be installed as specified in these instructions.
- Ensure at all times that parts are securely fitted and will not compromise the safe function of vehicle systems
- Take care not to scratch or damage any component during the removal or re-installation process.
- Always remove vehicle parts in the sequence they are shown, improper procedure can damage parts.
- Store removed parts in a safe and protected manner.
- Place module in vehicle as described to ensure that the vehicle I_Key system works properly

PRE-INSTALLATION CAUTION/NOTES

- Dealer installation recommended. Instructions may refer to Service Manual
- Installation may require special tools
- This part is to be installed within a surface temperature range of 65-100°F

⚠ CAUTION

- This accessory must only be installed as specified in these instructions.
- Ensure at all times that parts are securely fitted and will not compromise the safe function of vehicle systems

2b) Remove the following vehicle parts in the sequence shown below. Store these re-usable parts in a safe and protected manner.

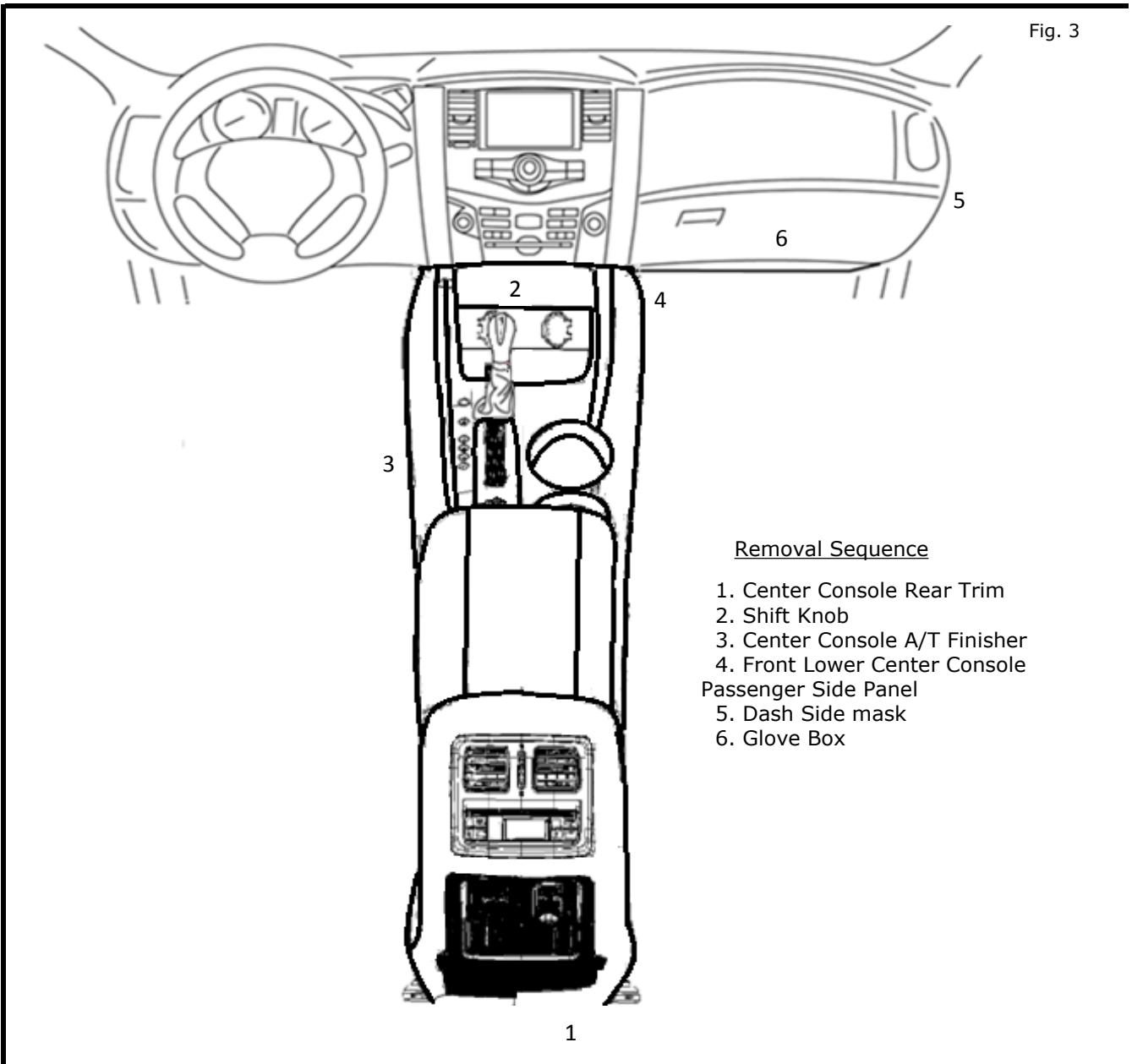

INSTALLATION PROCEDURE:

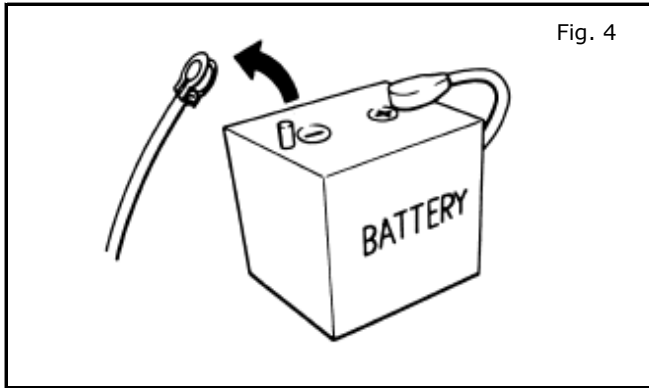

- 3) Turn ignition switch to "OFF" position

Disconnect negative battery terminal.

- a) Lower both driver and passenger windows to prevent damage.
- b) Disconnect negative battery terminal.

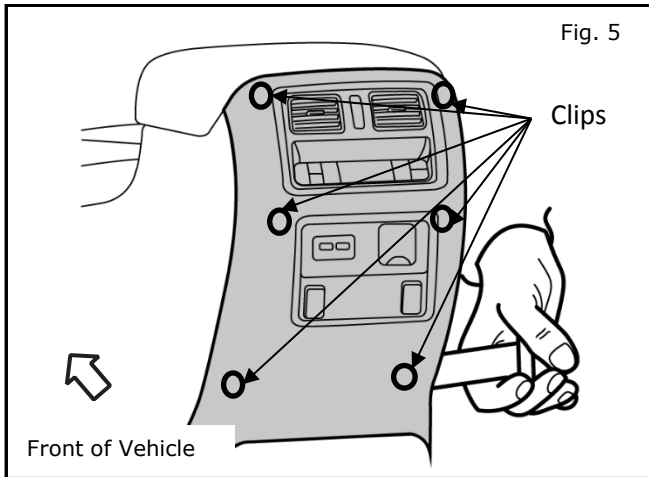

- 4) Removal of Center Console Rear Finisher.

- a) Starting from bottom of console using trim removal tool, remove console at six clip locations. See Figure 5

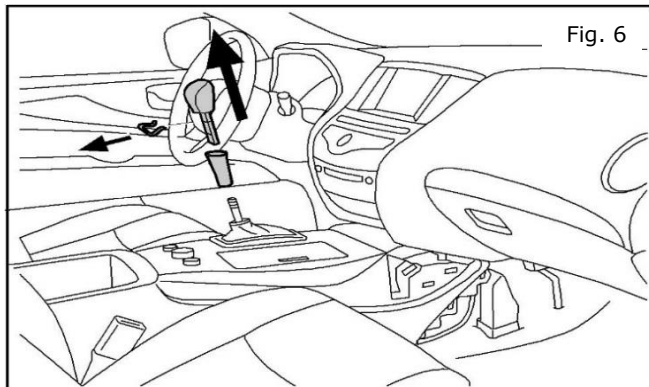

- 5) Shift knob removal.

- a) Pull down lower cover of shifter knob.
- b) Remove shift knob retaining clip and pull knob off of shaft.
- c) Replace clip on shift knob and set knob aside.

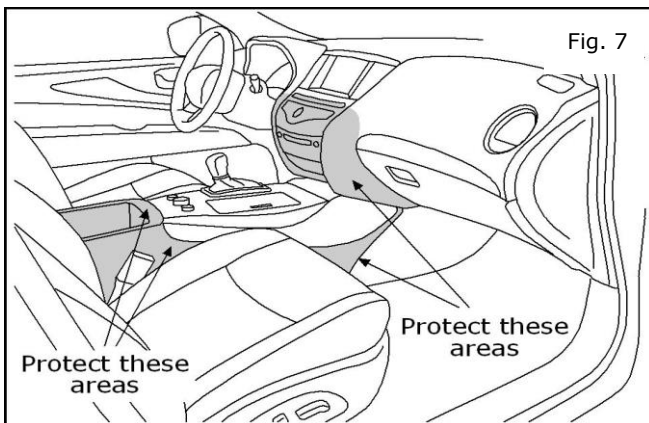

- 6) Place masking tape on indicated edges for protection during installation.

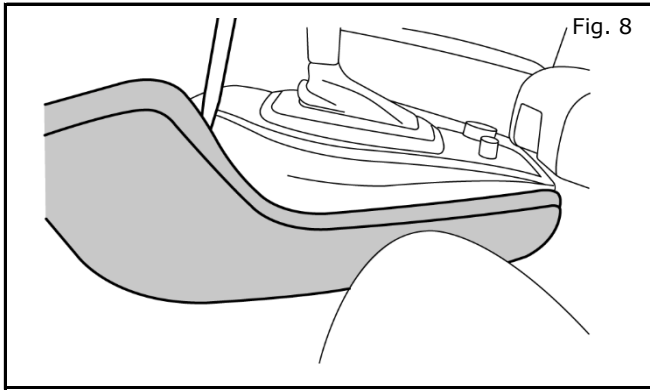

- 7) Remove Side Trim Panels
- a) Carefully remove LH AND RH Side trim panels using trim removal tool.

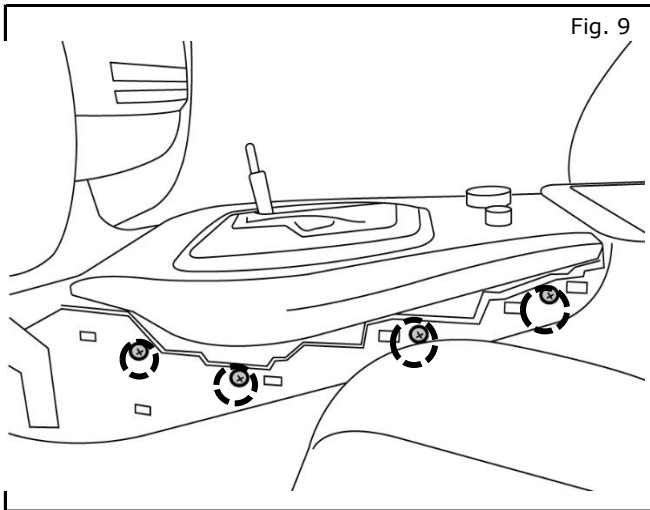

- 8) Remove Screws Holding A/T Finisher.
- a) Remove 4 screws shown on both the left AND right hand side of A/T finisher using screw driver.

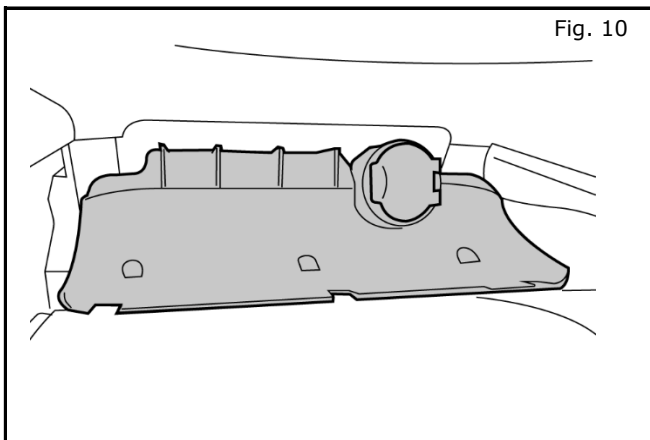

- 9) Remove forward trim piece.
- a) Remove anti-slip liner covering forward A/T finisher.
 - b) Once anti-slip liner is removed, pry off forward A/T finisher using trim removal tool.
 - c) With the tray lifted up, locate the two (2) phillips head screws on each side of the center stack. Loosen these screws enough to remove the two center console trim panels. DO NOT fully remove the screws.

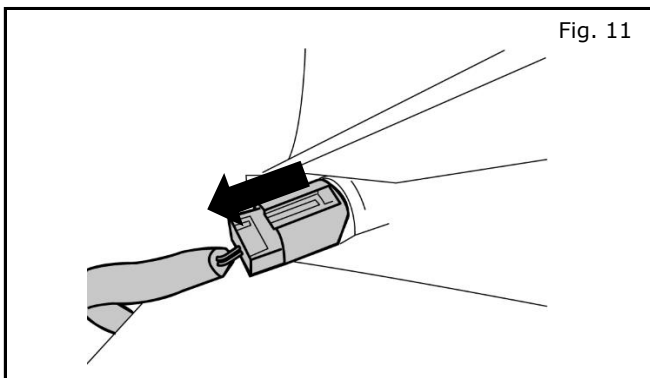

- d) Once trim piece is removed, disconnect harness attached to cigarette lighter and place trim piece aside.

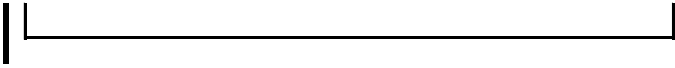

INSTALLATION PROCEDURE:

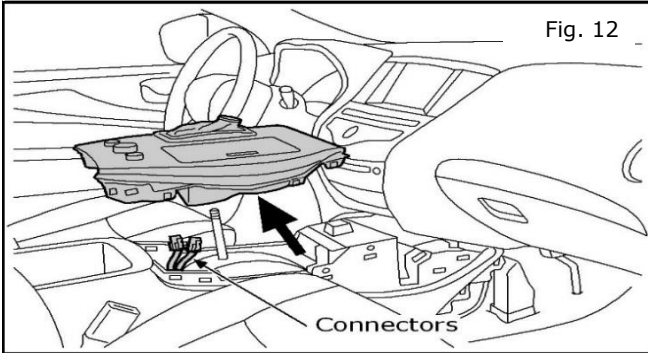

- 10) Carefully pry out shifter trim panel from center stack. Disconnect all electrical connections and set trim panel aside.

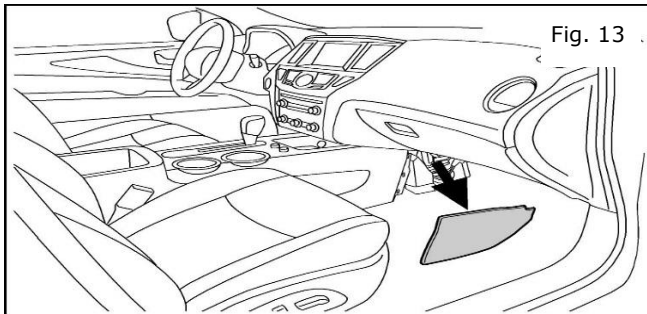

- 11) Remove passenger side console kick panel.
 - a) Carefully pry out center footwell panel from passenger side of center console.
 - b) Pull out at center and slide to rear.

NOTE:
Ensure front retainer clip stays with panel.

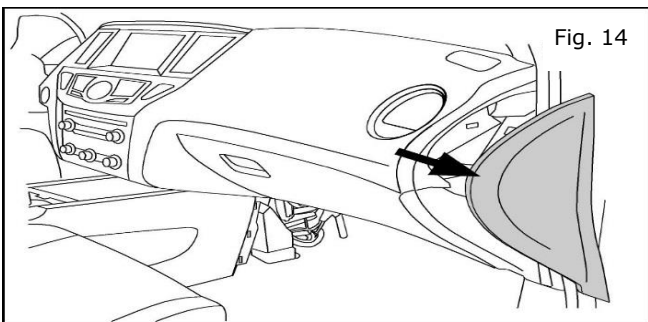

- 12) Carefully pry off passenger side dash side mask.

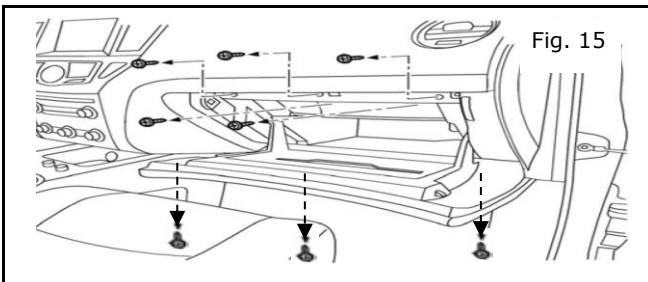

- 13) Using philips screw driver, remove glove box screws as shown in Fig 15.

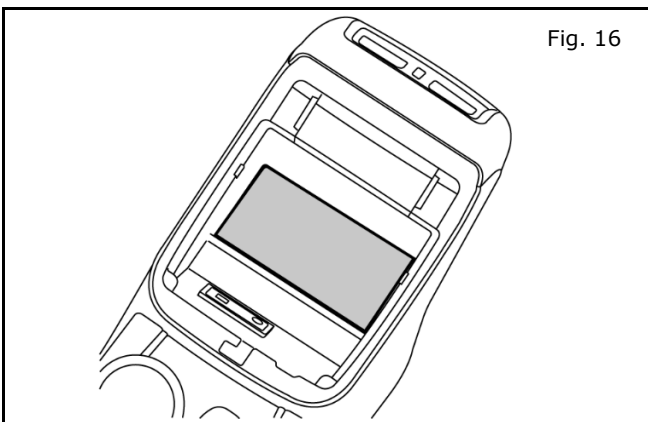

- 14) Remove carpet from bottom of armrest bin and set aside.

INSTALLATION PROCEDURE:

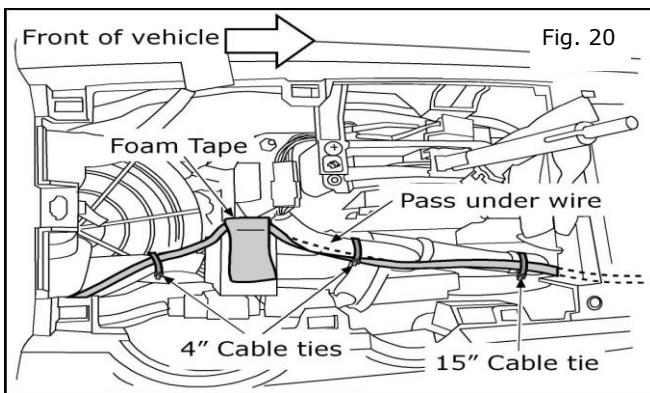
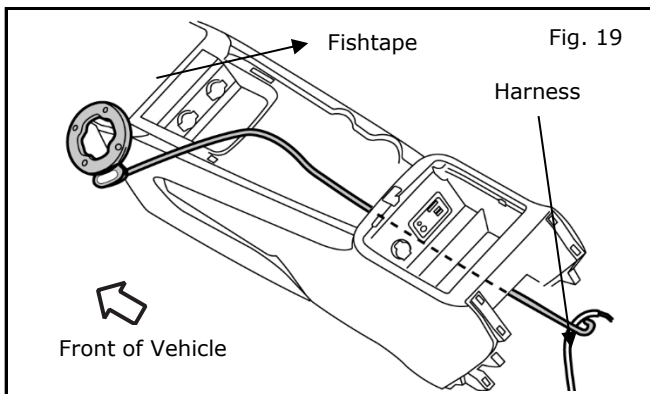
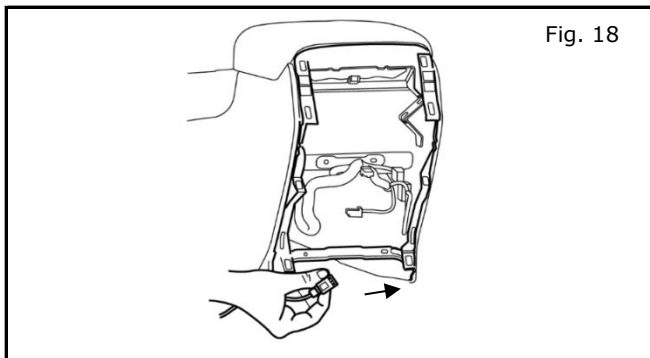
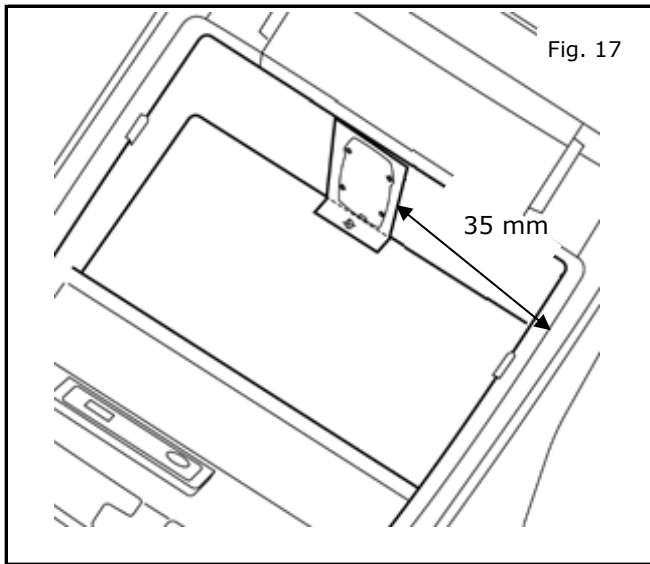

Locate Wireless Charging module as shown in this instruction. Failure to do so may impact operation of iKey system, and prevent vehicle from starting. Make sure edge of template is at 35 mm from the edge of inside bin.

- 15) Drill holes in console box.
 - a) Securely attach supplied templates to bottom and passenger inside of bin with tape.
 - b) Using center punch, locate center of hole drilling locations. One hole located on bottom of bin and four located on side of bin. See Figure 17.
 - c) Using pneumatic (air) drill and 7/16" bit, drill hole on bottom of bin.
 - d) Using 1/8" bit, drill pilot holes on side of bin. Use step drill to finish holes to 7/16".
 - e) Dry fit part to confirm fit.
 - f) Clean debris from bin.

- 16) Route harness connector end into bin through 7/16" hole drilled above from rear of center console.

Once connector is seen inside bin, connect wireless charging module (listen for the "click" to confirm connection).

- 17) Route fish tape through center console towards rear of center console.
 - a) Secure remaining harness to fish tape.
 - b) Carefully pull harness using fish tape.

- 18) Use two cable ties to secure the accessory harness to existing harnesses in vehicle. Do not tighten until instructed.
Continue routing harness towards front of vehicle as shown.

INSTALLATION PROCEDURE:

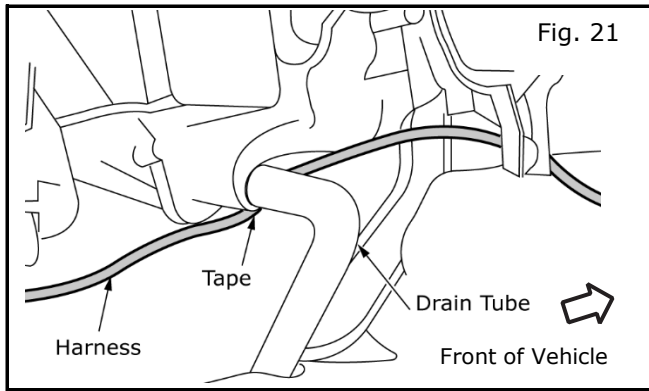

- 19) Route harness to inside of drain tube. Tape as indicated.

NOTE:

Do Not Disturb Drain Tube

Do Not Apply Wire Tie to Drain Tube

Ensure Harness Routes Behind Drain Tube

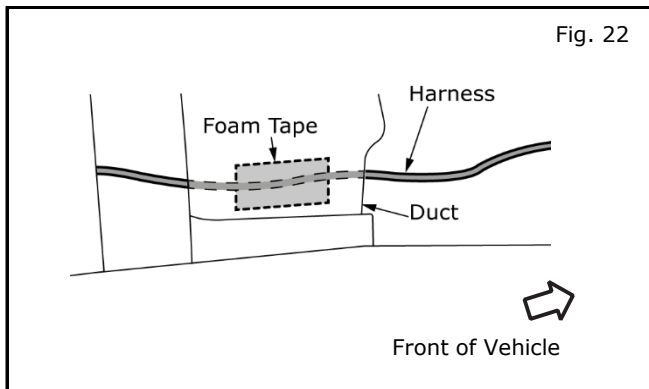

- 20) Use one piece of foam tape to mount harness to duct.

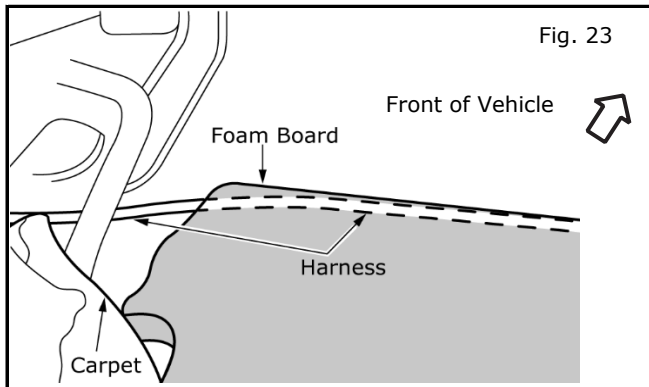

- 21) Pull back carpet and route harness to accessory service connector. Tuck harness under foam board as shown.

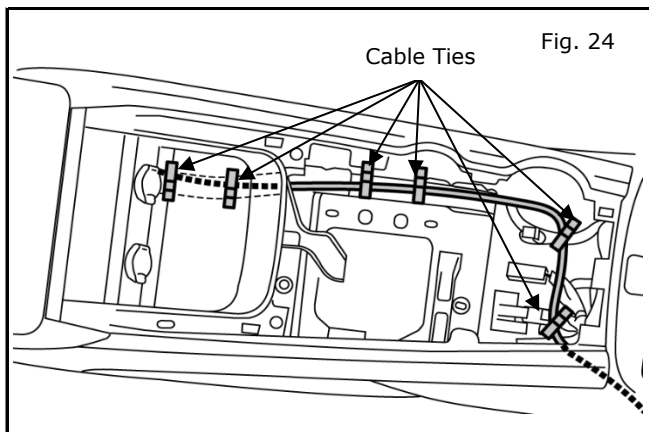

- 22) Secure harness to existing harness using cable ties. Do not tighten the cable ties until instructed.

A total of 6 cable ties will be used in center console area

INSTALLATION PROCEDURE:

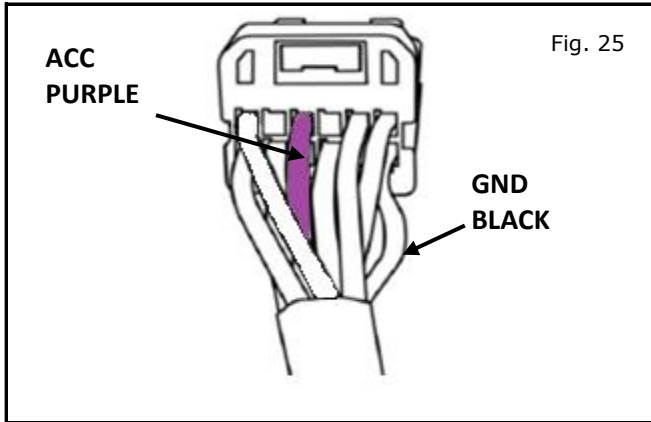

- 23) Tap accessory harness to service connector.
 Posi-tap GND and ACC.
- Tap **Black** accessory harness wire to **Black** service connector wire.
 - Tap **Red** accessory harness wire to **Purple** service connector wire.

NOTE:

- Proceed to pages 11 through 13 for direction on how to posi-tap.
- For additional circuit information, refer to mech drawing at end of installation instructions.

CAUTION

This Accessory Service Connector is for use only with Genuine Nissan (or Infiniti) or Nissan (or Infiniti) approved accessories. Use of this connector with non Genuine Nissan (or Infiniti) or Nissan (or Infiniti) approved accessories or failure to follow the installation instructions for the connector contained in this package may result in damage to the accessory and/or your vehicle. Nissan (or Infiniti) is not liable for loss or damage due to improper installation or the installation of non Genuine or non approved

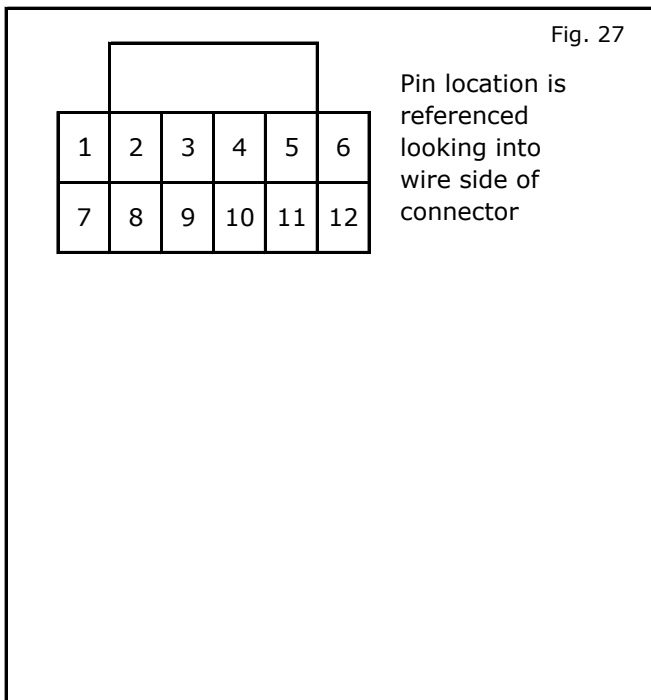
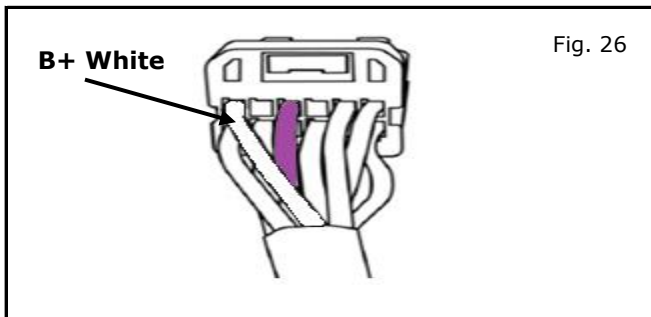

INSTALLATION PROCEDURE: POSI-TAP

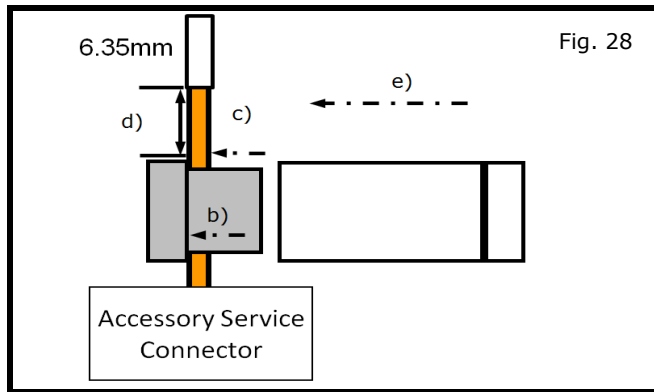

- 24) Posi-tapping an Accessory service wire (Fig. 28)
- Identify and confirm correct wire in the Accessory Service Connector to be tapped.
 - Remove cap (slot side) from tap body.
 - Slide cap around single accessory wire.
 - Position cap $\geq 6.35\text{mm}(0.25\text{in})$ away from the heat shrink end of Accessory Service Connector (measurement for first posi-tap installed on the circuit).
 - Tighten the tap **TIGHT** with finger pressure.
 - Tighten by another quarter turn.

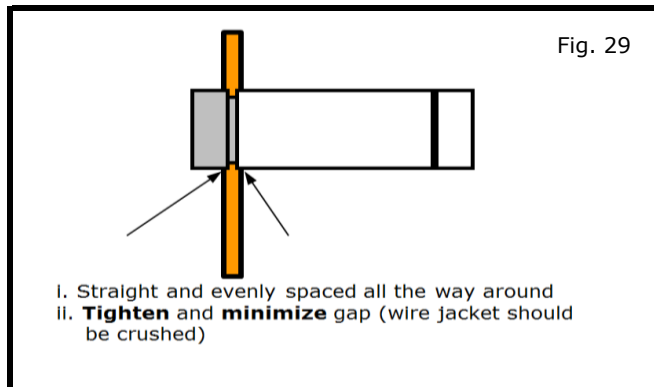

- 25) Inspecting the tap for correct installation (Fig. 29).
- Pull on the wire lightly to ensure connection.
 - Inspect the tap to ensure correct installation.
 - Test the signal to ensure that it is working

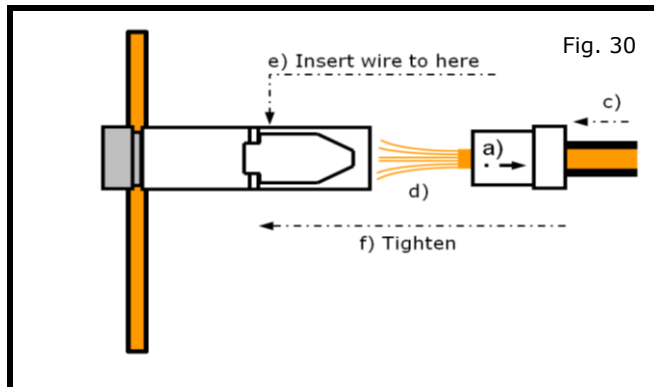

- 26) Tap accessory wire (Fig. 30).
- Remove tap (non-pierce) side from tap.
 - Remove the protective stub from the wire.
 - Insert wire through the non-pierce side opening.
 - Spread the individual strands into fan shape.
 - Insert wire into the tap body and ensure that it is all the way in.
 - Tighten the tap **TIGHT** with finger pressure.
 - Tighten by another quarter turn.

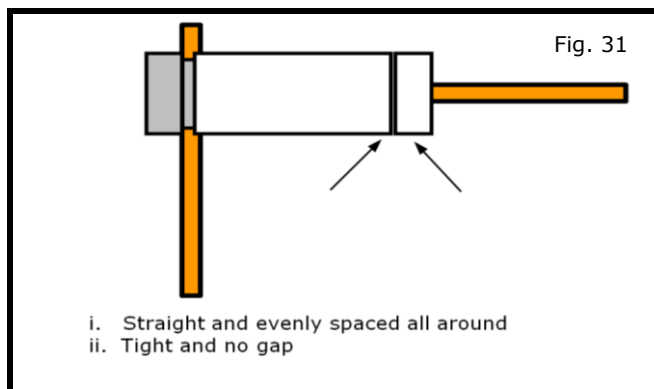

- 27) Confirm the tapped accessory wire.
- Pull on the wire lightly to ensure connection.
 - Inspect the tap to ensure correct installation as shown in Fig. 31.

INSTALLATION PROCEDURE: POSI-TAP

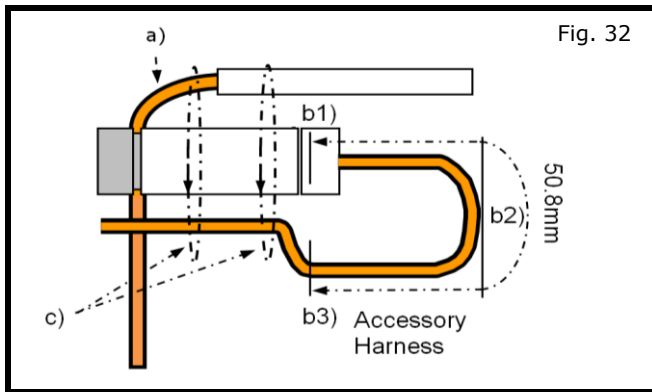

- 28) Forming strain relief loop - required (Fig. 32).
- Gently bend end of pierced wire (where it exits cap) down towards body of posi-tap.
 - On tapped side wire; starting at point b1), measure 50mm to point b3). Make first bend of loop b2), half measured distance - 25mm, and up toward body of posi-tap, make second bend of loop b3).
 - Secure pierced wire on heat shrink side and tapped wire to body of tap with electrical tape (≥ 2 revolutions).

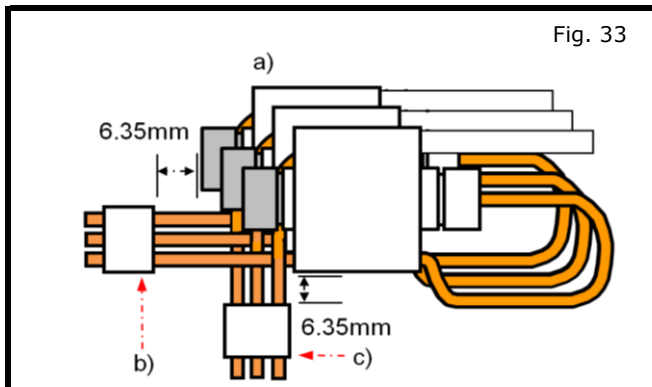

- 29) Securing multiple accessory taps (Fig. 3..).
- Tapped accessories (wires already secured to tap bodies) are stacked in a stagger on top of each other as shown in Fig a).
 - Secure tapped wires on connector side of posi-taps to each other with electrical tape (≥ 2 revolutions) at a distance of ≥ 6.35 mm as shown in Fig b).
 - Pierced wires of posi-taps are secured to each other with electrical tape (≥ 2 revolutions) at a distance of ≥ 6.35 mm (0.25in) as shown in Fig c).

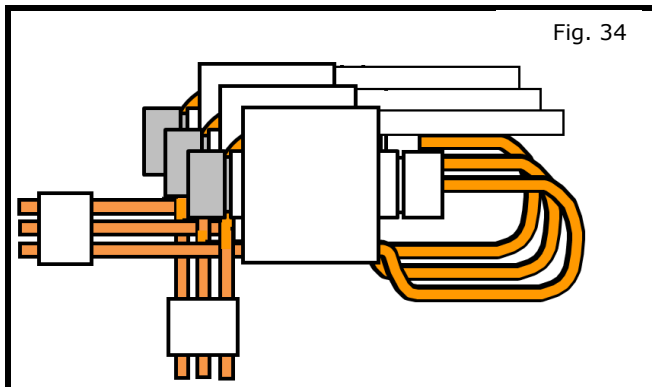

- 30) Securing multiple accessory taps (Fig. 34).
- Make sure the accessory taps have been wrapped appropriately as detailed previously and as shown.

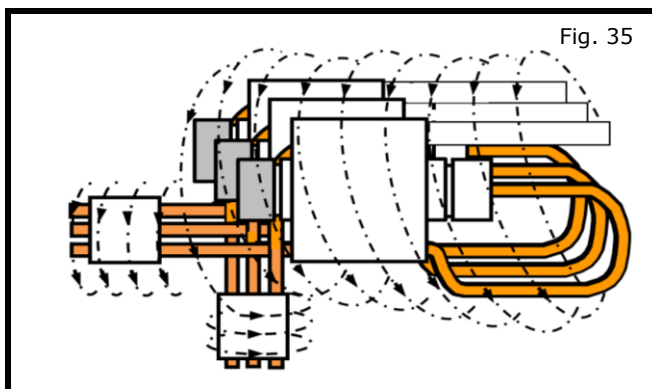

- 31) Securing multiple accessory taps.
- Starting at heat shrink; firmly wrap posi-tap bundle with electrical tape or non-adhesive wire harness tape, making sure to overlap previous revolution.
- Note:** If using non adhesive tape secure at the of wrap with electrical tape ≥ 2 revolutions.

INSTALLATION PROCEDURE: POSI-TAP

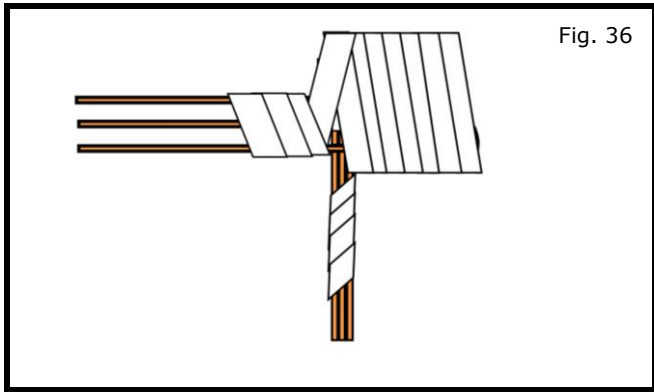

- 32) Securing multiple accessory taps
a) Make sure the finished wrap looks similar to Fig. 36.

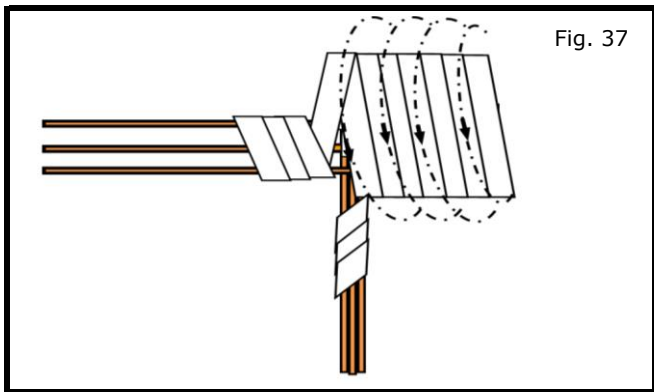

- 33) Foam wrap for posi-tap bundle (foam strips)
a) Wrap the posi-tap bundle with foam tape, following a pattern similar to the electrical tape, making the best use of foam strips provided.

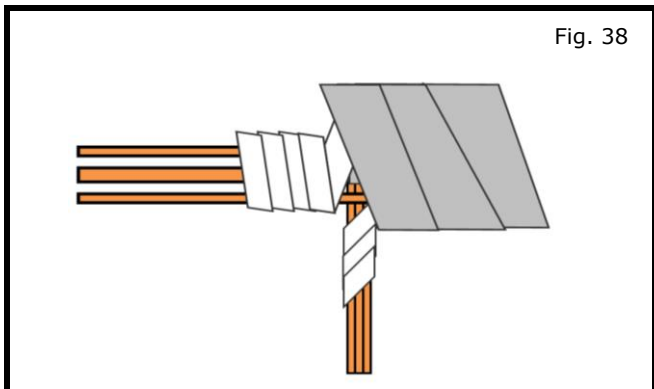

- 34) Finished foam wrap for bundle (strips-top view)
a) Make sure the finished wrap looks similar to Fig. 38.

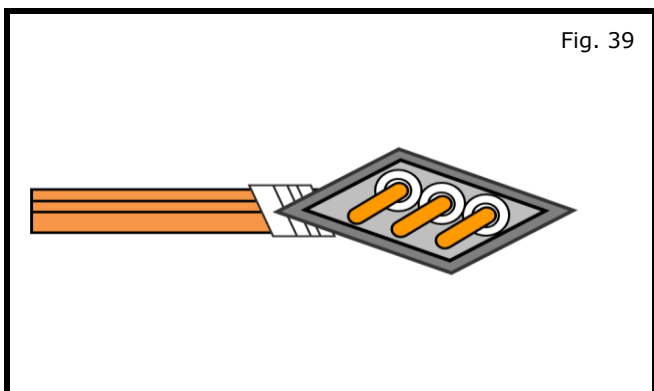

- 35) Finished foam wrap for bundle (strips-side view)
a) Make sure the finished wrap looks similar to what is shown in Fig. 39.

INSTALLATION PROCEDURE (Continued):

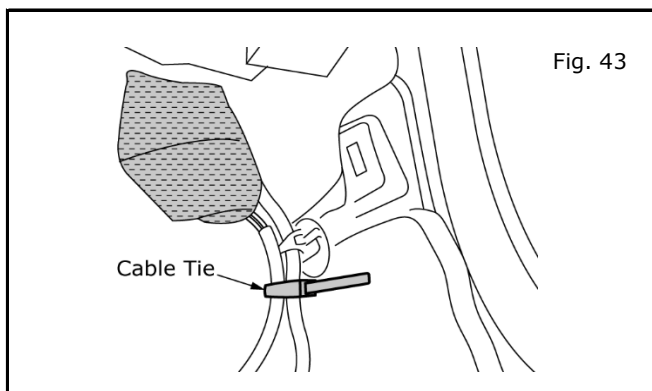
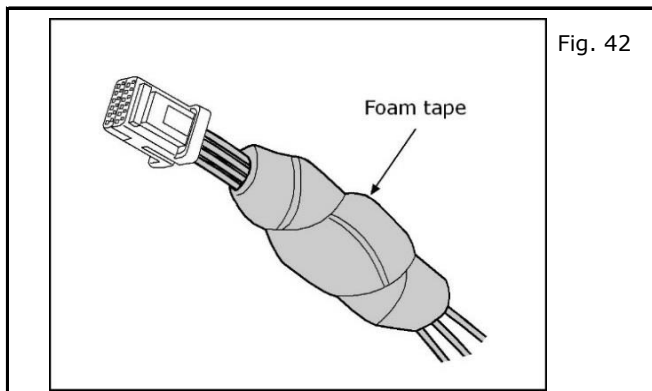
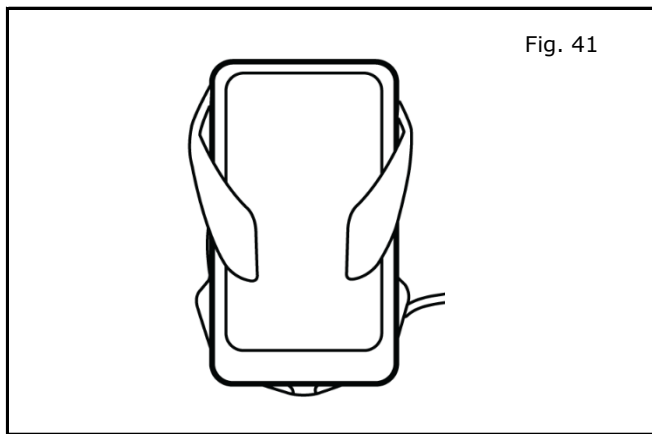
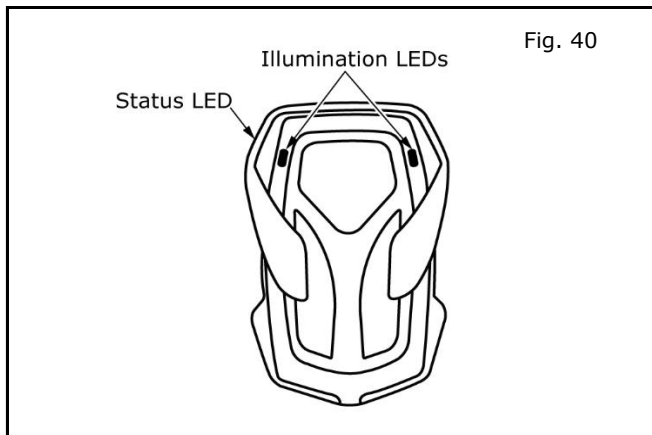

- 36) Check Wireless Charger module function.
- a) Connect Accessory Service Connector to vehicle harness
 - b) Connect harness to module.
 - c) Reconnect battery.
 - d) Place vehicle ignition in ACC position.
 - e) Two illumination LEDs will light, The status LED will blink RED and then turn off.

Check Wireless Charger module function (continued)

- f) Optional: If mobile device compatible with Qi specification is available, place device in charging surface. Status LED will blink red once and then flash green. Mobile device should indicate it is charging.
- g) Turn off vehicle.
- h) Disconnect battery.
- i) Disconnect Accessory Service Connector.

- 37) Wrap posi-taps with several pieces of foam tape.

- 38) Secure bundle to existing harness near service connector.
- Tighten all cable ties. Cut off ends.

INSTALLATION PROCEDURE:

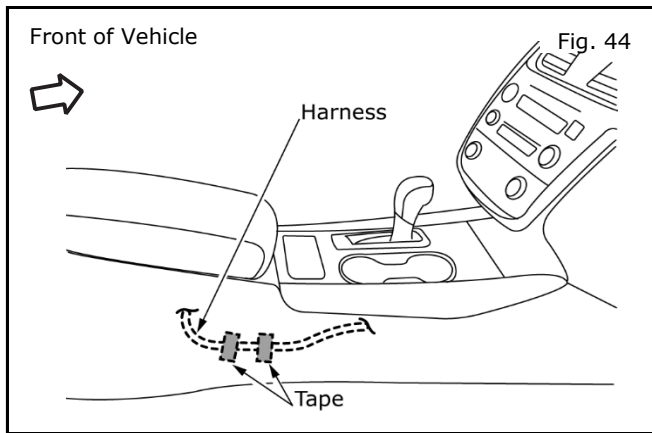

- 39) Using foam tape, secure harness to side of console box in two places.

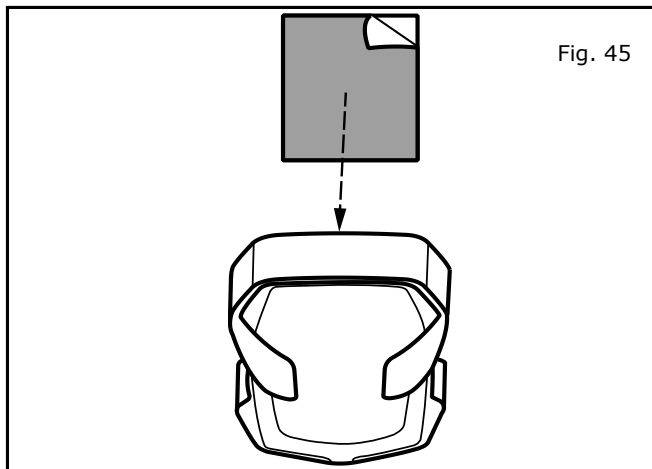

- 40) Prepare for Module Installation
- a) Clean location for mounting module with alcohol wipe. Allow to dry for one minute.

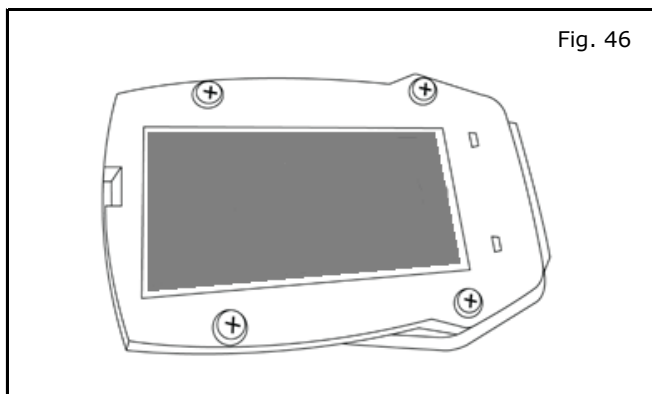

- 41) Install Module to Bin
- a) Peel off white layer of paper from double sided tape and stick to back of module
- b) Remove red side of double sided tape.

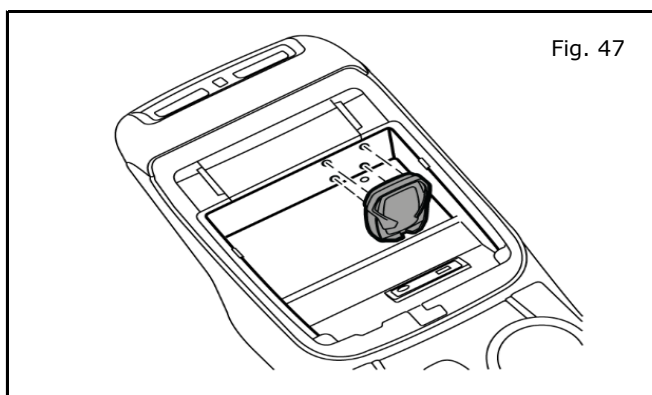

- c) Align four bosses on back of module with four previously drilled pilot holes.
- d) Press and hold module to bin to with 15lbs of pressure for 30 seconds.

INSTALLATION PROCEDURE:

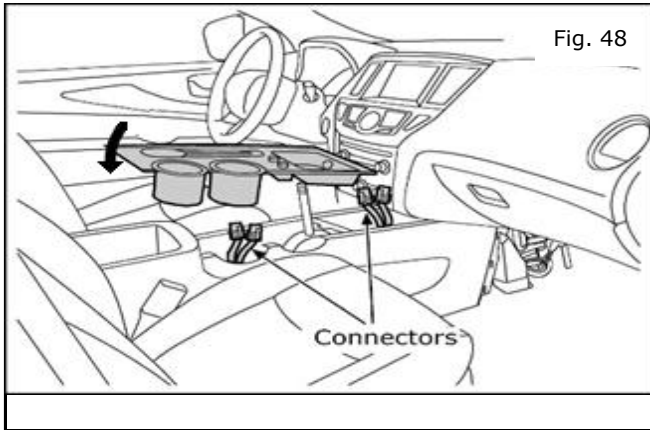

- 42) Reconnect other harness connectors to finisher panel.

Firmly insert harness connector.

Listen for "Click" to confirm.

Apply a slight tug to connector to check.

NOTE:

Number of connectors will vary by model and vehicle equipment.

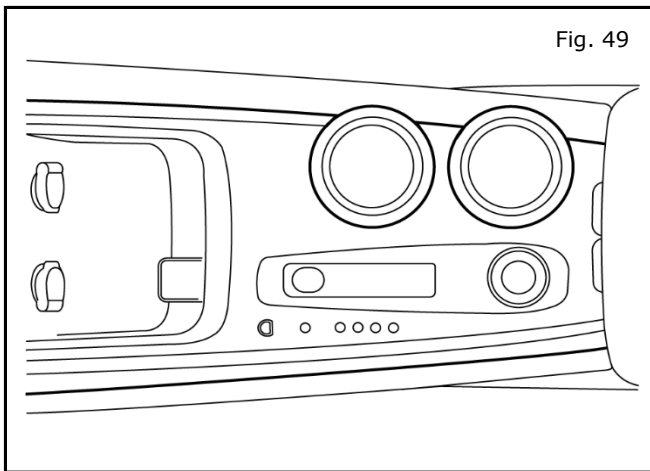

- 43) Reinstall AT finisher panel harness.

a) Return harness to original position.

b) Make sure harness and connectors are securely attached to original anchor points.

c) Reinstall shift knob assembly

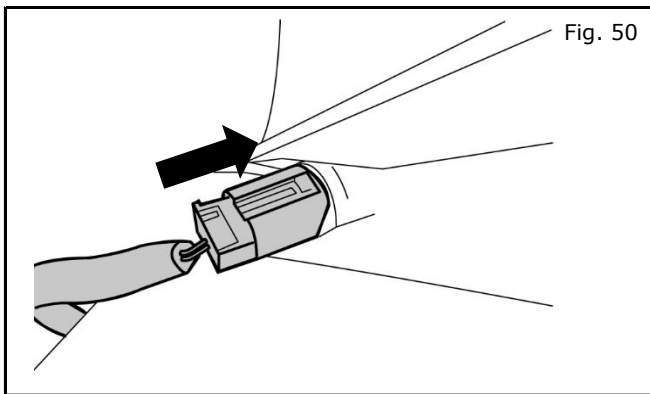

- 44) Assembling the A/T Trim

a) Re-connect harness to the 12 V power point.

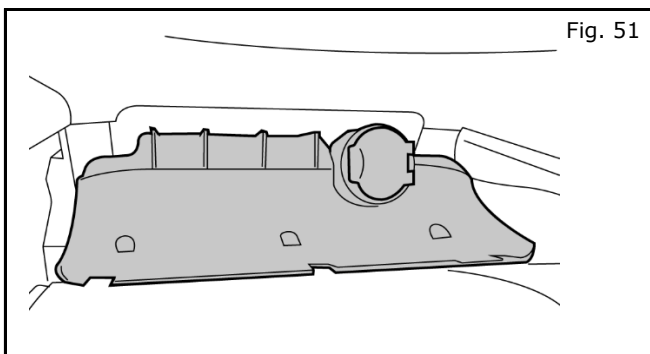

- 45) Assembling A/T Trim

a) Once the 12 V power point is connected, insert forward A/T finisher back into place.

b) Insert anti-slip liner back into place.

Re-assembly process:

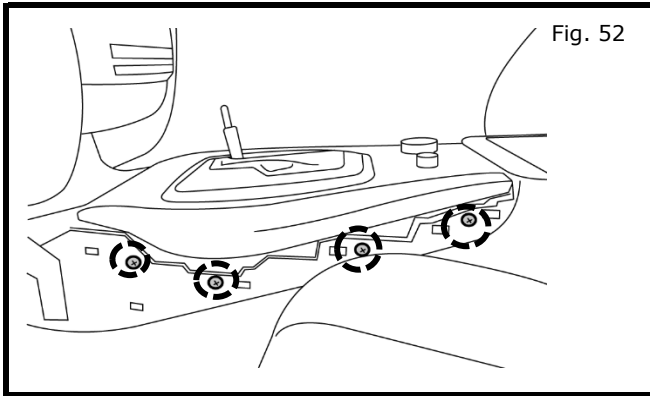

- 46) Re-Install A/T Finisher
- a) Once the been properly placed in it's original position, insert 4 screws into place and tighten using screw driver. Repeat on opposite side.

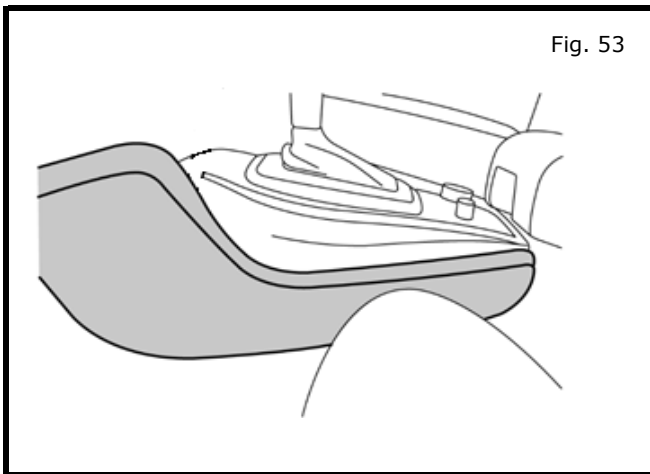

- 47) Re-Install Side Trim Panels RH/LH.

CAUTION

- Use caution when re-installing interior components to avoid damage, scratches, or breaking of mounting clips. Refer to the vehicle service manual for more information.

- Reinstall center finisher, AT finisher, and kick panels
- Connect harnesses to center console rear finisher connectors.
- Replace center console rear finisher.
- Reconnect battery, reprogram radio presets if required

FINAL INSPECTION:

- Verify re-installed trim parts for proper flush fit (no gap, no waviness, etc.).
- Verify all clips are fully engaged and locked.
- Verify re-installed trim parts are free from cracks, scratches or stress marks.
- Verify vehicle headliner, seat, steering wheel, center console, floor carpets, etc. are not soiled.
- Verify interior and exterior is not damaged.
- Turn ignition switch to "ON" and confirm proper operation of Vehicle Systems
 - If equipped, verify all window and sunroof one touch operation and perform the reset procedure if necessary. Refer to the vehicle service manual for more details.
 - Confirm proper audio function (AM, FM, SAT, CD and AUX).
- Start engine and verify that there are no new Diagnostic Trouble Code. Turn ignition switch to "**OFF**".
- Place the Owner Manual, Quick Reference Guide, and/or other Manual in the glove box.
- If this vehicle will be returned to a dealer lot or showroom for an extended period of time, be sure the extended storage switch is placed in the "inventory" position. Refer to the Extended Storage Switch verbiage at the beginning of the 'INSTALLATION PROCEDURE' section.

14. BILL OF MATERIALS:

Wireless Charging Kit - 999F7 V4300

Item	Part Description	Qty.	Service Part Number
A	Wireless Charging Module	1	999F7 V4006
B	Harness Assembly	1	999F7 V4002
C	Wire Tie	8	
D	Foam Tape	11	
E	Posi-Taps	2	999M1 VT000
F	Drilling Template	1	T98F7 6SA0A
G	Quick Reference Guide	1	999F7 V3010
H	II Download Instructions Sheet	1	999V2 AW000
I	Double Sided Tape	1	
J	Poly Bag		

Wireless Charger

PASSENGER SIDE

ACCY_SER_CONN

ACC	3
GND	12

PURPLE

BLK

RED

BLK

TH12FW-NH

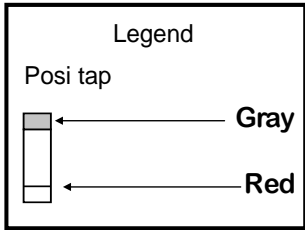
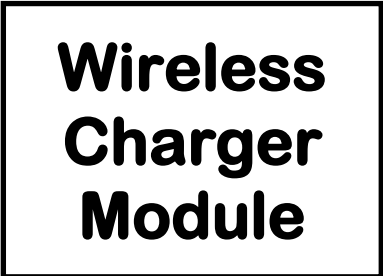
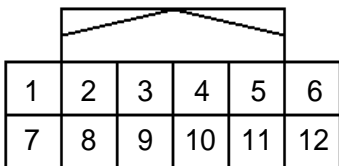

Note: Pin location is referenced looking into wire side of connector.

⚠ CAUTION

This Accessory Service Connector is for use only with Genuine Nissan (or Infiniti) or Nissan (or Infiniti) approved accessories. Use of this connector with non Genuine Nissan (or Infiniti) or Nissan (or Infiniti) approved accessories or failure to follow the installation instructions for the connector contained in this package may result in damage to the accessory and/or your vehicle. Nissan (or Infiniti) is not liable for loss or damage due to improper installation or the installation of non Genuine or non approved accessories.