



INFINITI.

# GENUINE PARTS

## INSTALLATION INSTRUCTIONS

- 1. **DESCRIPTION:** Radiant Grille Emblem
- 2. **APPLICATION:** Q50
- 3. **PART NUMBER:** F2890 6HA1A

### 4. KIT CONTENTS:

Item	Qty.	Description	Part Number
A	1	Illuminated Emblem	F2890 6HA0A
B	1	Installation Instruction Replacement Template	MANU0-AW001



A



B

### 5. TOOLS REQUIRED:

- Flathead screwdriver
- Masking Tape
- Needle nose pliers
- Clip Remover
- 10mm Socket & Driver
- 3mm (0.11811 inch) drill bit
- 5.4mm (0.212598 inch) drill bit
- 30 mm (1.1811 inch) holesaw

### 6. PRE-INSTALLATION CAUTIONS/NOTES:

- Dealer Installation Recommended.

### 7. INSTALLATION PATTERN:

### 8. INSTALLATION PROCEDURE:

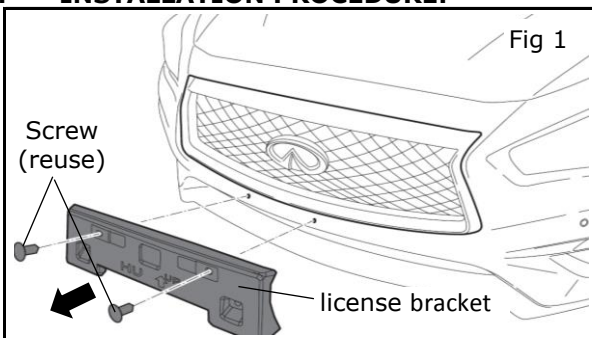

- 1) Remove 2 screws that attach to the license bracket and licence bracket (Keep to reuse).

**INSTALLATION PROCEDURE:** (continue)

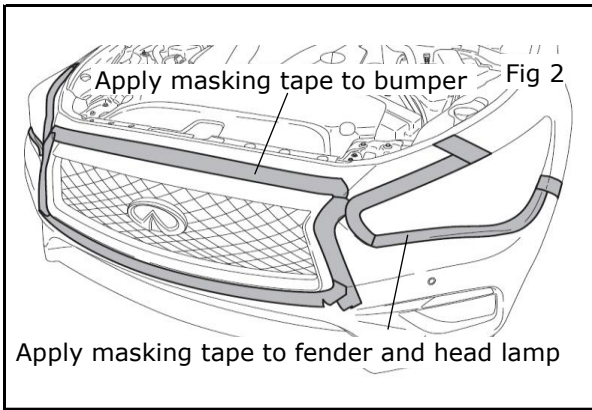

- 2) Open the vehicle engine hood.
- 3) Apply masking tape to front fender, head lamp and bumper, around the grille, to prevent scratches.
- 4) Keep turning the wheel to the left or right direction.
- 5) Disconnect the vehicle battery (negative terminal).

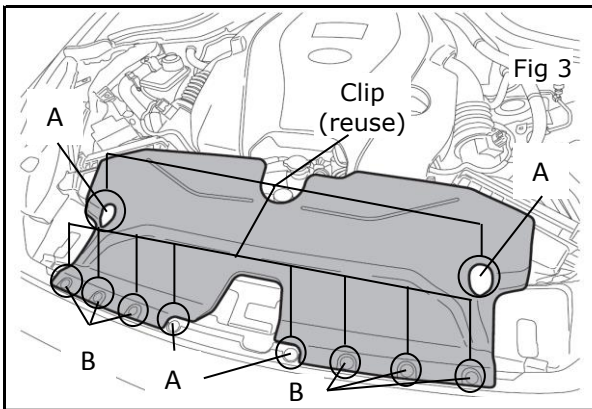

- 6) Remove 10 clips that attach air duct to the vehicle (Keep to reuse).  
※The clip must be careful because the two kinds.  
Clip A(Cross type) : 4 Clips  
Clip B(Triangle type) : 6 Clips

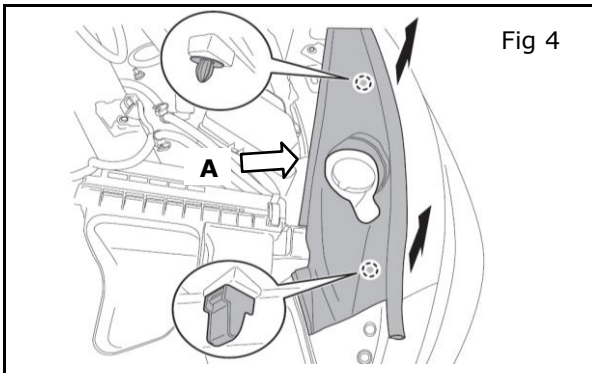

- 7) Partially detach the front end of a two claw of the fender side seal by pulling upward.  
For degradation Hand, or clip remover use.  
(LH/RH, both sides)

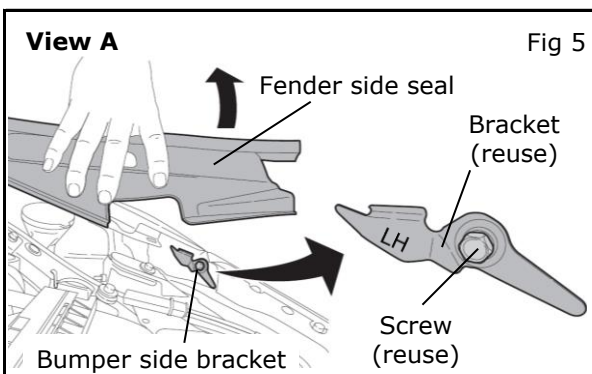

- 8) While pulling upward the fender side seal, detach screw that attaches a front bumper side bracket and remove the bracket (Keep to reuse).  
(LH/RH, both sides)

**INSTALLATION PROCEDURE:** (continue)

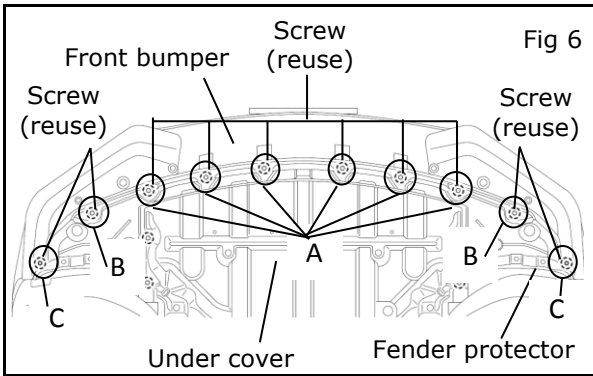

- 9) Detach 6 screws A on under cover (Keep to reuse).
- 10) Detach 2 screws B on fender protector on each side (Keep to reuse).
- 11) Detach 2 screws C on front bumper on each side (Keep to reuse).

※The clip must be careful because the two kinds.

Screw A(Without cross hole) : 6 Screws

Screw B,C(With cross hole) : 4 Screws

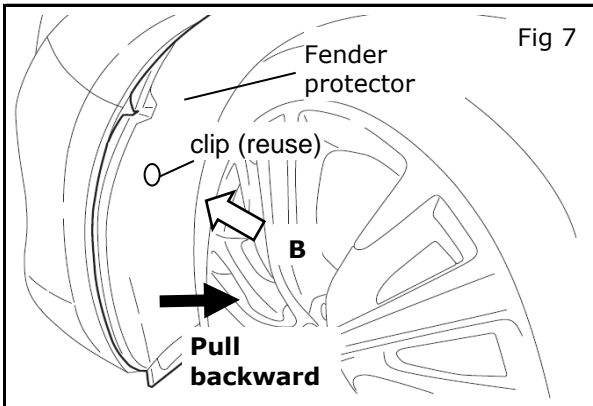

- 12) Detach clip in the wheel house (Keep to reuse) and pull the fender protector to backward. (LH/RH, both sides)

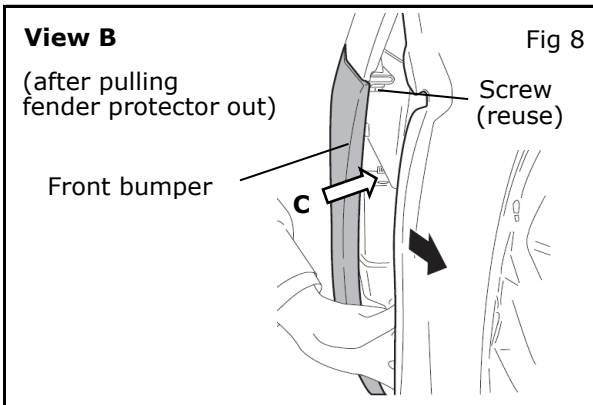

- 13) Detach screw which is behind the front bumper (Keep to reuse). (LH/RH, both sides)

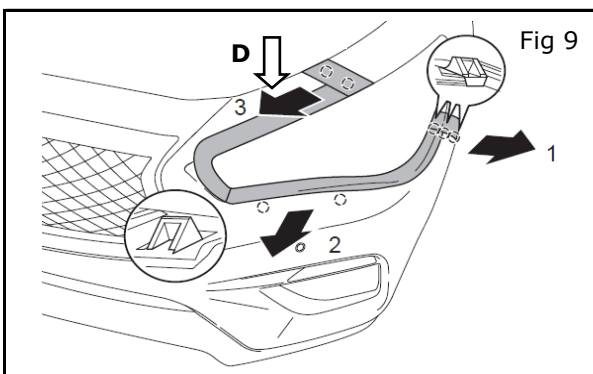

- 14) Detach the bumper fascia from the claws of vehicle fender and head lamp by pulling in the direction of the arrow 1,2 and 3. (LH/RH, both sides)

**INSTALLATION PROCEDURE:** (continue)

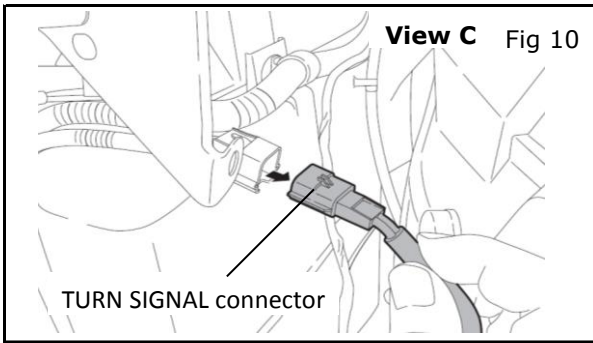

- 15) During bumper fascia removal, pull bumper forward, pull off the TURN SIGNAL connector. (LH/RH, both sides)

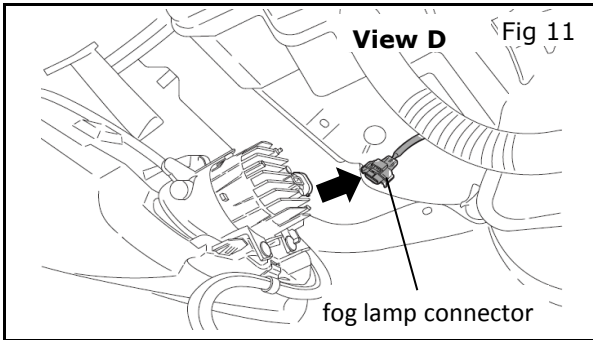

- 16) During bumper fascia removal, pull bumper forward, pull off the fog lamp connector. (LH/RH, both sides)

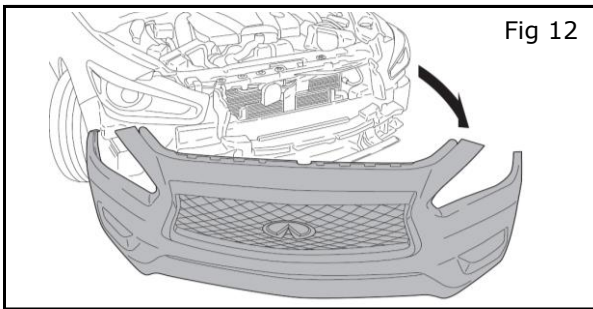

- 17) Remove the bumper from the vehicle. However, because the RH side wiring can not be removed, Pull out the LH side towards you so you can work.

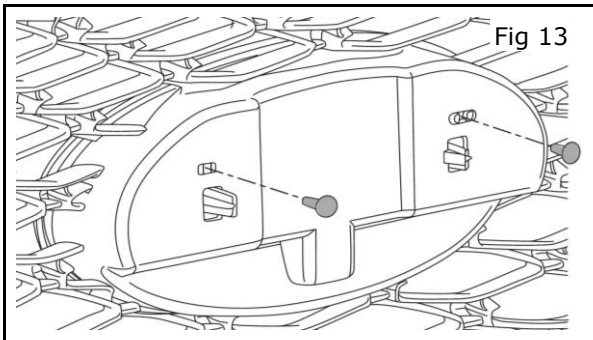

- 18) Remove 2 screws that attach to vehicle emblem. (keep to resuse).

**INSTALLATION PROCEDURE:** (continue)

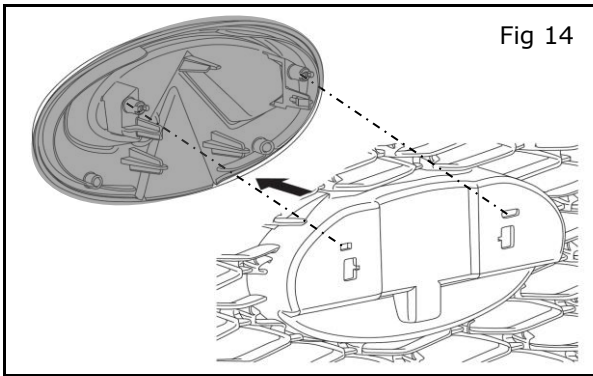

19) Remove vehicle emblem.

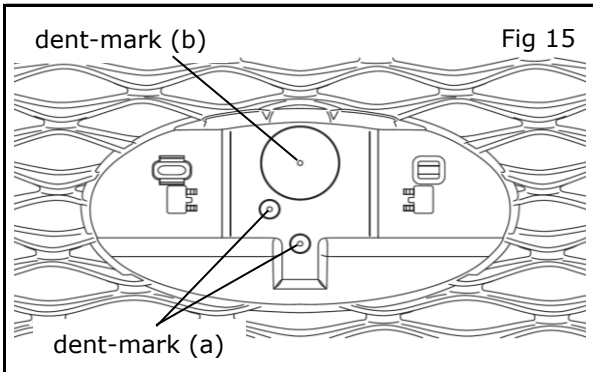

20) Drill 3mm (0.11811 inch) pilot holes to dent-marks; (a)×2, (b)×1.

21) Drill 5.4±0.2 mm (0.212598±0.007874 inch)holes to (a).

22) Drill a 30 mm (1.1811 inch) hole to (b).

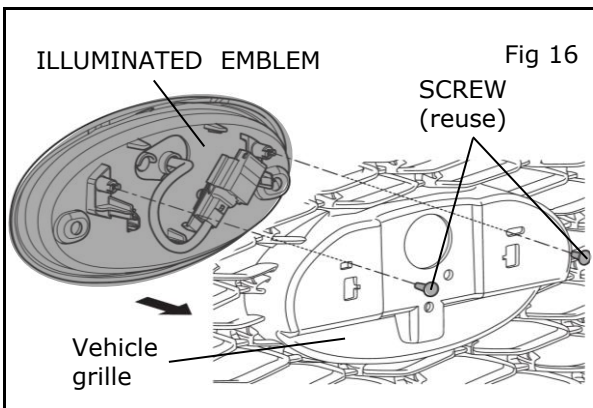

23) Install ILLUMINATED EMBLEM with 2 screws to vehicle grille.

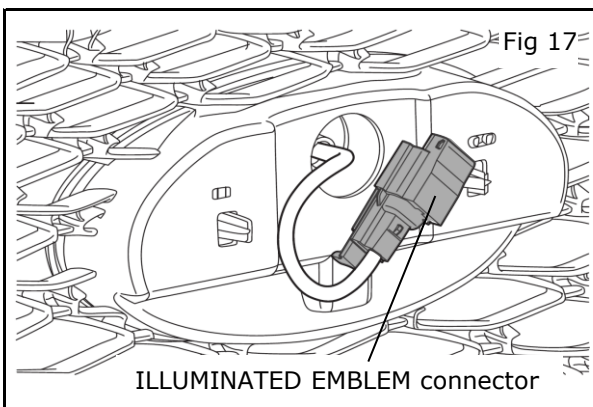

24) Install ILLUMINATED EMBLEM connector to vehicle grille.



**INSTALLATION PROCEDURE:** (continue)

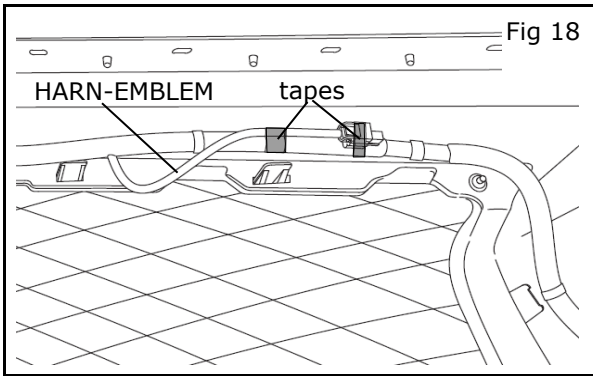

25) Break tapes of HARN-EMBLEM (pre-wired).

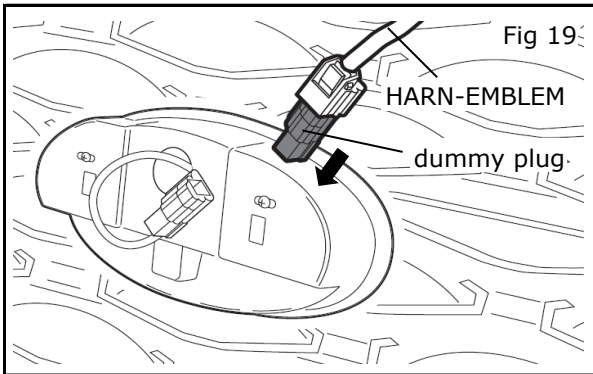

26) Remove dummy plug from HARN-EMBLEM connector (pre-wired).

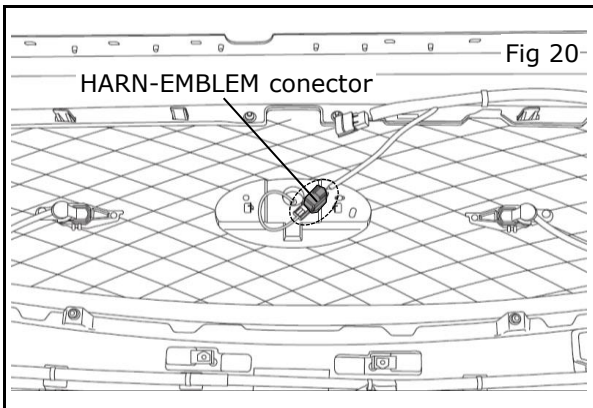

27) Attaching the HARN-EMBLEM connector to EMBLEM connector in Radiant Grille Emblem back side.

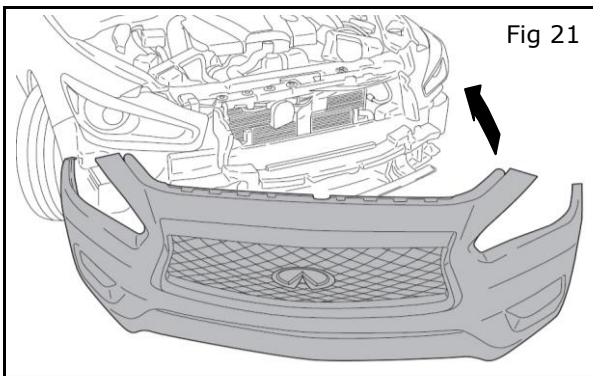

- 28) Place bumper fascia to vehicle without fixing.
- 29) Attaching the fog lamp connectors and TURN SIGNAL connectors, RH/LH sides.
- 30) Reinstall all removed parts in reverse order.
- 31) Connect the vehicle battery (negative terminal.)
- 32) Refer to REMOVAL AND INSTALLATION (FR BUMPER): Check Clearance and Surface Height Difference.
- 33) Remove any remaining masking tape.
- 34) Close the vehicle engine hood.

**Functional check :**

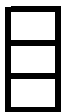

**Verify re-installed parts for proper flush fit.**  
**Please carry out lighting confirmation of Fog Lamp and EMBLEM.**  
**Perform camera image calibration. Refer to CALIBRATING CAMERA IMAGE (AROUND VIEW MONITOR) ,if aiqupped. : Special Repair Requirement.**