



INFINITI

GENUINE PARTS

INSTALLATION INSTRUCTIONS

DESCRIPTION: TOW HITCH FINISHER KIT

APPLICATION: QX50

PART NUMBER: T99T5 5NA2A

CONTENTS:

Item	Qty.	Part Description	Service Part Number
A	1	TOW HITCH FINISHER	T99T5 5NA8A
B	2	CLIP - PUSH PINS	N/A
C	1	Installation Instruction Replacement Template	N/A

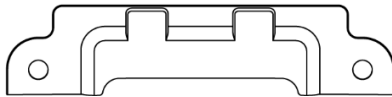

A

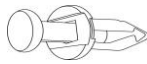

B



C

TOOLS REQUIRED:

- Safety Glasses
- Tape
- Drill
- 8mm Drill Bit
- Utility Knife

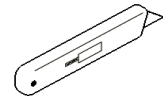
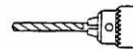
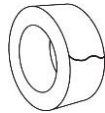

PRE-INSTALLATION WARNINGS, CAUTIONS, CRITICAL STEPS, and NOTES:

- Dealer Installation Recommended. Instructions may refer to Service Manual.

⚠ CAUTION

- Be careful of sharp edges under vehicle.
- Install the RR Fascia Finisher only when the part & vehicle temperature are between 60°F - 110°F (16°C - 43°C).
- Ensure that vehicle liftgate is closed
- Exhaust may still be hot

INSTALLATION PROCEDURE:

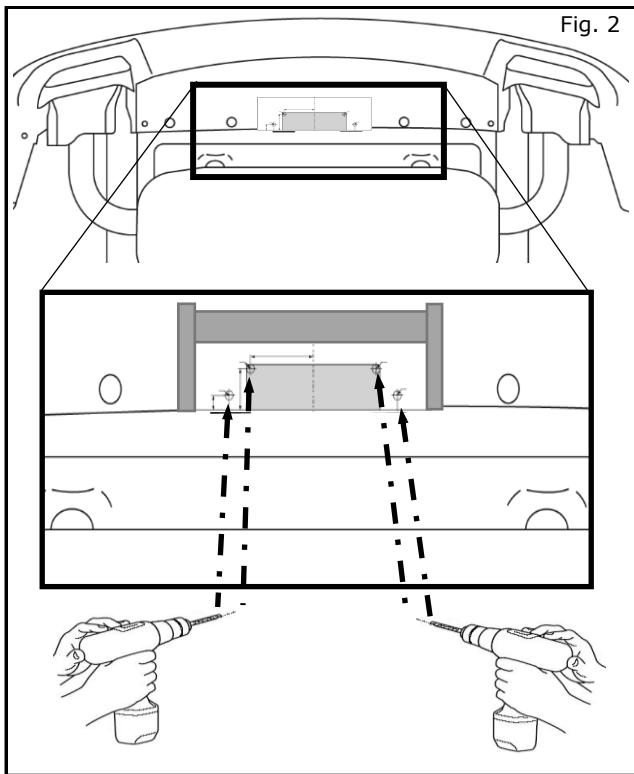
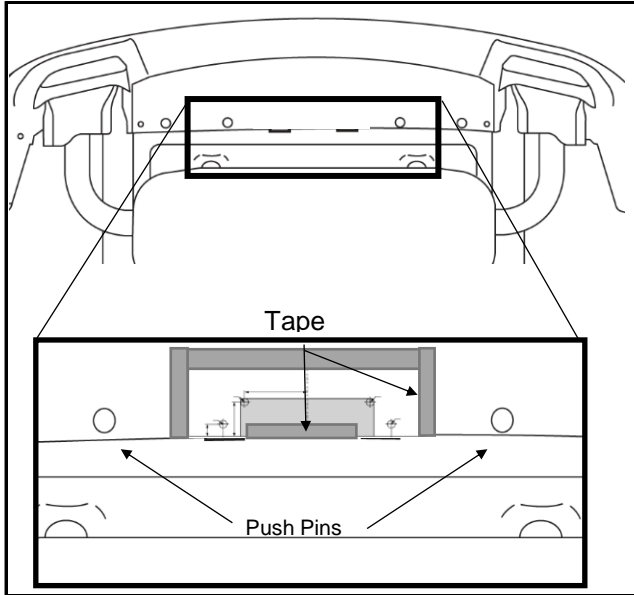

- 1) Clean Rear Fascia thoroughly with soap and water to remove any dirt or debris and allow to dry.
- 2) Raise and secure vehicle on lift
- 3) Attach cutting template to rear fascia
 - a) Attach cutting template to rear fascia, centering template between push pins on fascia
 - b) Secure outside edge of cutting template with tape as shown.

NOTE: Tape should hold cutting template securely to fascia. Any looseness can cause problems with rear fascia finisher fit.

- 4) Trim Rear Fascia with cutting template
 - a) Drill four(4) 8mm holes as shown on Cutting Template. See figure 1 and figure 2.
 - b) Cut out cross-hatched area on Cutting Template with small reciprocating saw.
 - c) Remove cutting template and tape from rear fascia
 - d) Clean edge of cut line to remove any burrs or flash from the drilling and cutting process

NOTE:

Cut line on rear fascia should not have any sharp edges. Remove all sharp edges and burrs

INSTALLATION PROCEDURE:

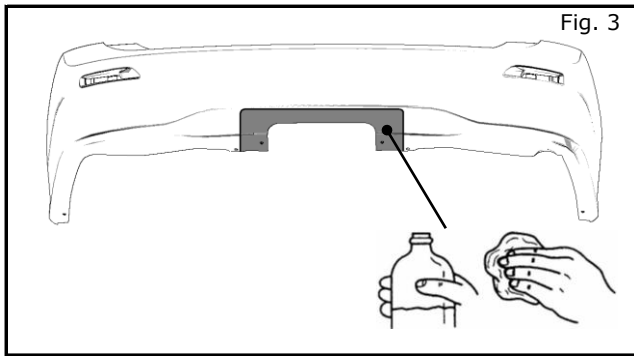

- 6) Clean rear fascia with damp cloth. Ensure area is free of dirt and debris.

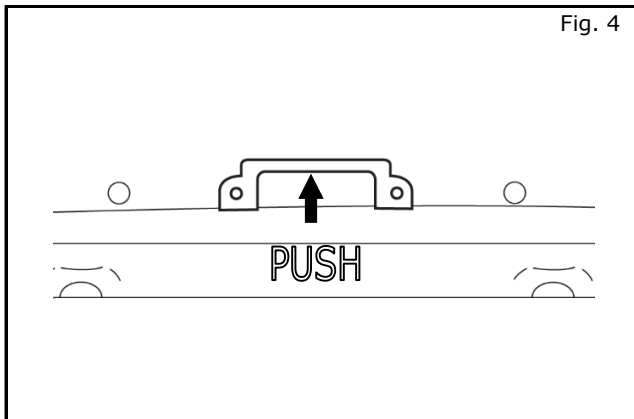

- 7) Install Finisher to Fascia. Locate Finisher to rear fascia. Push center of hitch finisher rearward onto fascia. See figure 4.

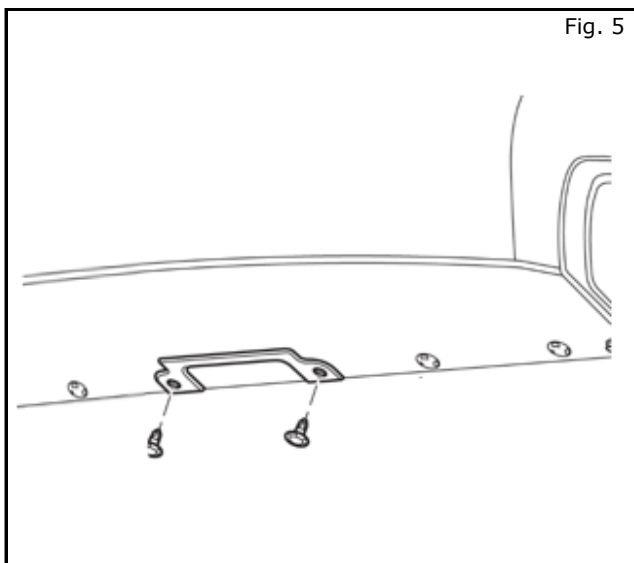

- 8) Install 2 Push Pins. See figure 5.

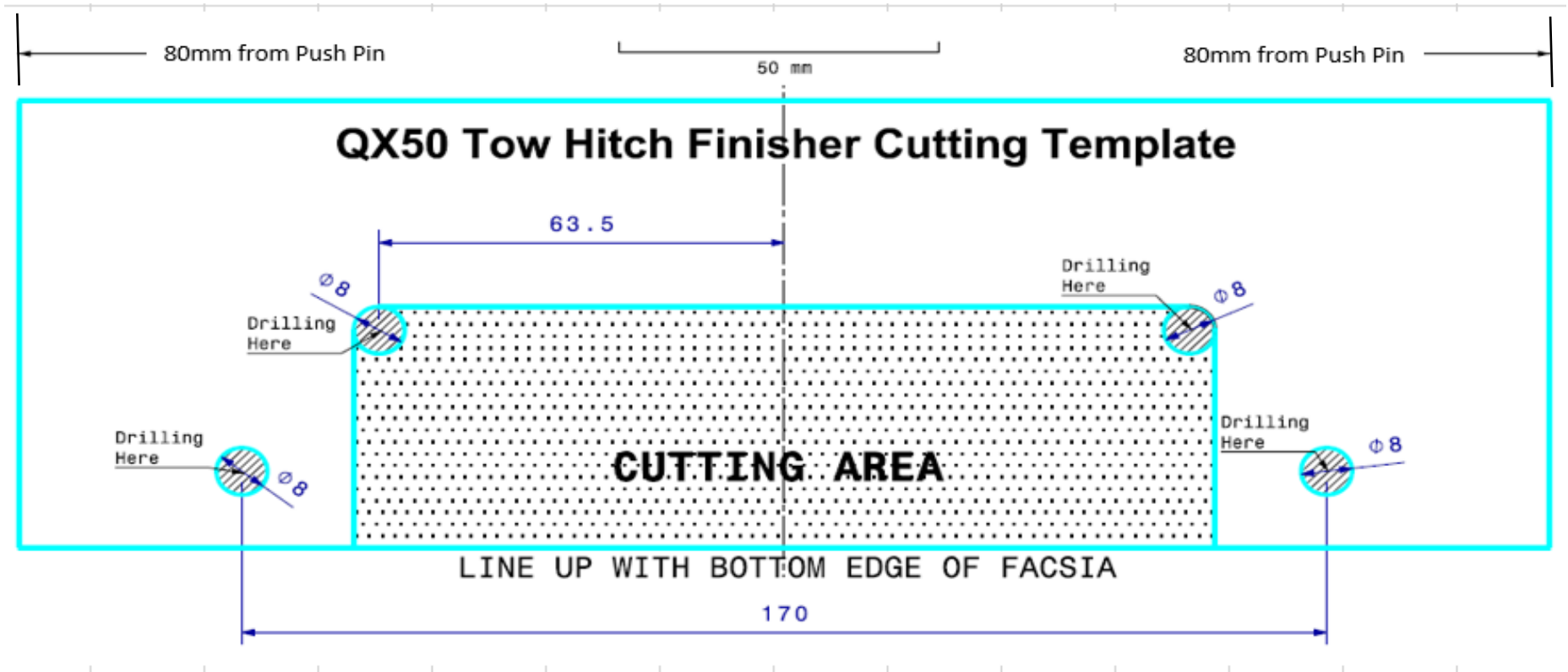

CUTTING TEMPLATE FOR P71A TOW HITCH FINISHER

**NOTE: CONFIRM CUTTING TEMPLATE IS PROPER SIZE.
REFERENCE 50MM SCALE AT TOP OF CUTTING TEMPLATE**