



INFINITI.

GENUINE PARTS

INSTALLATION INSTRUCTIONS

DESCRIPTION: Rear Bumper Protector

APPLICATION: QX50

PART NUMBER: T99B1 5NA00

KIT CONTENTS:

Item	Qty.	Part Description
A	1	Rear Bumper Protector
B	2	Installation Template
C	1	Installation Instruction Replacement Template

TOOLS REQUIRED:

- Clean Lint Free Cloth
- 90% or Greater Isopropyl Alcohol
- Masking Tape

PRE-INSTALLATION WARNINGS, CAUTIONS, CRITICAL STEPS, and NOTES:

- Dealer installation recommended. Instructions may refer to Service Manual.

 **CAUTION**

- Please wash vehicle with soap and water prior to bumper protector installation.
- Do not wash vehicle for at least 24 hours after installing bumper protector. Doing so can lead to poor adhesion between bumper protector and vehicle.
- Install bumper protector only when part and vehicle temperature are between 16°C - 43°C (60°F - 110°F).
- Failure to clean mounting surface properly can lead to poor adhesion between bumper protector and vehicle.
- Failure to apply sufficient pressure to wet out all tape lengths can cause bumper protector to not adhere properly.
- Do not tack front tape strips to vehicle before rear tape strips. Tacking front tape strips first will prevent removal of rear tape liners.
- To allow time for adhesive to cure, maintain vehicle temperature between 16°C - 43°C (60°F - 110°F) for at least 2 hours after installing bumper protector.

INSTALLATION PROCEDURE:

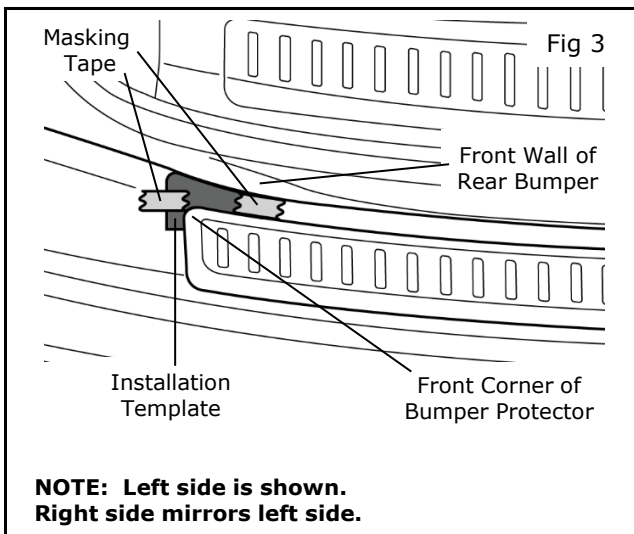
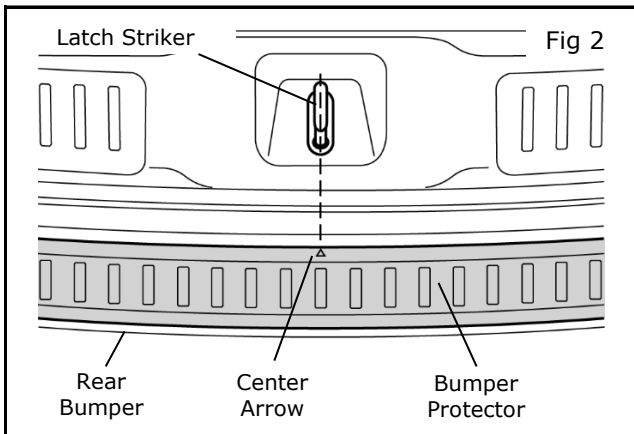
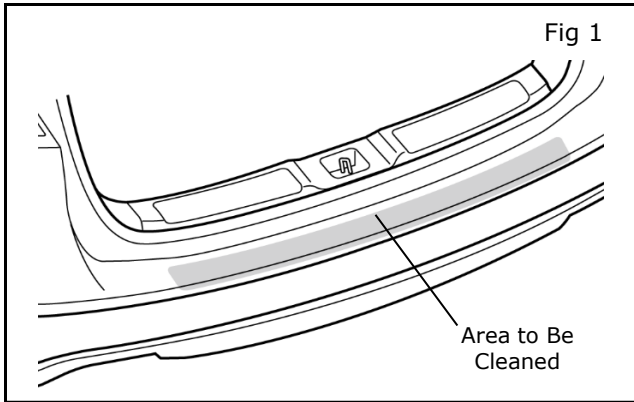

- 1) Open rear hatch door.
- 2) Clean attachment area of vehicle (shaded area).
 - a) Wash with soap and water to remove any dirt and debris. Allow time to dry.
 - b) Cleanse with clean lint free cloth and 90% or greater isopropyl alcohol. Allow time to dry.

NOTE:

Failure to clean mounting surface properly can lead to poor adhesion between bumper protector and vehicle.

- 3) Dry fit bumper protector on vehicle. Align bumper protector center arrow with tailgate latch striker.

NOTE:

Do not remove tape liners.

- 4) At both ends of bumper protector, position installation template between front wall of rear bumper and front corner of bumper protector.

NOTE:

Installation templates should fit tightly between bumper protector and front wall of rear bumper.

- 5) Secure installation templates to bumper with masking tape.

- 6) Remove bumper protector.

INSTALLATION PROCEDURE:

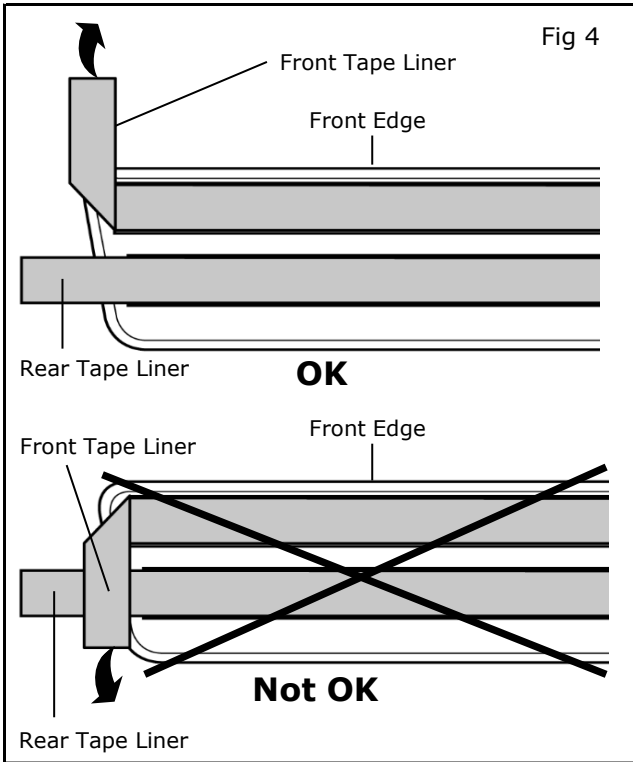

- 7) At both ends of bumper protector, fold front tape liner so it will extend beyond front edge of part without exposing adhesive.

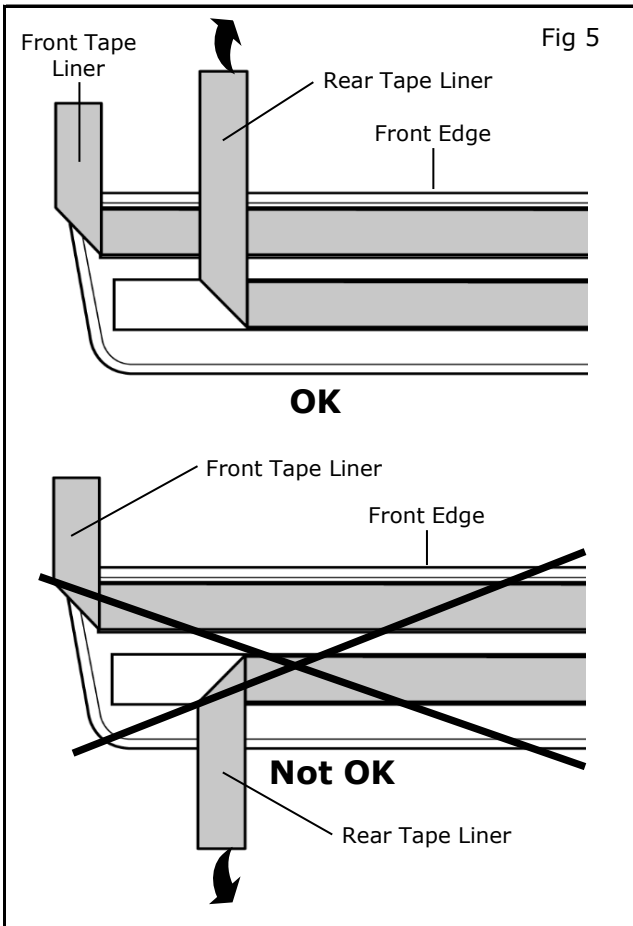

- 8) Prepare rear tape.
- a) At both ends of bumper protector, peel back rear tape liner approximately 25 mm (1 in).
 - b) At both ends of bumper protector, fold rear tape liner so it will extend beyond front edge of part.

INSTALLATION PROCEDURE:

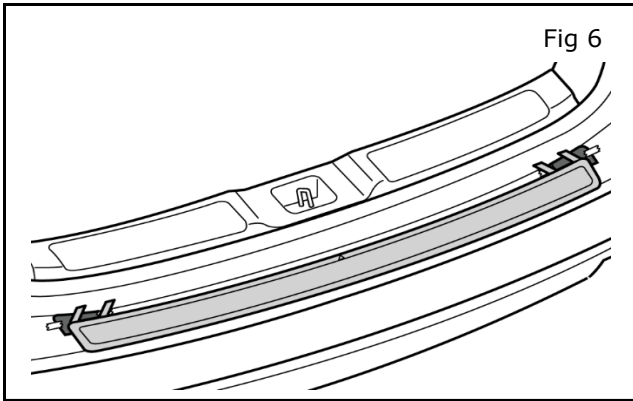

- 9) Realign bumper protector to tailgate latch striker and installation templates, and apply gentle pressure to lightly tack both ends of part to vehicle.

NOTE:

Do not apply firm pressure.

- 10) Confirm center arrow alignment and tight fit to installation templates. If necessary, untack bumper protector and repeat.

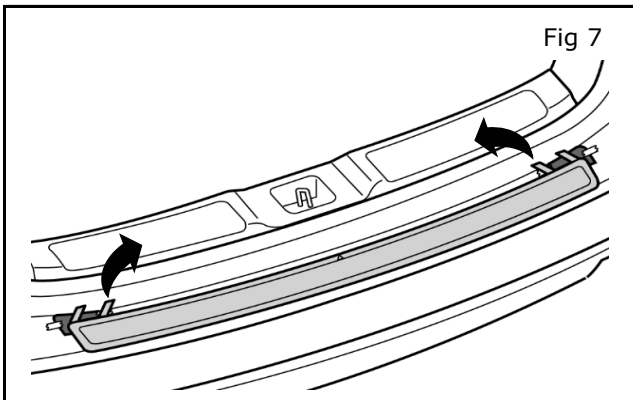

- 11) While gently lifting up on front edge of bumper protector, remove rear tape liners by slowly pulling along length of part towards center.

NOTE:

Do not tack front tape strips to vehicle before rear tape strips. Tacking front tape strips first will prevent removal of rear tape liners.

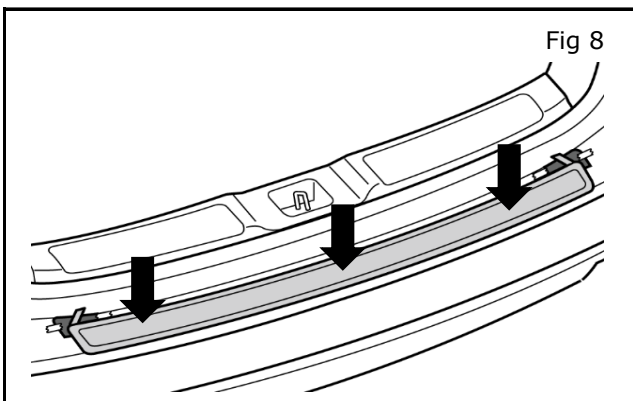

- 12) Using clean lint free cloth, apply 1 kg/cm^2 (15 lb/in^2) of firm pressure along rear tape path. Start from center and work outward in one direction. Repeat in opposite direction.

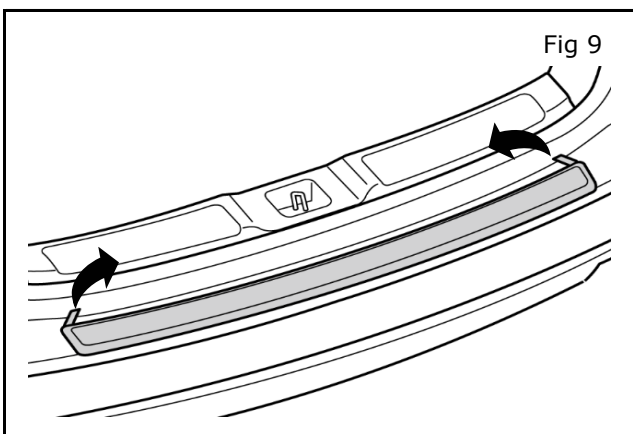

- 13) Remove and discard installation templates.

- 14) While gently lifting up on front edge of bumper protector, remove front tape liners by slowly pulling along length of part towards center.

INSTALLATION PROCEDURE:

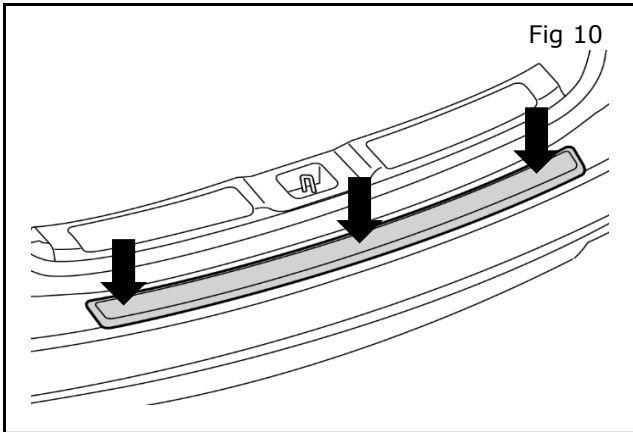

- 15) Using clean lint free cloth, apply 1 kg/cm^2 (15 lb/in^2) of firm pressure along front tape path. Start from center and work outward in one direction. Repeat in opposite direction.
- 16) To ensure adequate adhesion, reapply 1 kg/cm^2 (15 lb/in^2) of firm pressure across entire bumper protector.
NOTE:
Failure to apply sufficient pressure to wet out all tape lengths can cause bumper protector to not adhere properly.
- 17) Remove and discard protective film.
- 18) Close rear hatch.
- 19) Maintain vehicle temperature between 16°C - 43°C (60°F - 110°F) for at least 2 hours, and do not expose vehicle to moisture for at least 24 hours. This will allow time for tape to cure.