



GENUINE PARTS

INSTALLATION INSTRUCTIONS

- 1. **DESCRIPTION:** MOONROOF WIND DEFLECTOR
- 2. **APPLICATION:** Infiniti QX
- 3. **PART NUMBER:** 999D4 3X000

4. **KIT CONTENTS:**

Item	QTY	Description
A	1	Moonroof Deflector
B	3	Phillips Head Screw (16mm length)
C	3	Nylon Washers
D	3	Nylon Nuts
E	2	Side Brackets
F	1	Center Bracket
G	3	Protective Tape
H	1	Installation Instructions Replacement Template

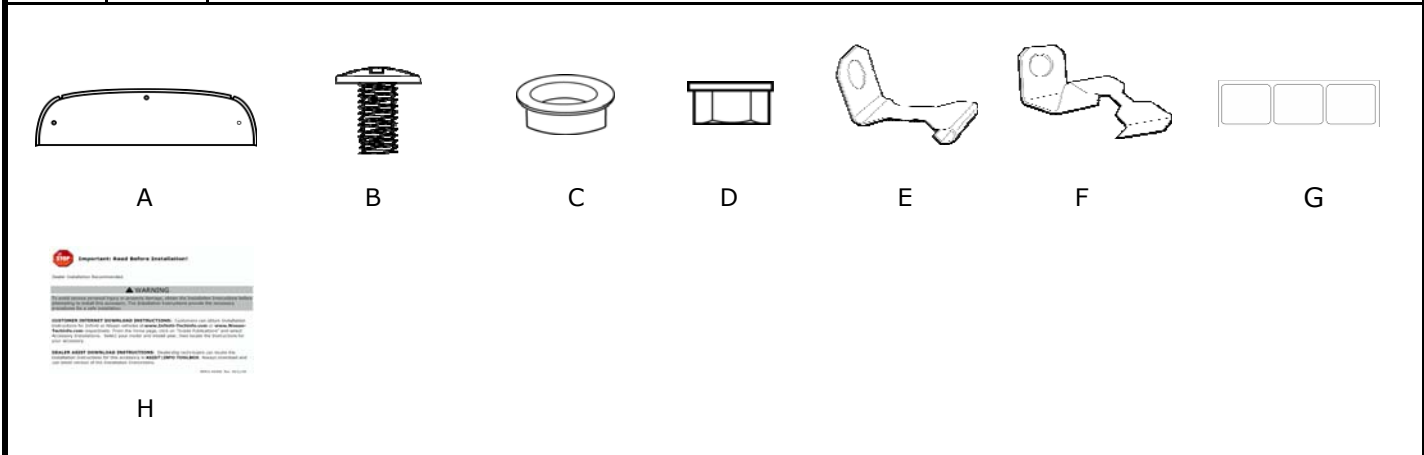

5. **TOOLS REQUIRED:**
- Rubbing Alcohol (90% or greater)
 - Measuring Tape or scale
 - Shop Towel
 - #2 Phillips Head Screw Driver
 - Felt Tip Pen
 - 10mm Wrench
 - Car Wash Supplies
 - Masking Tape

6. **CAUTIONS/NOTES:**
- To avoid damaging the surface, never use ammonia-based cleaners or solvents to clean your moonroof deflector.
 - Clean moonroof deflector with a solution of mild dishwashing soap and water using a soft cloth or chamois.
 - To remove fine scratches and restore the original luster, use a high quality plastic cleaner.

INSTALLATION INSTRUCTIONS - MOONROOF WIND DEFLECTOR

7. INSTALLATION PROCEDURE:

- 1) Open moonroof.
- 2) Clean roof installation area.
- 3) Clean inner edge (flange) of moonroof opening using rubbing alcohol and shop towel.
- 4) Push factory wind breaker down and insert shop towel to hold it in place.

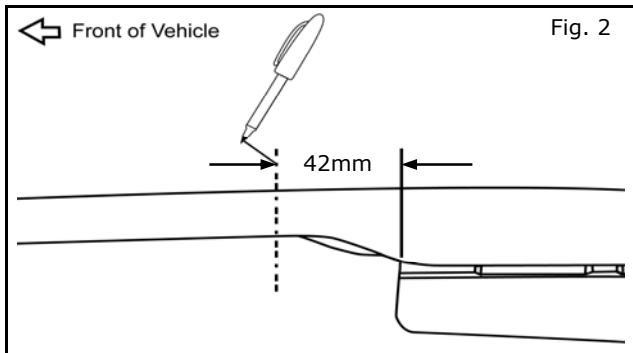
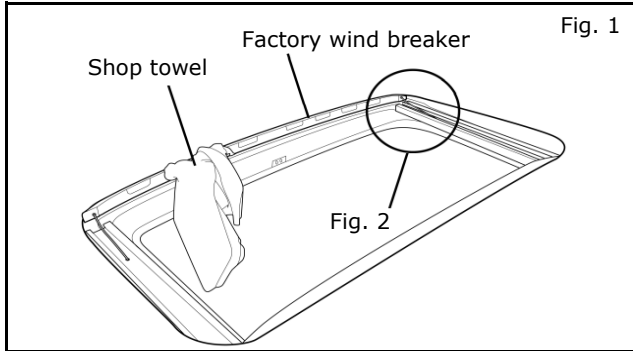

- 5) Side bracket rough locator (reference only): Measure 42mm forward from edge shown on passenger's side and mark location on flange using felt tip pen. Repeat for driver's side. This is a reference location only and may change depending upon adjustments made in step 15.

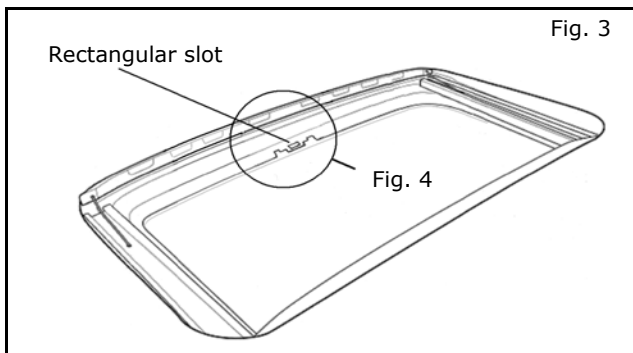

- 6) Center bracket location marking: Locate rectangular slot as shown.

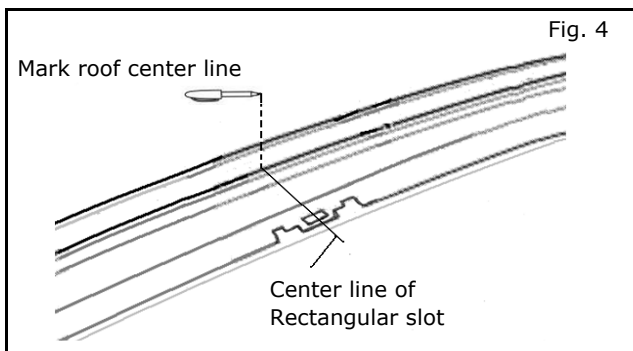

- 7) Center bracket location marking: Mark roof centerline on flange along center line of rectangular slot using felt tip pen.

INSTALLATION INSTRUCTIONS - MOONROOF WIND DEFLECTOR

7. INSTALLATION PROCEDURE (CONTINUED):

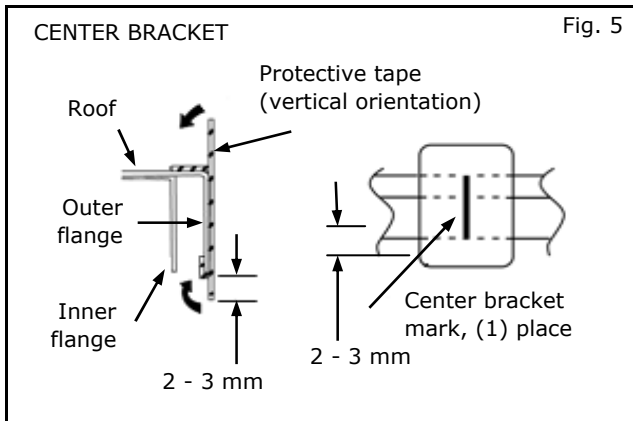

- 7) Attach protective tape to roof outer flange at center bracket mark using mark as centerline. Allow only 2-3mm of protective tape to hang below flange. Take note of tape orientation as shown (vertical). Wrap protective tape around bottom of outer flange, making sure it does not contact inner flange.

NOTE:

It is helpful to use a bracket to push the tape if it is interfering with the inner flange.

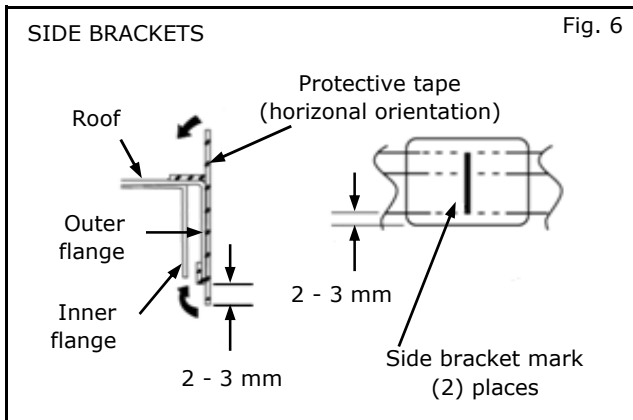

- 8) Attach protective tape to roof outer flange at each side bracket location using starting side bracket location as a guide. Allow only 2-3mm of protective tape to hang below flange. Take note of tape orientation as shown (horizontal). Wrap protective tape around bottom of outer flange, making sure it does not contact inner flange.

NOTE:

It is helpful to use a bracket to wrap the tape if it is interfering with the inner flange.

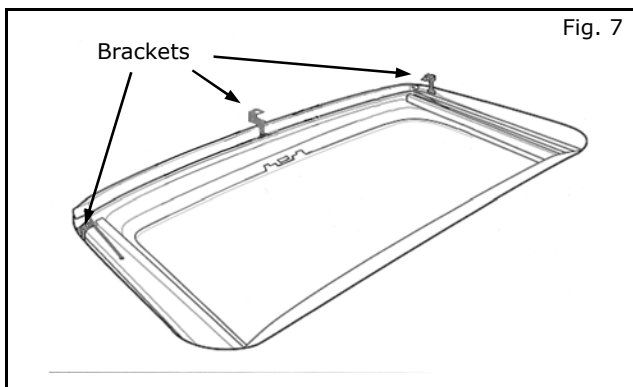

- 9) Center brackets over protective tape and temporarily secure each bracket in place using masking tape.

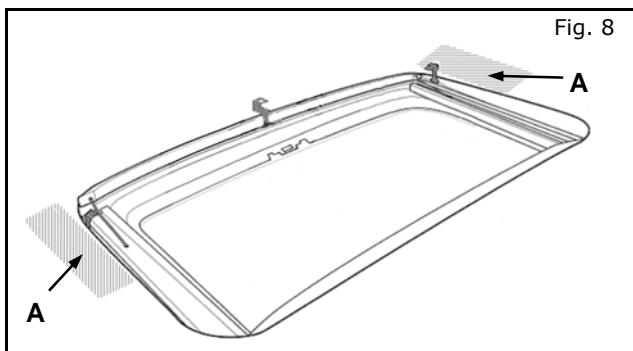

- 10) With a clean shop towel, thoroughly wipe areas marked "A" in Fig. 8 with alcohol (90% or greater concentration). Allow enough time for alcohol to flash/dry.

INSTALLATION INSTRUCTIONS - MOONROOF WIND DEFLECTOR

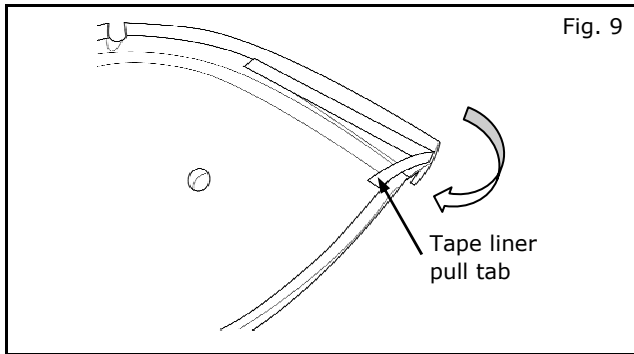

Fig. 9

11) Fold excess tape liner pull tab on both left and right sides of the moonroof deflector so it lays across inside edge of deflector seal, pointing toward interior of vehicle. Ensure that adhesive tape under liner is not yet exposed.

12) Set moonroof deflector on the roof so deflector holes are aligned with bracket holes.

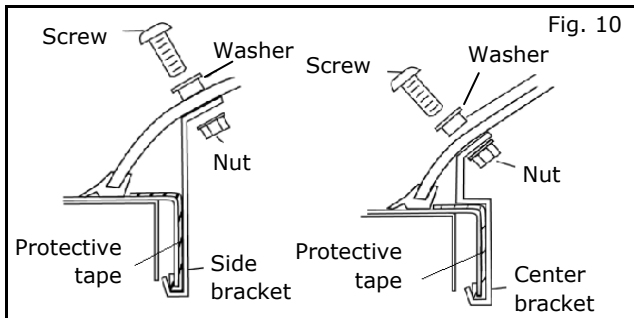

Fig. 10

13) Starting with side brackets, install washer and screw through moonroof deflector and bracket, loosely tighten nut and remove and discard masking tape.

14) Repeat step 13 for center bracket.

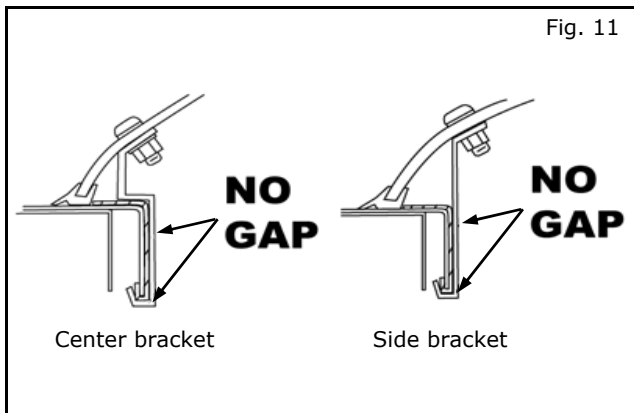

Fig. 11

15) Position moonroof deflector with equal spacing on all sides and then push forward to eliminate any gap between center bracket and flange.

⚠ CAUTION

Leaving air gap between brackets and flange can cause wind noise issues. Confirm there is no gap between brackets and flange. If there is any gap, adjust deflector and side brackets forward to eliminate gap. (Fig.11)

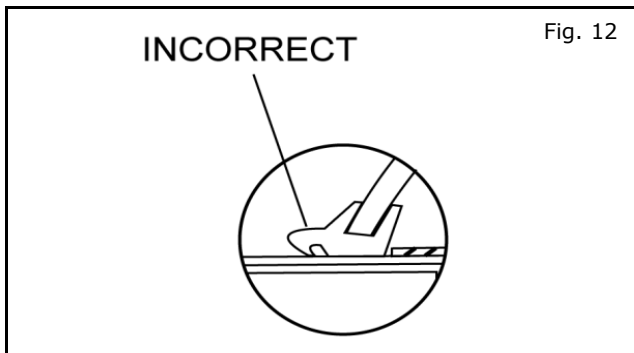

Fig. 12

16) Check that rubber seal is not twisted or rolled under deflector. If necessary, slide a credit card under rubber seal from inside to straighten it. Where there is adhesive tape on seal, slide a credit card from outside to straighten it.

17) Fully tighten center bracket screw. To prevent damage to nylon nuts, do not overtighten.

INSTALLATION INSTRUCTIONS - MOONROOF WIND DEFLECTOR

- 18) Carefully remove tape liners on either side of moonroof deflector. Lightly lift rear of moonroof deflector while pulling liner to reduce possibility of breaking liner. Take care not to cause any gap between brackets and flange.
- 19) Fully tighten side bracket screws. To prevent damage to nylon nuts, do not overtighten.
- 20) Apply downward hand pressure on the rubber seal to properly wet out the adhesive tape.
- 21) Remove shop towel holding the factory wind breaker down and close the moonroof.
- 22) Peel off and discard "Caution Label" attached to the top surface of the deflector.

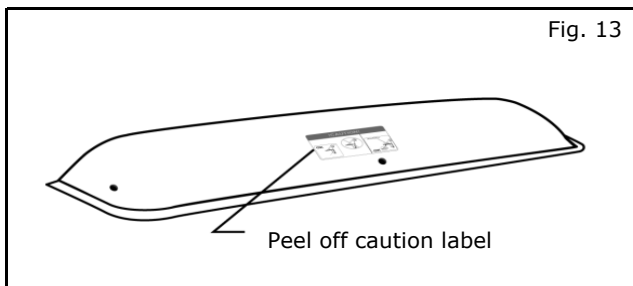

8. CHECKLIST:

Prior to completion, verify the following:

- Brackets are flush against flange. No gaps.
- Paint protection film is smooth and free of wrinkles.
- Rubber seal is not rolled under deflector.
- Close moonroof to confirm it operates normally.