



INFINITI®

GENUINE PARTS

INSTALLATION INSTRUCTIONS

DESCRIPTION: Nose Mask
APPLICATION: Infiniti G37 Coupe and Convertible Sport Model (2011)
PART NUMBER: 999N1 JX0CS

KIT CONTENTS:

Item	Qty.	Part Description
A	1	Nose Mask, Main Piece
B	1	Nose Mask, Hood Piece
C	1	Installation Instructions Replacement Template

TOOLS REQUIRED:

- Scissors
- Phillips Screwdriver

PRE-INSTALLATION CAUTIONS/NOTES:

- The area to be covered by the mask must be free of dirt. The flannel surface of the nose mask must be especially clean.
- Both the vehicle and the mask must be completely dry. If moisture is present under the mask and is allowed to dry, it may cause the paint to cloud. If mask gets wet, remove and allow to dry completely.
- Any repainted surface in contact with mask must be completely cured.
- DO NOT pull the mask from any of the openings when installing the mask. This may result in DAMAGE to your mask.
- If the nose mask should flap due to high speed or wind conditions, stop car and adjust or remove mask.

CARE OF NOSE MASK:

- To clean the vinyl and flannel backing, use a cleaner such as "409" or "Fantastic".
- The vinyl surface may be cleaned by simply spraying the cleaner onto the vinyl and wiping off with a cloth or sponge.
- To clean the flannel backing, liberally spray the cleaner on the area to be cleaned. If heavily soiled, use a cloth or sponge with the cleaner and rub the soiled area gently. Repeat if necessary. Rinse completely with clear water when finished. Hang to dry, but not in direct sunlight. Before installation, ensure both the vehicle and the nose mask are completely dry. If there is moisture under the nose mask and it is not allowed to dry, paint clouding can occur.

CAUTION

- Attach all elastics with hooks and clips carefully and securely. Accidental release may cause injury.

INSTALLATION INSTRUCTIONS - Nose Mask

INSTALLATION PROCEDURE:

- 1) Remove license plate and license plate bracket (if applicable).
 - a) Remove 2 license plate screws.
 - b) Remove 2 license plate bracket screws.

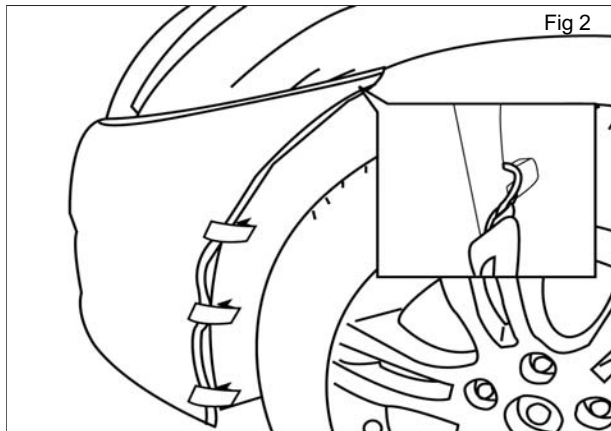

- 2) Install mask in wheel wells.
 - a) Attach hook above/behind clip.
 - b) Repeat step a) on other side.
 - c) Pull mask down.
 - d) Attach 3 clips to inside edge of fascia.
 - e) Repeat step d) on other side.

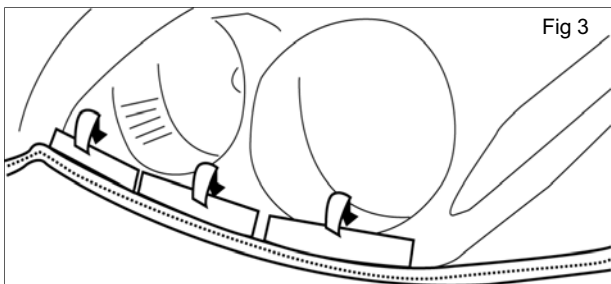

- 3) Install mask at headlights.
 - a) Insert the 3 front pads into gap under headlight.
 - b) Repeat step a) on other side.

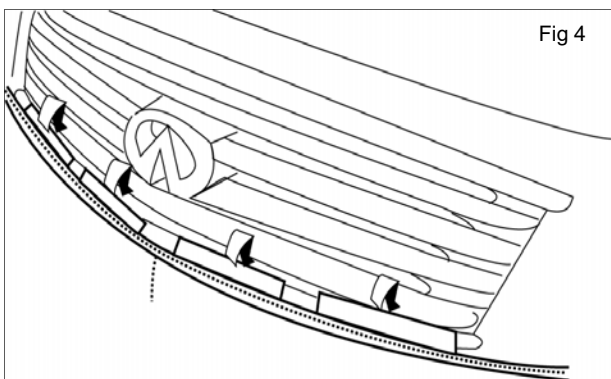

- 4) Install into upper grille opening.
 - a) Insert 4 pads into gap between upper grille and upper fascia.

INSTALLATION INSTRUCTIONS - Nose Mask

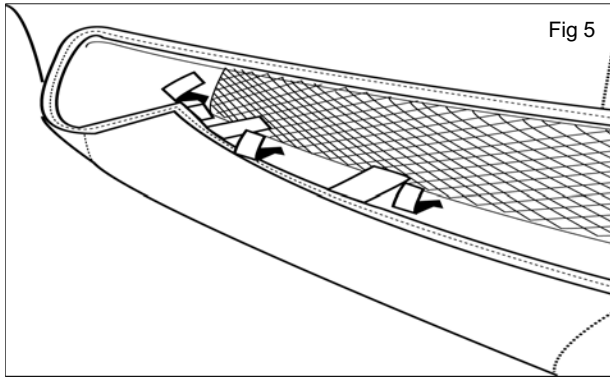

- 5) Install mask at lower grille opening.
 - a) Insert 3 pads into gap between lower grille and lower fascia
 - b) Repeat step a) on other side.

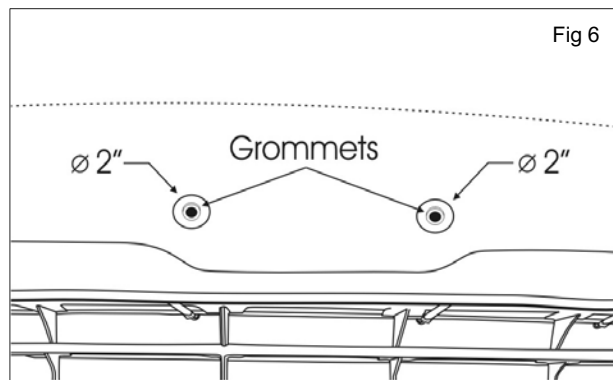

- 6) Reinstall license plate and license plate bracket (if applicable).
 - a) Poke holes through mask into center license plate bracket grommets.
 - b) Cut clearance holes (1"-2") so that license plate bracket pads will rest on fascia.
 - c) Reinstall license plate bracket and plate.