



## GENUINE PARTS

### INSTALLATION INSTRUCTIONS

1. **DESCRIPTION:** Front Protector Kit
2. **APPLICATION:** G Sedan Sports
3. **PART NUMBER:** K6010-1NH\*\* (XX Designates color)
4. **KIT CONTENTS:**

Item	Qty.	Description	Part Number
A	1	Front Chin Spoiler	---
B	2	BOLT Square Head	---
C	2	Washer(Rubber)	85274 AC015
D	2	NUT M6 Hexagon	-----
E	4	Push Pin	15-53 09321
F	1	Paper Template Sheet	---
G	1	Installation Instructions	---

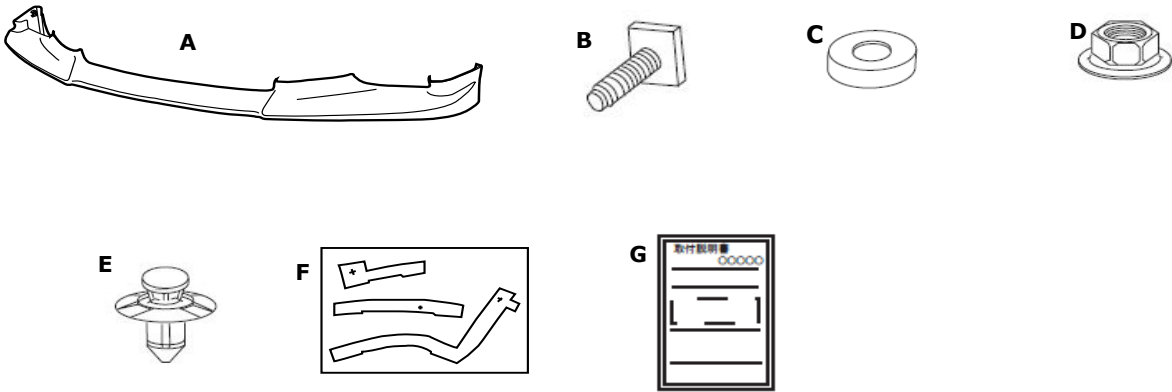

5. **TOOLS REQUIRED:**
  - Socket & Driver 10mm
  - Phillips head short screwdriver
  - Clip remover
  - (3mm (1/8"), 10mm (25/64"), and 8mm (5/16")) Drill Bit
  - Clean, Lint-Free Wiping Cloth
  - Center Punch
  - Drill
  - Masking Tape
  - 100% Alcohol
  - Scissors

6. **PRE-INSTALLATION CAUTIONS/NOTES:**

#### CAUTION

- Install the Front Chin Spoiler when the ambient temperature is above 60° F (15°C).
- Do not wash or expose the vehicle to a wet environment for 24 hours after installing the Front Chin spoiler.
- Installing this part concurrently with LED Daytime Driving Lights, please install LED Daytime Driving Lights first then install Front Chin-spoiler.  
LED Daytime Driving Lights cannot be installed if Front Chin-spoiler is installed first.

#### NOTE

- These instructions are for the left side of the vehicle; the same procedure applies to the right side.
- For the right side installation, use templates A and C with the text facing the vehicle.

# INSTALLATION INSTRUCTIONS - Front Chin Spoiler

## 7. INSTALLATION PROCEDURE:

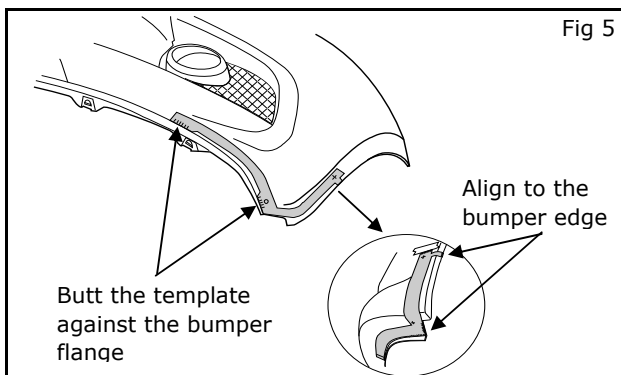
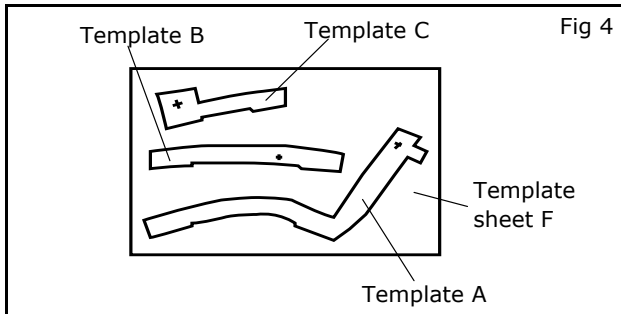
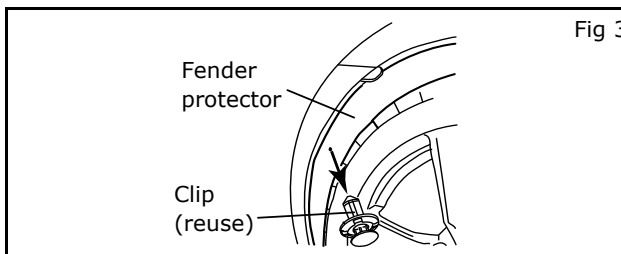
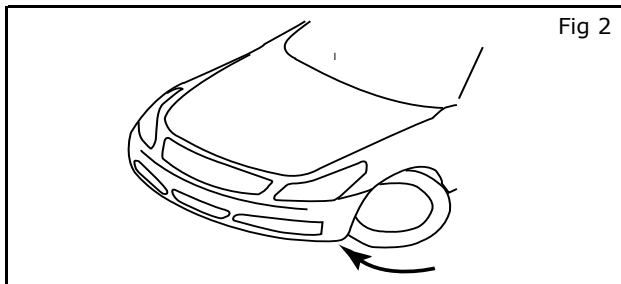
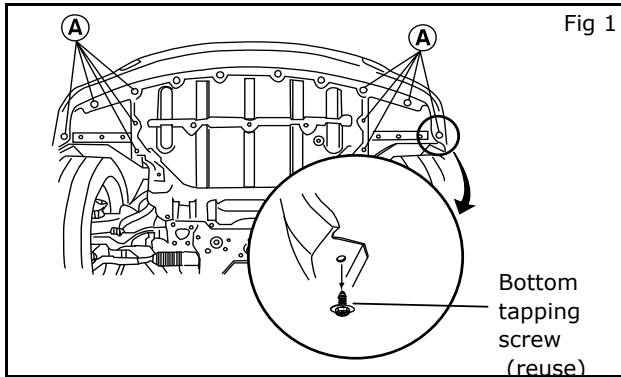

### 1. Installation preparation

- a) Jack up the vehicle using the instructions under the "Changing a Flat Tire" section of the owner's manual.
- b) Remove tapping screws(reuse) from under the vehicle. (5 on each side) See Fig. 1.
- c) Fully turn the steering wheel right or left to clear an area and easy to work around the front fender protector. See Fig. 2.
- d) Remove the clip(reuse) that attach the fender protector to the vehicle. (1 on each side) See Fig. 3.
- e) Cut paper templates A, B, and C from paper template sheet F, which is included in installation instruction G. See Fig. 4.
- f) Align template A (RH/LH) to lower front bumper by butting the template against the bumper flange. and apply masking tape to hold the template in place. See Fig. 5.

## INSTALLATION INSTRUCTIONS - Front Chin Spoiler

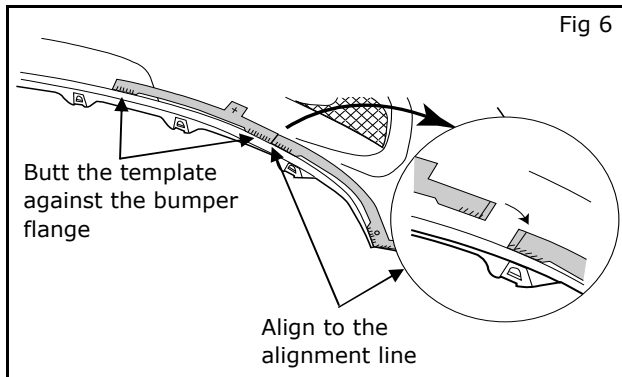

- g) Align template B (RH/LH) to lower front bumper by butting the template against the bumper flange. Align the edge of template B to the alignment line of template A. Apply masking tape to connect template A to template B. See Fig. 6.

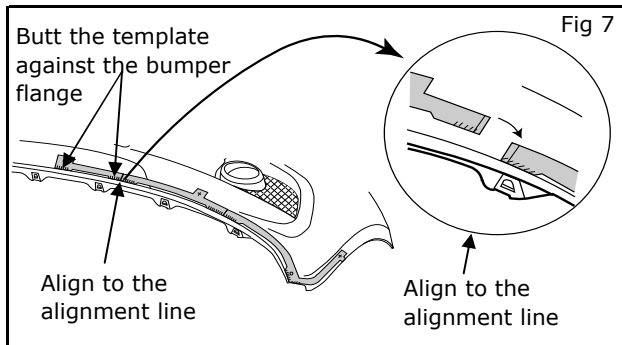

- h) Align template C (RH/LH) to lower front bumper by butting the template against the bumper flange. Align the edge of template C to the alignment line of template B. Apply masking tape to connect template B to template C. See Fig. 7.

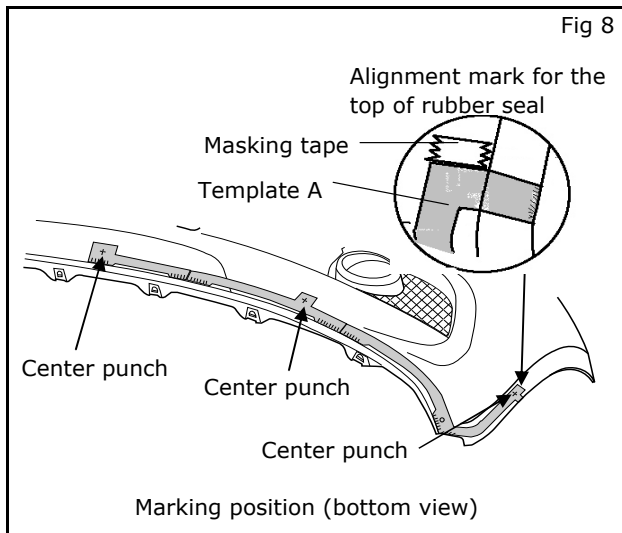

- i) Use masking tape to make an alignment mark line for the top of the rubber seal by aligning the bottom of a piece of masking tape to the top of template A. See Fig. 8.
- j) Mark the hole position (+) with center punch. See Fig. 6.
- k) Slowly remove template A,B and C together (reuse).

**NOTE:**  
**DO NOT REMOVE THE ALIGNMENT LINE MASKING TAPE. BE SURE NOT TO DAMAGE THE TEMPLATE DURING REMOVAL, AS IT WILL BE REQUIRED FOR RIGHT SIDE INSTALLATION.**

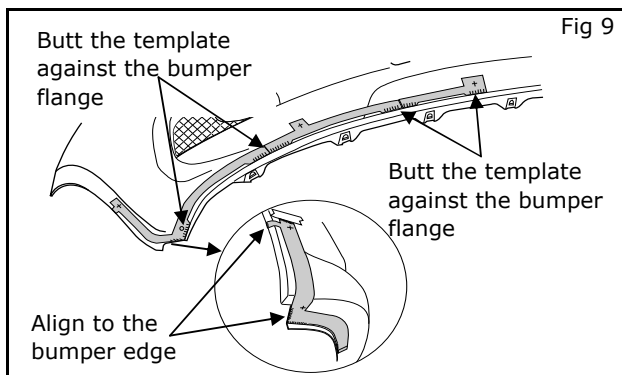

- l) Align template A , B and C to lower front bumper by butting the template against the bumper flange. and apply masking tape to hold the template in place. for right hand side. See Fig. 9.

## INSTALLATION INSTRUCTIONS - Front Chin Spoiler

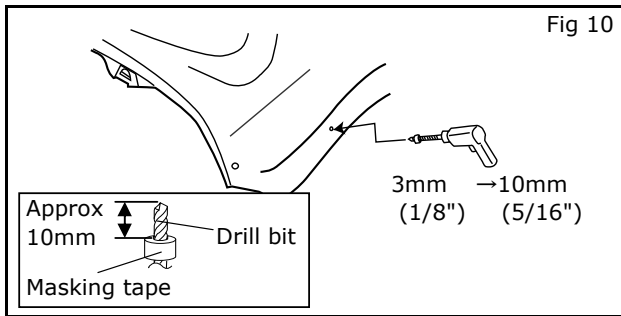

- m) Wrap masking tape around 3 mm (1/8"), 8 mm (5/16") and 10 mm (25/64") drill bits, approximately 10mm from the tip.
- n) Drill 3 mm (1/8") → 10 mm (25/64") holes at the marked locations on the front bumper. See Fig 10.

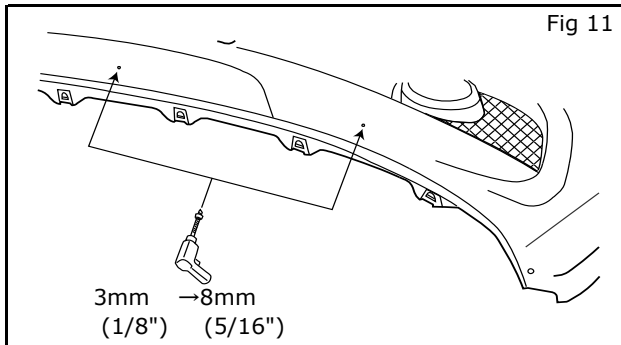

- o) Drill 3 mm (1/8") → 8 mm (5/16") holes at the marked locations on the front bumper. See Fig 11.

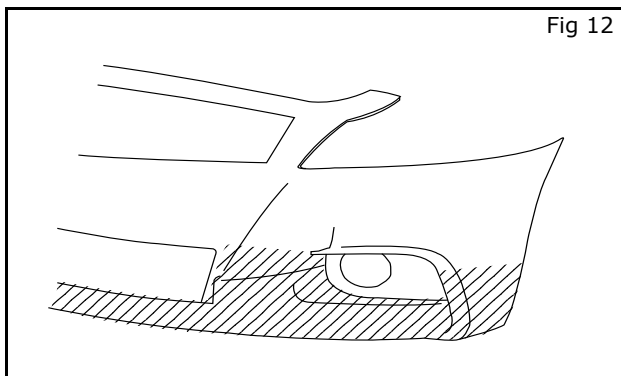

- p) Using a clean, lint free cloth and 100% alcohol, wipe any dirt and oil from the mounting surface. Let area dry thoroughly. See Fig. 12.

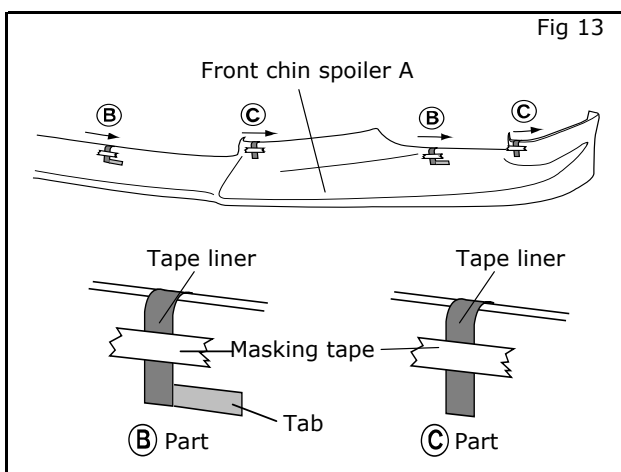

### 2. Front chin spoiler installation

- exclude part A (see stepC and fig. 13 )
- a) At B part of fig.13, Peel off about 30mm of the tape liner from the double-sided tape on the front chin spoiler A. in the direction shown by the arrow.
- b) At C part of fig.13, Pull tape liner on the front chin spoiler A. Don't peel off the tape liner from the double-sided tape.
- C) Fold the tape liner onto the front chin spoiler A painted surface and apply masking tape to ensure that the tape liner is accessible. (Total 8 locations) See Fig. 13.

# INSTALLATION INSTRUCTIONS - Front Chin Spoiler

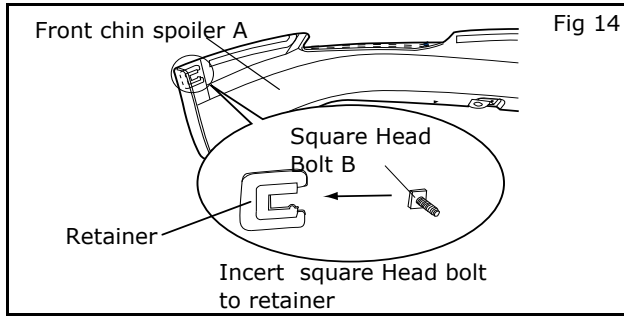

- d) Assemble square head bolt B to Chin spoiler A. See Fig. 14.

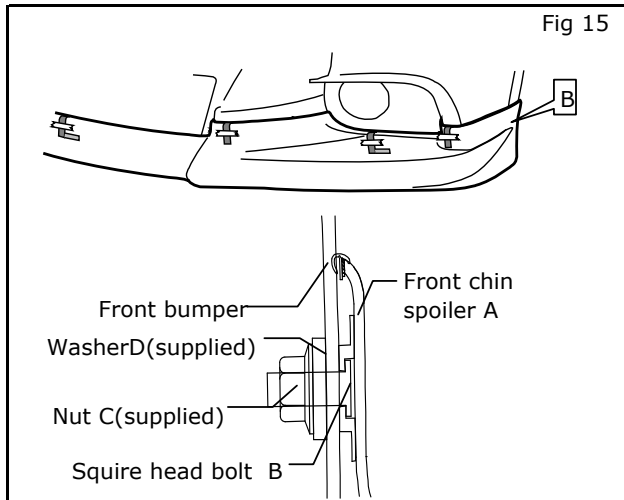

- e) Align the front chin spoiler A Square head bolt B to the drilled holes in the front bumper and push the front chin spoiler A against the front bumper to insert the square head bolt B in the holes.
- f) Loosely install the nuts C (supplied) and washer D (supplied) on the front chin spoiler A square head bolt B to ensure that the front chin spoiler A is attached. See Fig. 15.

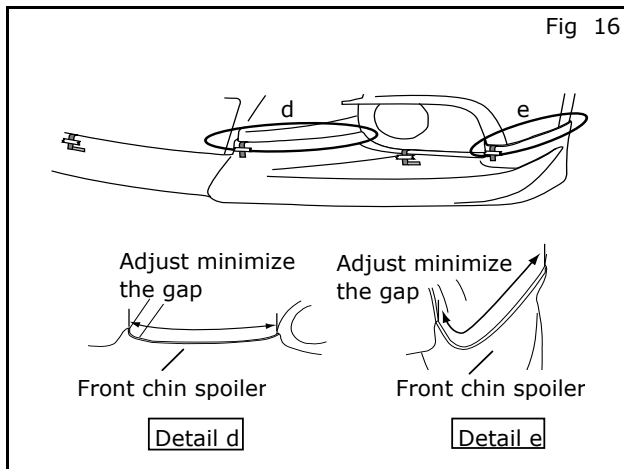

- g) Align and adjust the front chin spoiler A to the front bumper to minimize the gap. See Fig 16.

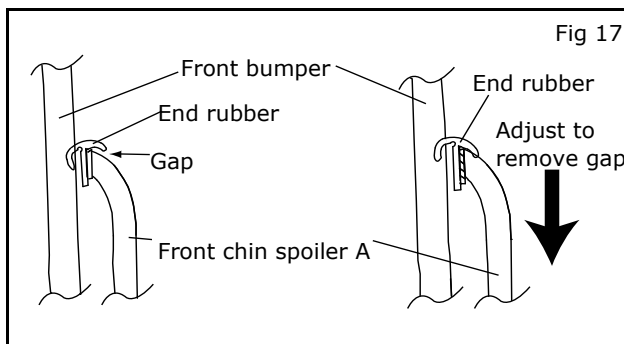

**Note:**  
**If gap occurred between end-rubber and surface of Chin spoiler A.**  
**Move Chin spoiler A below from the top and adjust.**

**See fig.17**

# INSTALLATION INSTRUCTIONS - Front Chin Spoiler

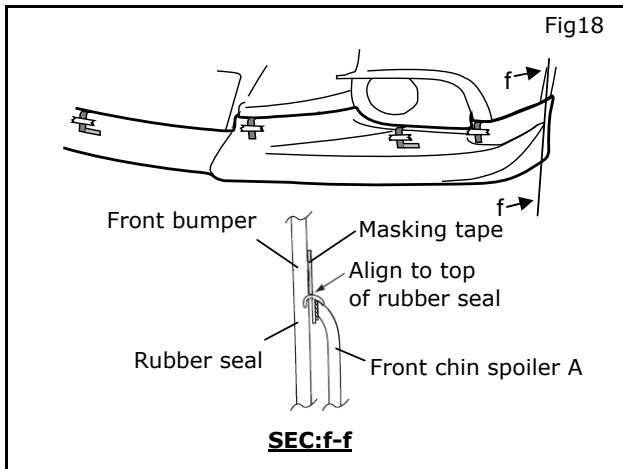

- h) Align top of the front chin spoiler A rubber seal to bottom of the masking tape. See Fig 18.

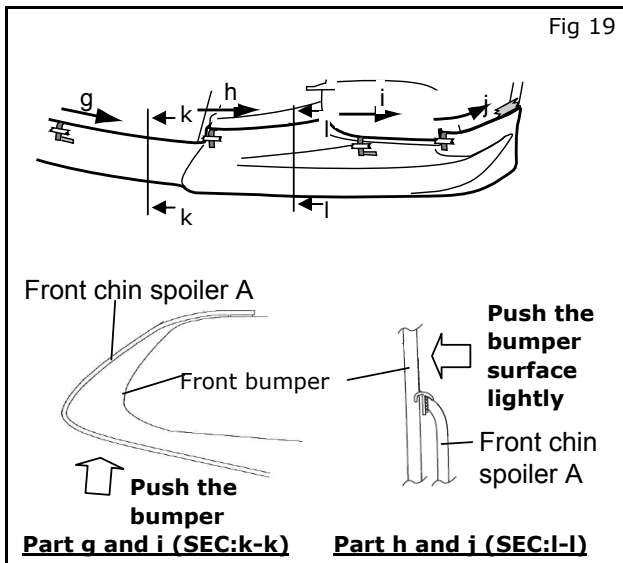

- i) Starting at the center and moving outward, remove the tape liner "g" through "j" and apply at least 15lbs. of pressure to the front chin spoiler A at part "g" through "k" to ensure that the front chin spoiler A is attached. See Fig. 19.

**NOTE:**  
**REMOVE TAPE LINER SLOWLY,**  
**If difficult to remove Tape-liner.**  
**Part g and i:**  
**Push up protector A lightly from the bottom**  
**Part h and j:**  
**Push the bumper surface lightly**  
**Pull tape liner after enlarging the gap**

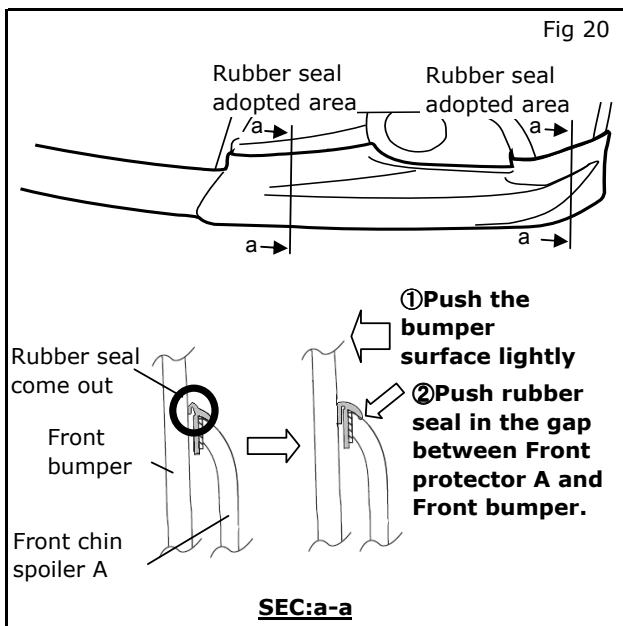

**NOTE:**  
**If rubber seal came out when pull tape-liner inside out,**  
**Please push rubber-seal between Front chin spoiler A and Front bumper with finger or soft rubber spatulas.**  
**See Fig. 20**

# INSTALLATION INSTRUCTIONS - Front Chin Spoiler

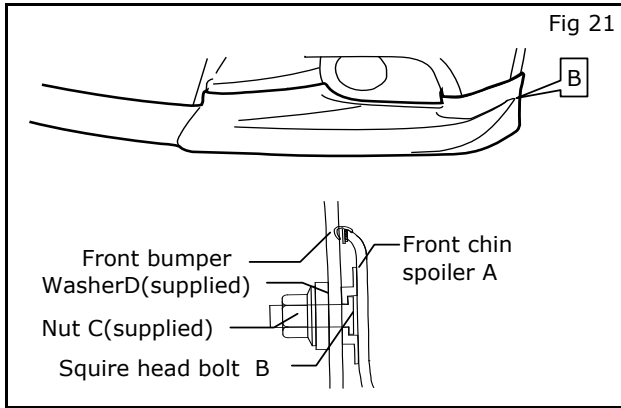

- j) Tighten nut C(supplied) in area B.  
See Fig 21.

TORQUE VALUE;  
**2~3Nm**

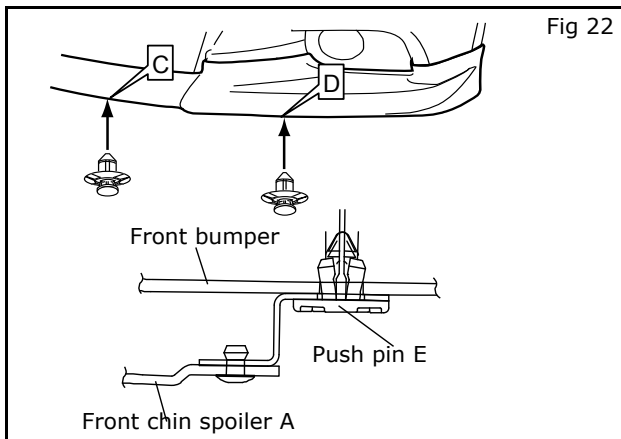

- k) Install push pin E(supplied) in areas C and D under the vehicle. See Fig. 22.

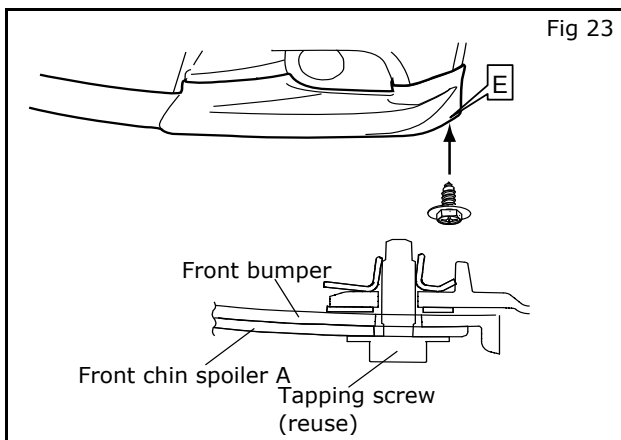

- l) Tighten Tapping screw (reuse) in areas E.  
See Fig 23.

TORQUE VALUE;  
**2~3Nm**

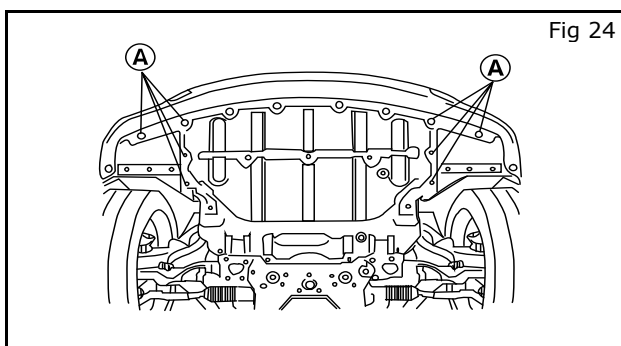

- m) Install tapping screws(reuse) from under the vehicle. (4 on each side) See Fig. 24.

## INSTALLATION INSTRUCTIONS - Front Chin Spoiler

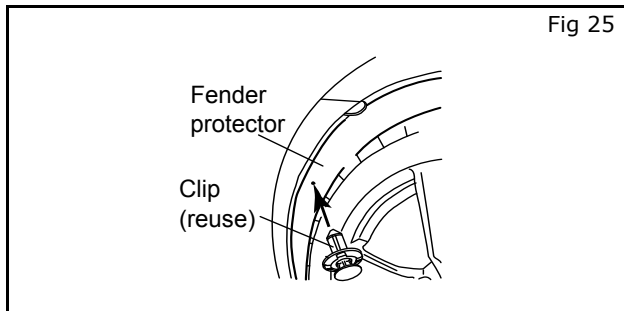

- n) Install the clip(reuse) that attach the fender protector to the vehicle. (1 on each side) See Fig. 25.