



INFINITI.

GENUINE PARTS

INSTALLATION INSTRUCTIONS

1. **DESCRIPTION:** Front Protector Kit
2. **APPLICATION:** G Sedan
3. **PART NUMBER:** K6010-1NF** (XX Designates color)
4. **KIT CONTENTS:**

Item	Qty.	Description	Part Number
A	1	Front Chin Spoiler	---
B	2	BOLT Square Head	-----
C	2	Washer(Rubber)	85274 AC015
D	2	NUT M6 Hexagon	-----
E	2	Tapping Screw Truss Head M5×15mm	14-51 00841
F	2	Spring Clip M5 (Large)	12-41 00911
G	2	Push Pin (A ;Short)	15-53 09321
H	2	Push Pin(B ;Long)	-----
I	1	Paper Template Sheet	---
J	1	Installation Instructions	---

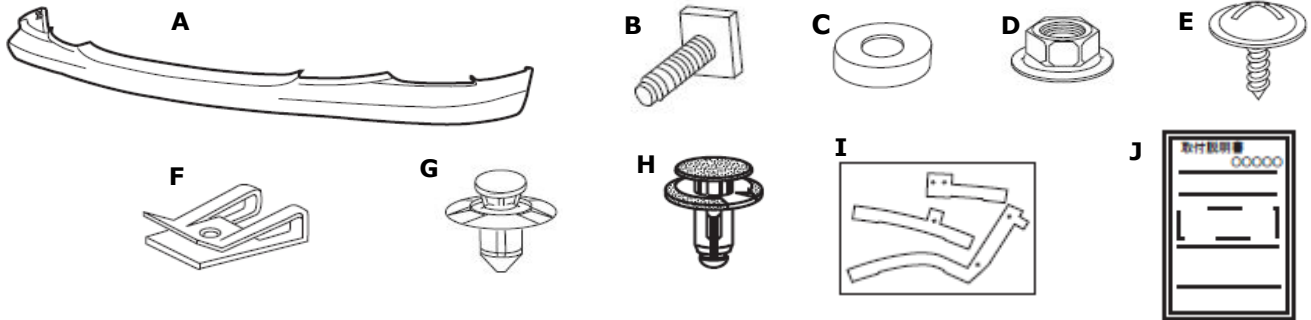

5. **TOOLS REQUIRED:**
 - Socket & Driver 10mm
 - Phillips head short screwdriver
 - Clip remover
 - Clean, Lint-Free Wiping Cloth
 - 25mm (1") Hole Saw
 - Center Punch
 - Drill
 - (3mm (1/8"), 10mm (25/64"), and 8mm (5/16")) Drill Bit
 - Masking Tape
 - 100% Alcohol
 - Scissors

6. **PRE-INSTALLATION CAUTIONS/NOTES:**

⚠ CAUTION

- Install the Front Chin Spoiler when the ambient temperature is above 60° F (15°C).
- Do not wash or expose the vehicle to a wet environment for 24 hours after installing the Front Chin spoiler.

NOTE

- These instructions are for the left side of the vehicle; the same procedure applies to the right side.
- For the right side installation, use templates A and C with the text facing the vehicle.

INSTALLATION INSTRUCTIONS - Front Chin Spoiler

7. INSTALLATION PROCEDURE:

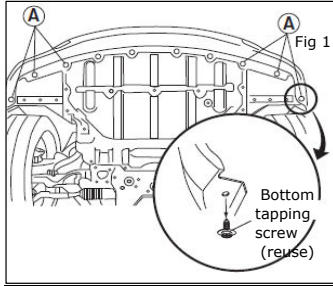

1. Installation preparation

- a) Jack up the vehicle using the instructions under the "Changing a Flat Tire" section of the owner's manual.
- b) Remove tapping screws(reuse) from under the vehicle. (3 on each side) See Fig. 1.

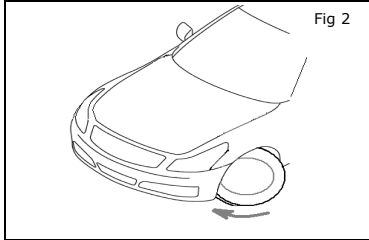

- c) Fully turn the steering wheel right or left to clear an area and easy to work around the front fender protector. Fig. 2.

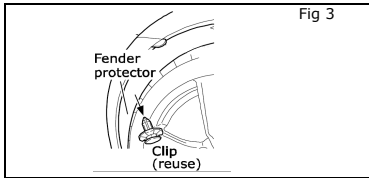

- d) Remove the clip(reuse) that attach the fender protector to the vehicle. (1 on each side) See Fig. 3.

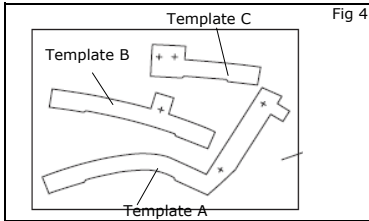

- e) Cutting paper template sheet H
Cut paper templates A, B, and C from paper template sheet H, which is included in installation instruction J. See Fig. 4.

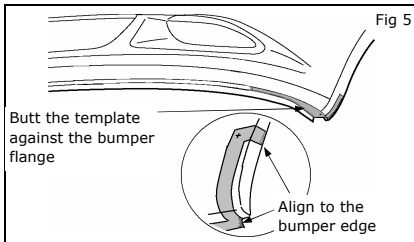

- f) Align template A (RH/LH) to lower front bumper by butting the template against the bumper flange. and apply masking tape to hold the template in place. See Fig. 5.

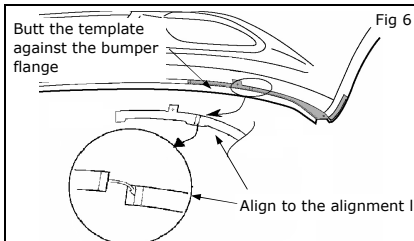

- g) Align template B (RH/LH) to lower front bumper by butting the template against the bumper flange. Align the edge of template B to the alignment line of template A. Apply masking tape to connect template A to template B. See Fig. 6.

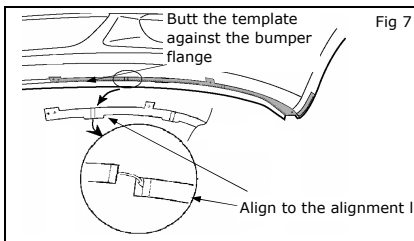

- h) Align template C (RH/LH) to lower front bumper by butting the template against the bumper flange. Align the edge of template C to the alignment line of template B. Apply masking tape to connect template B to template C. See Fig. 7.

INSTALLATION INSTRUCTIONS - Front Chin Spoiler

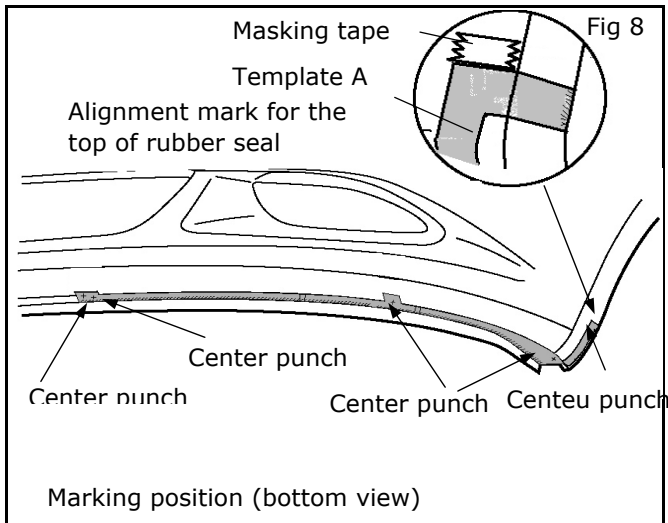

- i) Use masking tape to make an alignment mark line for the top of the rubber seal by aligning the bottom of a piece of masking tape to the top of template A. See Fig 8.
- j) Mark the hole position (+) with center punch. See Fig. 6.
- k) Slowly remove template A,B and C together (reuse).

NOTE:
DO NOT REMOVE THE ALIGNMENT LINE MASKING TAPE. BE SURE NOT TO DAMAGE THE TEMPLATE DURING REMOVAL, AS IT WILL BE REQUIRED FOR RIGHT SIDE INSTALLATION.

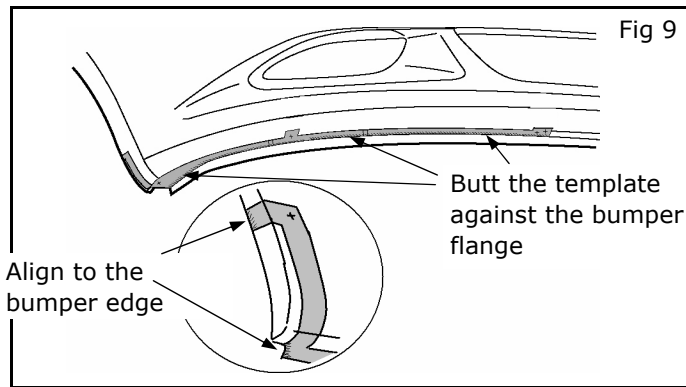

- l) Align template A , B and C to lower front bumper by butting the template against the bumper flange. and apply masking tape to hold the template in place. for right hand side. See Fig. 9.

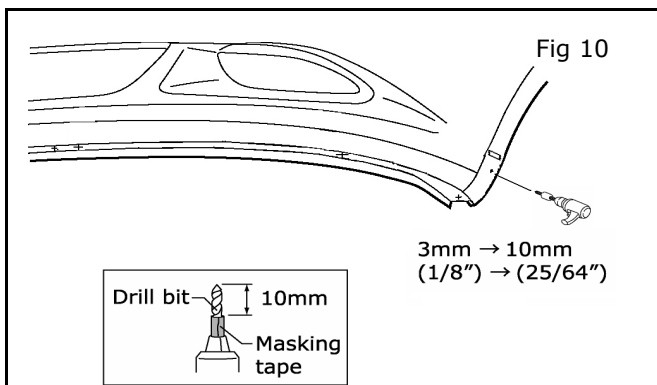

- m) Wrap masking tape around 3 mm (1/8"), 8 mm (5/16") and 10 mm (25/64") drill bits, approximately 10mm from the tip.
- n) Drill 3 mm (1/8") → 10 mm (25/64") holes at the marked locations on the front bumper. See Fig 10.

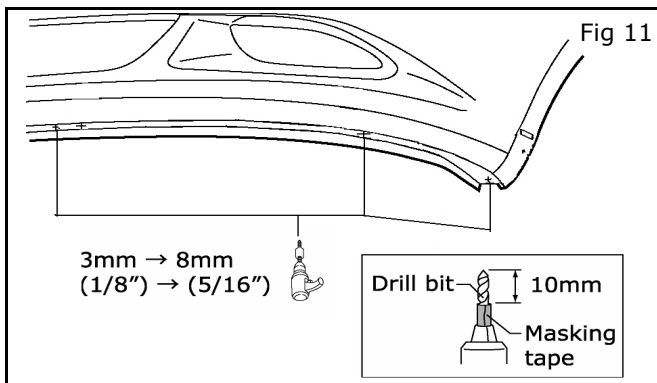

- o) Drill 3 mm (1/8") → 8 mm (5/16") holes at the marked locations on the front bumper. See Fig 11.

INSTALLATION INSTRUCTIONS - Front Chin Spoiler

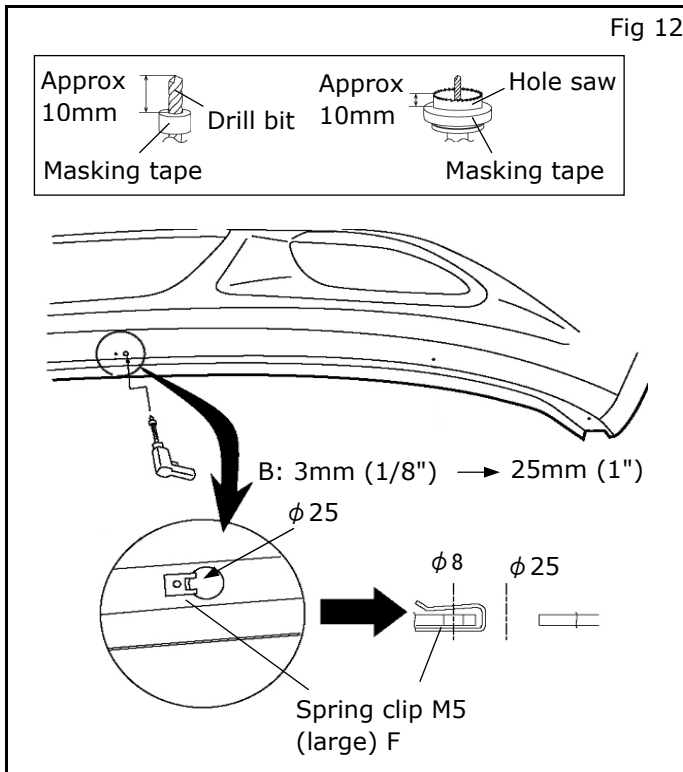

- p) Drill 3 mm (1/8") → 25 mm (1") holes at the marked locations on the front bumper. See Fig 12.

NOTE:
Check spring clip M5(large) F for correct installation direction.

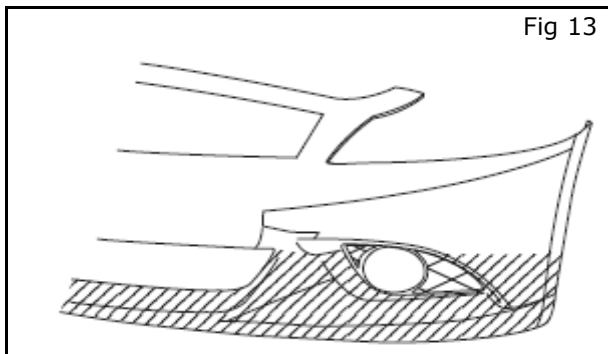

- q) Using a clean, lint free cloth and 100% alcohol, wipe any dirt and oil from the mounting surface. Let area dry thoroughly. See Fig. 13.

INSTALLATION INSTRUCTIONS - Front Chin Spoiler

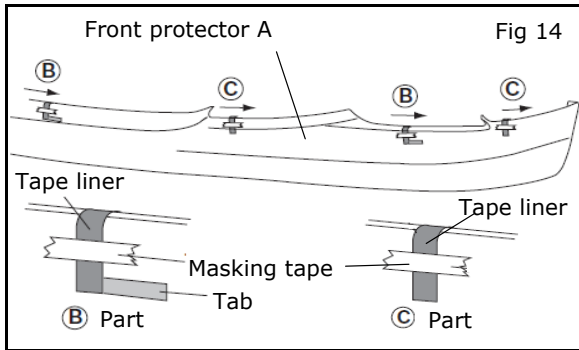

2. Front chin spoiler installation

exclude part A (see step C and fig. 15)

- a) At B part of fig.14, Peel off about 30mm of the tape liner from the double-sided tape on the front chin spoiler A.
in the direction shown by the arrow.
- b) At C part of fig.14, Pull tape liner on the front chin spoiler A.
Don't peel off the tape liner from the double-sided tape.
- C) Fold the tape liner onto the front chin spoiler A painted surface and apply masking tape to ensure that the tape liner is accessible.
(Total 8 locations) See Fig. 14.

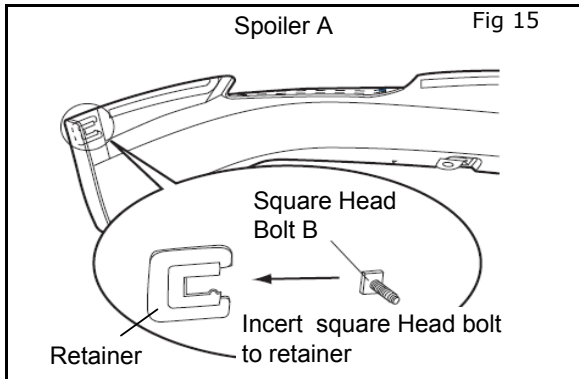

- d) Assemble squarehead bolt B to Chin spoiler A.
See Fig. 15.

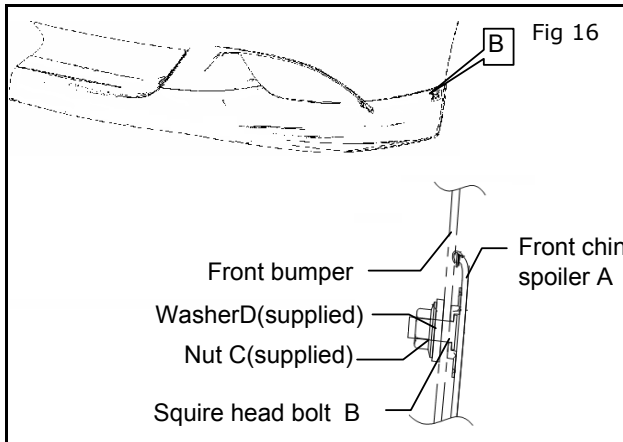

- e) Align the front chin spoiler A Square head bolt B to the drilled holes in the front bumper and
push the front chin spoiler A against the front bumper to insert the squarehead bolt B in the holes.
- f) Loosely install the nuts C (supplied) and washer D (supplied) on the front chin spoiler A tapping screws B to ensure that the front chin spoiler A is attached.
See Fig. 16.

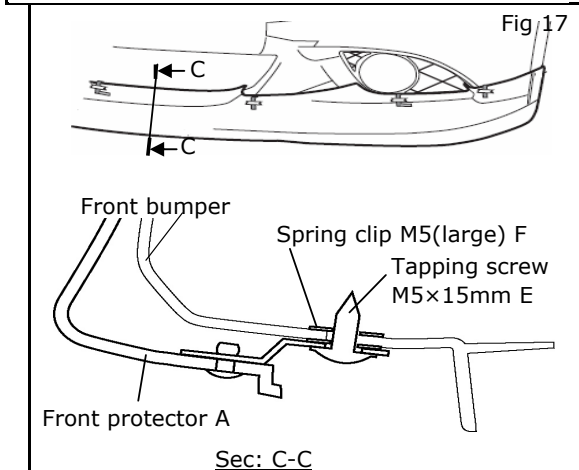

- g) Loosely install the tapping screw M5 X 15mm E (supplied) underneath the front chin spoiler
See Fig 17.

INSTALLATION INSTRUCTIONS - Front Chin Spoiler

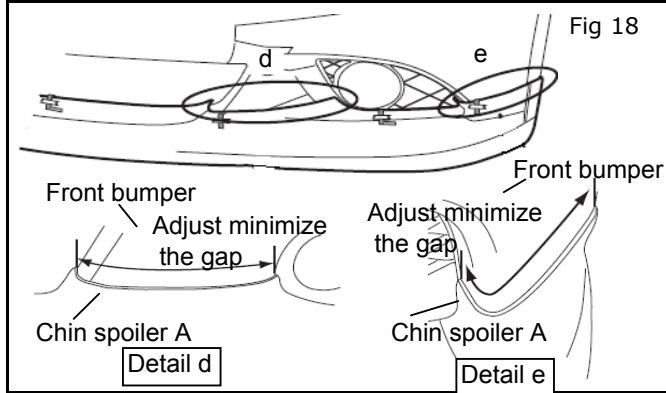

- h) Align and adjust the front chin spoiler A to the front bumper to minimize the gap

See Fig 18.

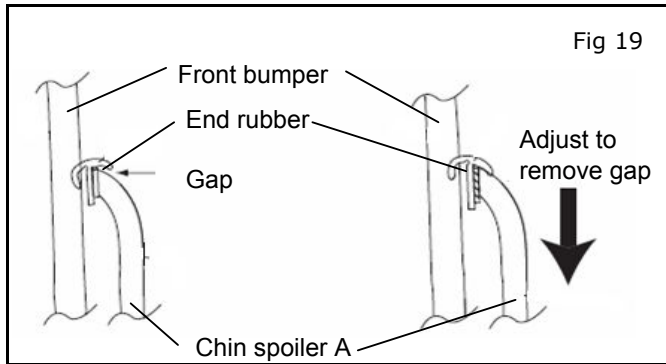

Note:

If gap occurred between end-rubber and surface of Chin spoiler A.

Move Chin spoiler A below from the top and adjust.

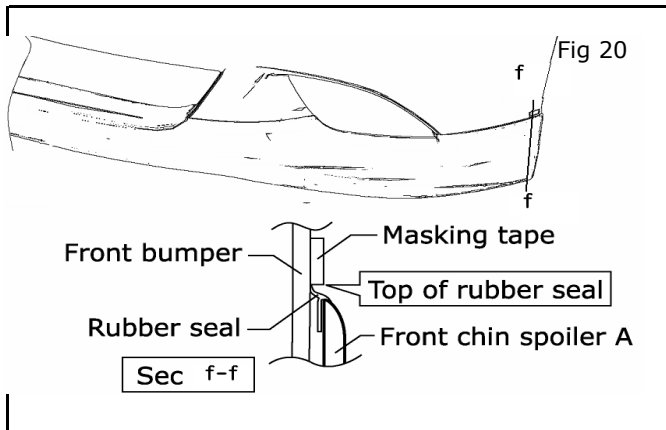

- i) Align top of the front chin spoiler A rubber seal to bottom of the masking tape. See Fig 20.

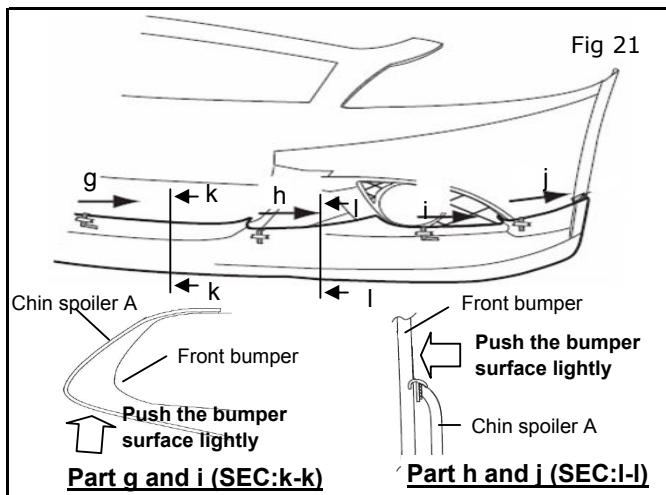

- j) Starting at the center and moving outward, remove the tape liner "g" through "j" and apply at least 15lbs. of pressure to the front chin spoiler A at part of "g" through "k" to ensure that the front chin spoiler A is attached. See Fig. 21.

NOTE:

REMOVE TAPE LINER SLOWLY, If difficult to remove Tape-liner.

Part g and i:
Push up Chin spoiler A lightly from the bottom

Part h and j:
Push the bumper surface lightly
Pull tape liner after enlarging the gap

Part h and j:

INSTALLATION INSTRUCTIONS - Front Chin Spoiler

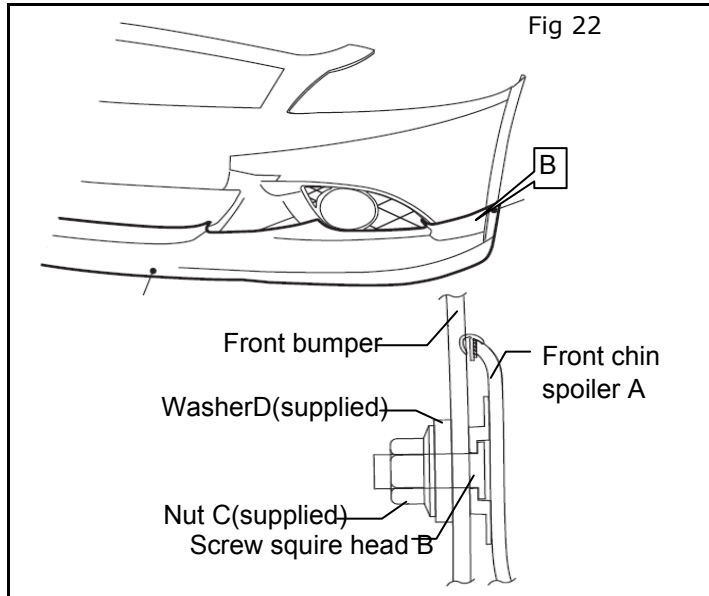

- k) Tighten nut C(supplied) in area B.
See Fig 22.

TORQUE VALUE;
2~3Nm

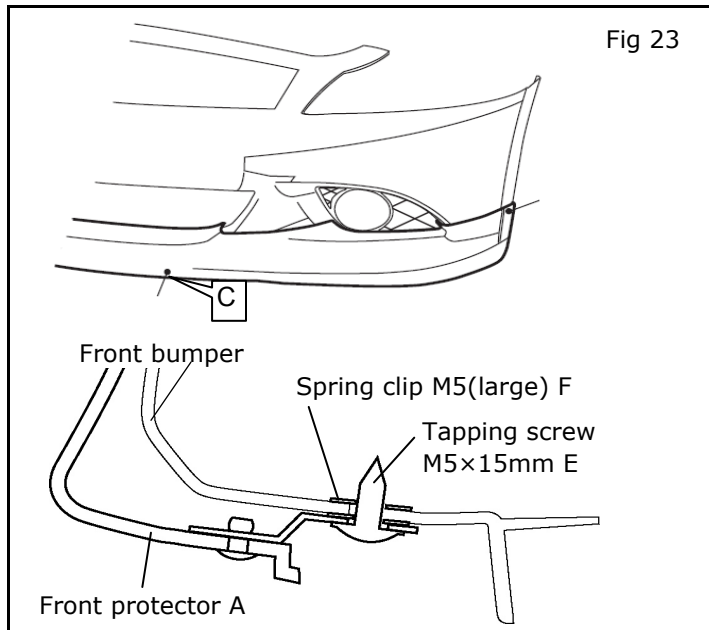

- l) Tighten Tapping screw E(supplied) in area C.
See Fig 23.

TORQUE VALUE;
1~1.5Nm

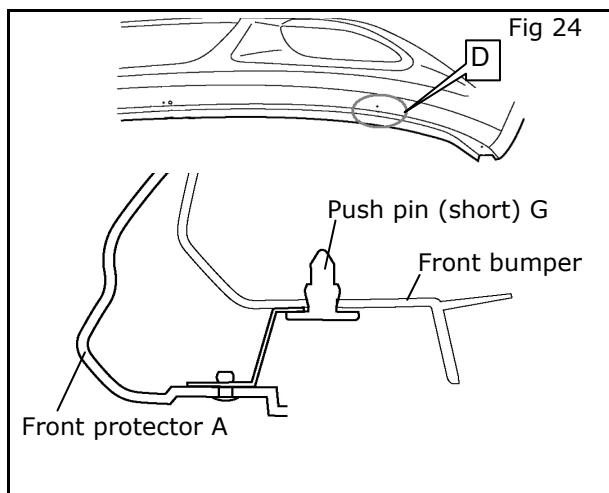

- m) Install push pin G(supplied) in areas D
under the vehicle. See Fig. 24.

INSTALLATION INSTRUCTIONS - Front Chin Spoiler

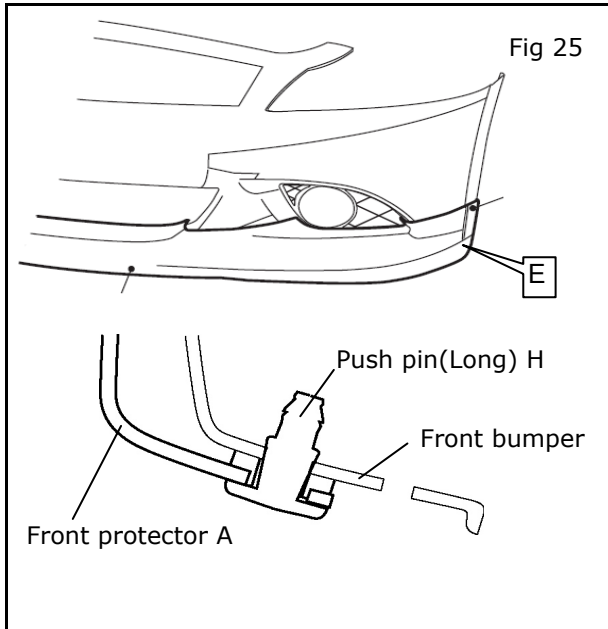

- n) Install push pin H(supplied) in areas E under the vehicle. See Fig. 25.

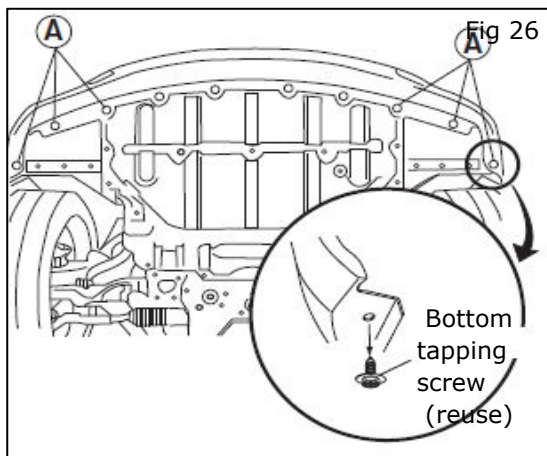

- o) Install tapping screws(reuse) from under the vehicle. (3 on each side) See Fig. 26.

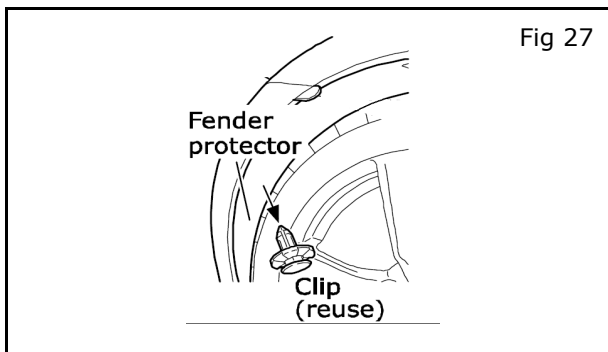

- p) Install the clip(reuse) that attach the fender protector to the vehicle. (1 on each side) See Fig. 27.