



GENUINE PARTS

INSTALLATION INSTRUCTIONS

DESCRIPTION: REAR SPOILER
APPLICATION: Q70
PART NUMBER: 999J1 QXxxx (xxx Designates color)

KIT CONTENTS:

Item	Qty.	Description	Service Part Number
A	1	Rear Spoiler	---
B	2	Bolt Stud - M5	---
C	2	Nut - M5	---
D	2	Rubber Washer with double faced tape	---
E	2	Clip	---
F	2	Grommet	---
G	1	Template - D [LH]	---
H	1	Template - E [RH]	---
I	1	Installation Instructions Replacement Template	---

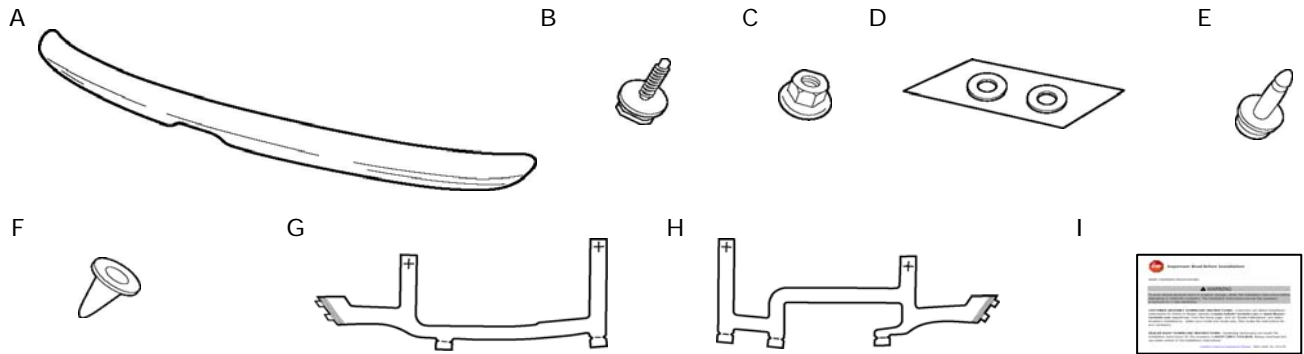

TOOLS REQUIRED:

- Deep Socket & driver 10 mm (25/64")
- Drill
- Deburring tool
- Air compressor & blow gun
- Clean, lint-free wiping cloth
- Torque wrench
- 3mm (1/8"), 8mm (5/16") Drill bit
- Masking tape
- 90% or greater alcohol
- Rust preventative(P/N 999MP-9G001P)
- Clip remover
- Center Punch/Awl
- Drop Cloth
- Small ruler

PRE-INSTALLATION WARNING, CAUTIONS CRITICAL STEPS, and NOTES:

- Dealer installation Recommended.

CAUTION

- Install the Rear spoiler when the ambient temperature is above 60°F (15°C).
- Do not wash or expose the vehicle to a wet environment for 24 hours after installing the Rear Spoiler.

INSTALLATION PROCEDURE:

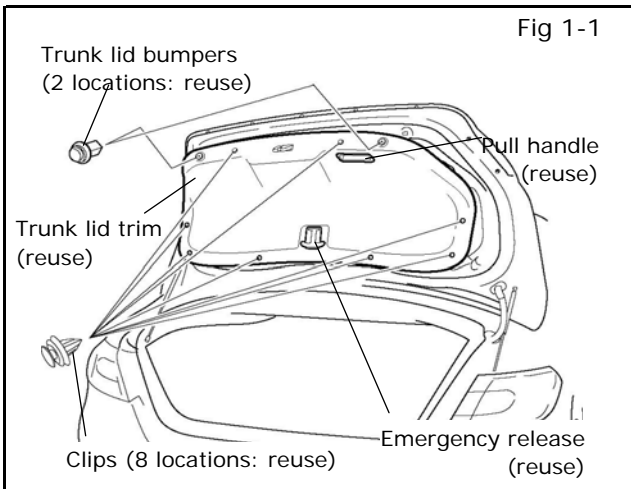

Fig 1-1

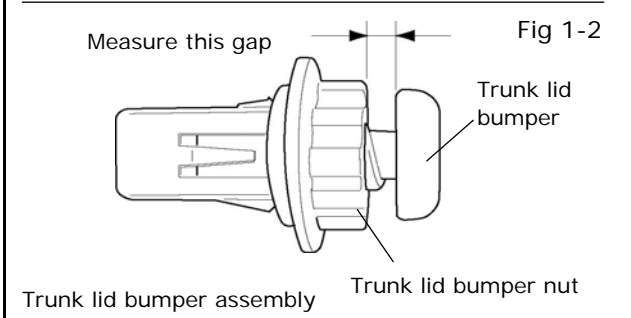

Fig 1-2

- 1) Open vehicle trunk lid and find the trunk lid bumper assemblies (RH/LH: 1 location each). See Fig.1-1.
- 2) Use a small ruler to measure the gap between the bottom of the trunk lid bumper and the top of the trunk lid bumper nut (RH/LH: 1 location each). See Fig.1-2.

Write down measured dimensions in the following table.

Trunk lid bumper gap	
RH	LH
mm	mm

- 3) Remove inner trim clips (8 locations; reuse), trunk lid bumper assembly (2 locations; reuse), Emergency release (1 location; reuse) and detach pull handle(1 location; reuse) from trunk lid with a clip remover. See Fig.1-1.
- 4) Remove the trunk lid trim.

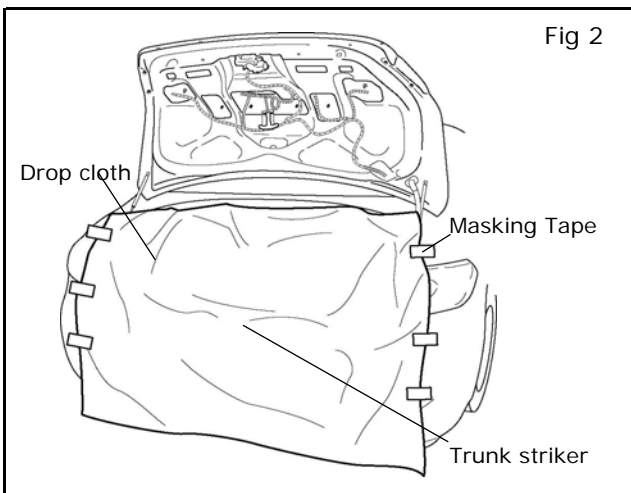

Fig 2

- 5) Attach the drop cloth to the trunk opening with masking tape. See. Fig 2.

NOTE:

Be sure to cover the trunk striker with the drop cloth.

- 6) Pull deck lid down.

INSTALLATION PROCEDURE:

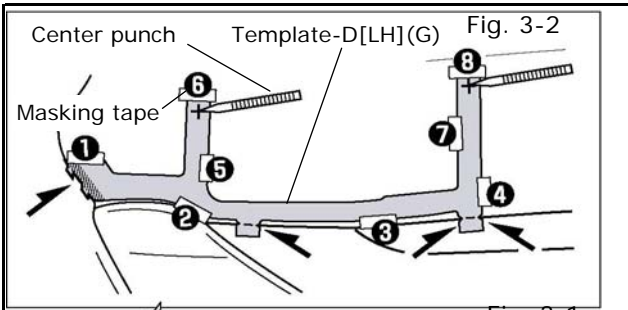

7) Align template-D[LH](G) to the edge of the trunk lid and apply masking tape, in sequence 1 - 8, to hold the template in place.
See Fig.3-1, Fig.3-2, Fig.3-3, Fig.3-4.

8) Mark the hole position ((+); 2 locations) with center punch.
Remove masking tape and template-D[LH](G).
See Fig.3-2.

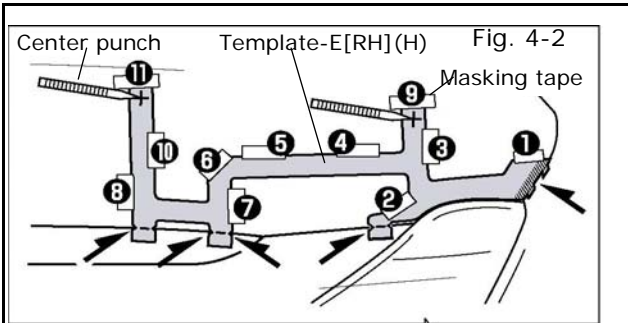
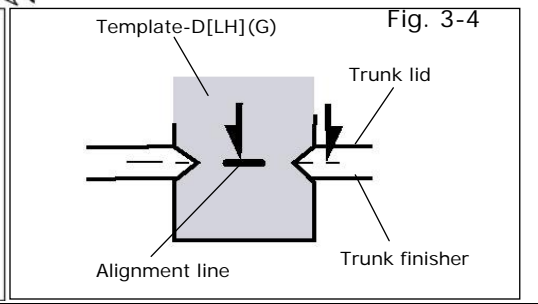
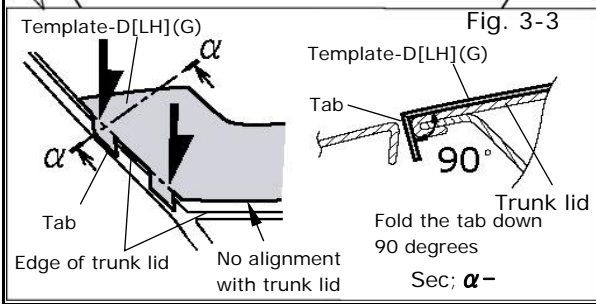
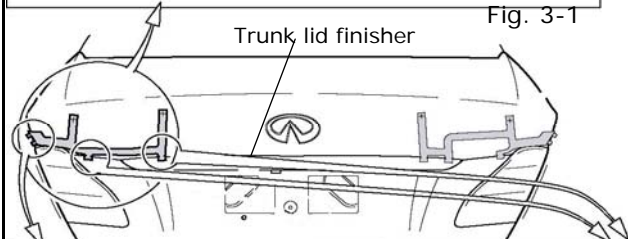

9) Align template-E[RH](H) to the edge of the trunk lid and apply masking tape, in sequence 1 - 11, to hold the template in place.
See Fig.4-1, Fig.4-2, Fig.4-3, Fig.4-4.

10) Mark the hole position ((+); 2 locations) with center punch.
Remove masking tape and template-E[RH](H).
See Fig.4-2.

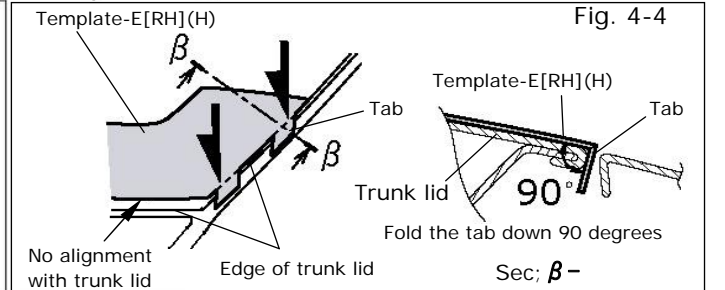
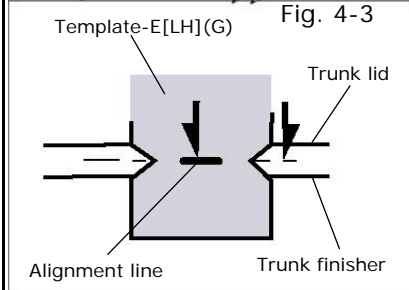
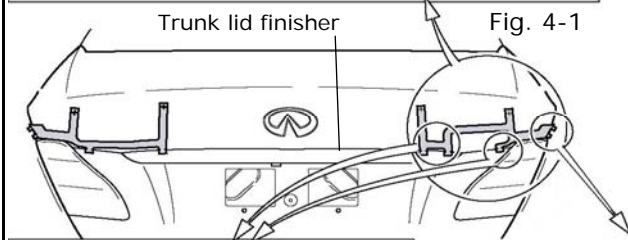

INSTALLATION PROCEDURE:

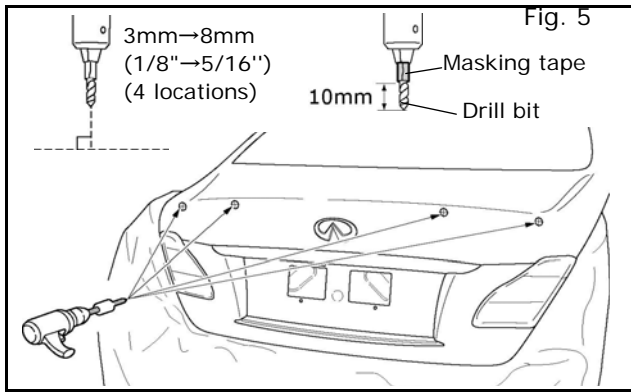

- 11) Wrap masking tape around 3mm (1/8"), and 8mm (5/16") drill bits, approximately 10mm from the tip.
See Fig.5.
- 12) Drill 3mm (1/8") → 8mm (5/16") holes at the 4 marked locations on the trunk lid.
See Fig.5.
- 13) Remove any sharp edges from the drilled holes with a deburring tool.

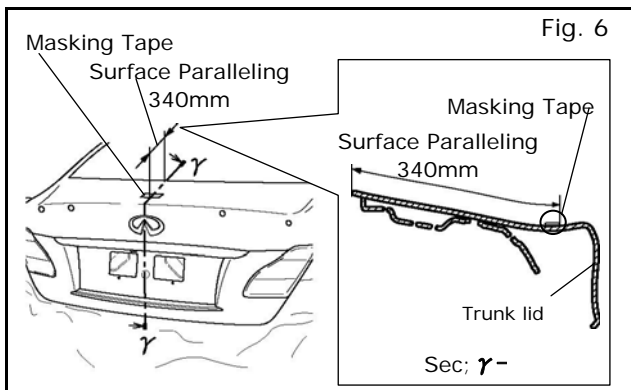

- 14) Mark the position at 340mm along surface of deck lid with a masking tape in a center part of the trunk lid.
See Fig.6.

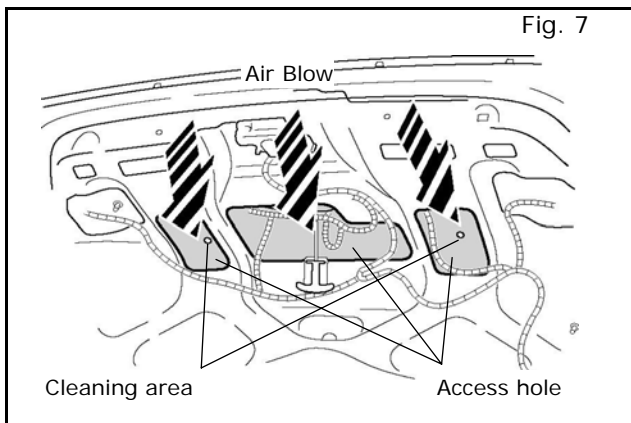

- 15) Open deck lid.
- 16) Remove metal shavings from inside trunk lid with the air compressor and blowgun.
See Fig.7.
- 17) Apply rust preventative (P/N 999MP 9G001P) to the drilled holes. Let area dry thoroughly.
See Fig.7.

CAUTION

- FAILURE TO APPLY RUST PREVENTATIVE WILL RESULT IN RED RUST.

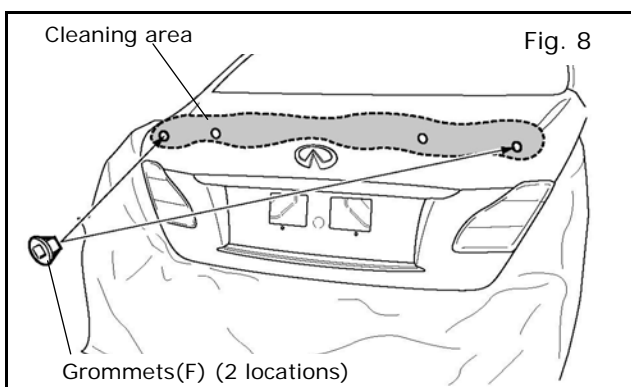

- 18) Pull deck lid down.
- 19) Attach grommets(F; supplied) to trunk lid (2 locations).
See Fig.8.
- 20) Using a clean, lint free cloth and 90% or greater alcohol, wipe any dirt and oil from the mounting surface. Let area dry thoroughly.
See Fig.8.

INSTALLATION PROCEDURE:

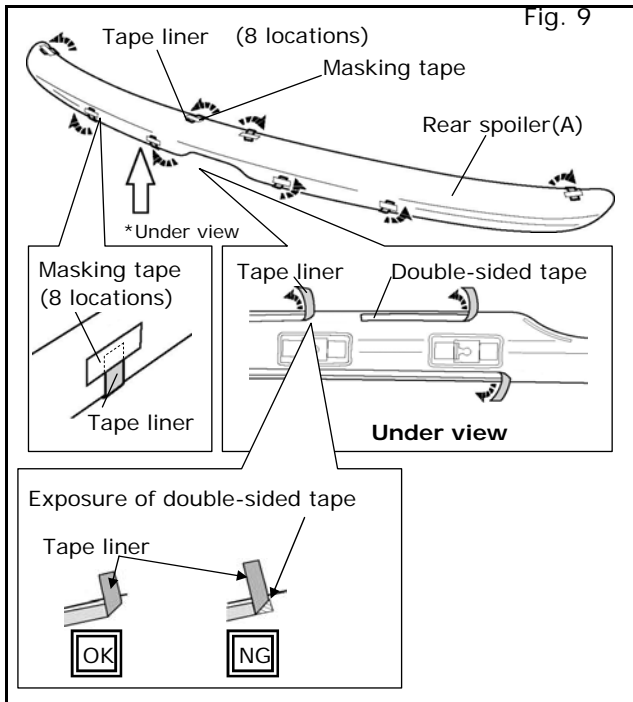

- 21) Turn tape liner on the surface of rear spoiler (A) in direction shown by arrow. See Fig. 9.
- 22) Fold tape liner onto rear spoiler(A) surface and apply masking tape to ensure that tape liner is accessible. See Fig. 9.

NOTE:

No tape should be exposed when wrapping and taping the liner pull tabs down.

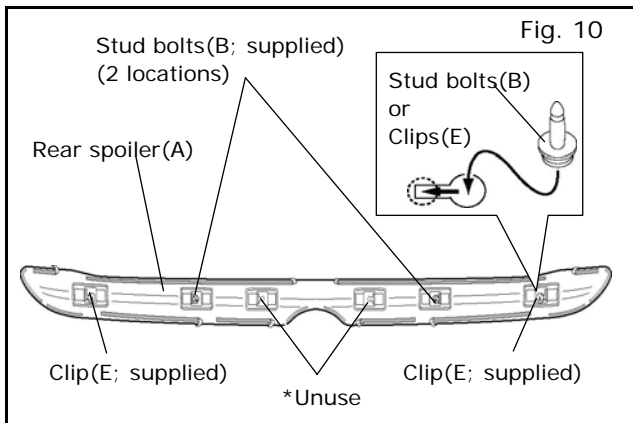

- 23) Assemble the clips(E; supplied) and stud bolts (B; supplied) to the rear spoiler. See Fig. 10.

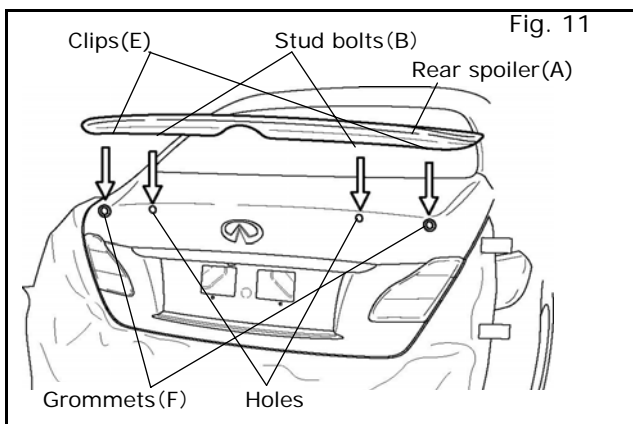

- 24) Align the rear spoiler bolts and clips to the drilled holes and grommets in the trunk lid and engaged rear spoiler (A) clips(E) to the trunk lid. See Fig. 11.

INSTALLATION PROCEDURE:

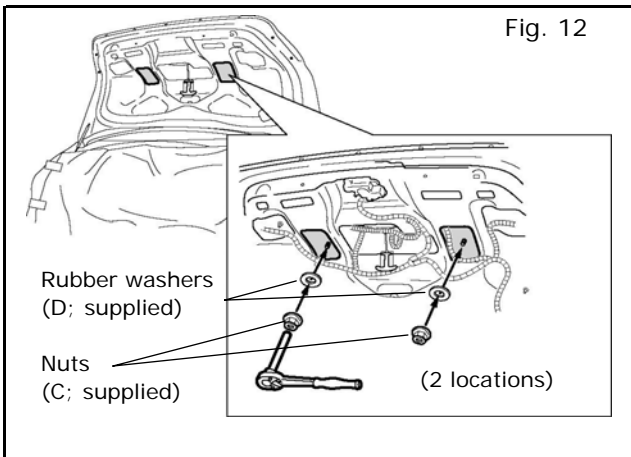

- 25) Open deck lid.
- 26) Attach rubber washers(D; supplied) on the inside of the trunk lid around the stud. (2 locations). See Fig.12.
- 27) Loosely install nuts(C; supplied) on the stud. See Fig.12.
- 28) Pull deck lid down.

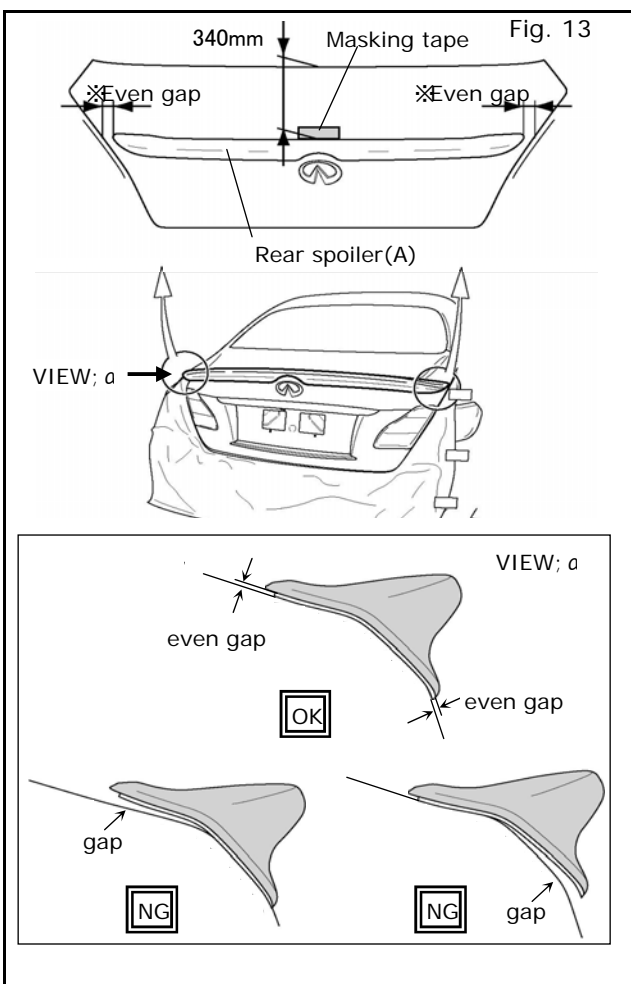

- 29) Center the rear spoiler on the trunk lid measure to ensure even gap at both ends. See Fig.13.
- 30) Align the front edge of rear spoiler to the position of the masking tape. See Fig.13.
- 31) Look at both side edges to ensure an even gap. See Fig.13.

INSTALLATION PROCEDURE:

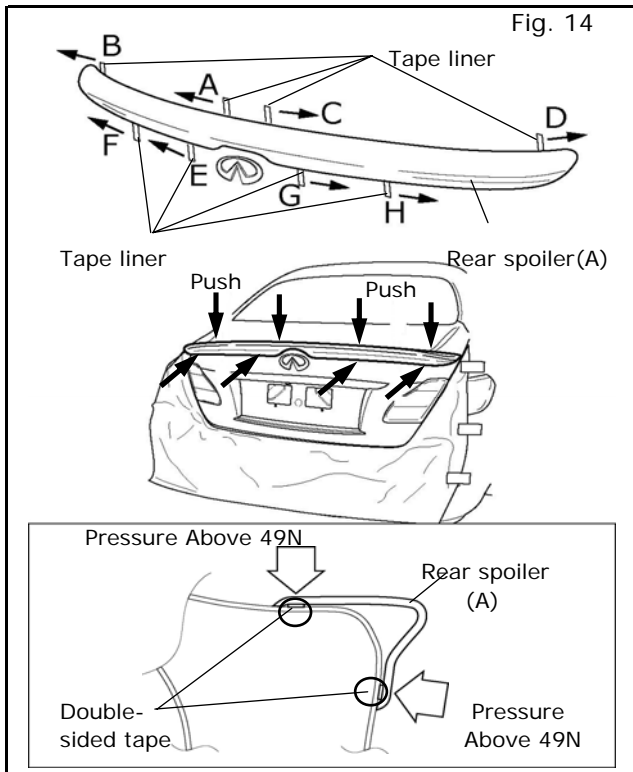

- 32) Remove tape liner A and B. And apply 15lbs. of pressure 3 times from center to outward.
- 33) Remove tape liner C and D. And apply 15lbs. of pressure 3 times from center to outward.
- 34) Remove tape liner E and F. And apply 15lbs. of pressure 3 times from center to outward.
- 35) Remove tape liner G and H. And apply 15lbs. of pressure 3 times from center to outward.
- 36) Apply at least 15lbs. of pressure to the rear spoiler to ensure that the rear spoiler is attached. See Fig.14.

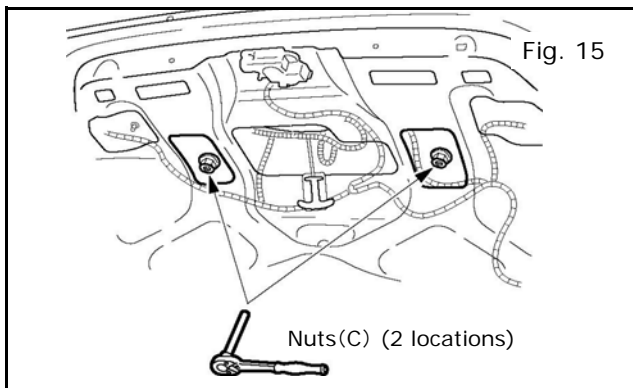

- 37) Open deck lid.
- 38) Tighten nuts(C) on the stud of the trunk lid.(2 locations) See Fig.15.

NOTE:

Tightening Torque: 5.6 - 7.4 N

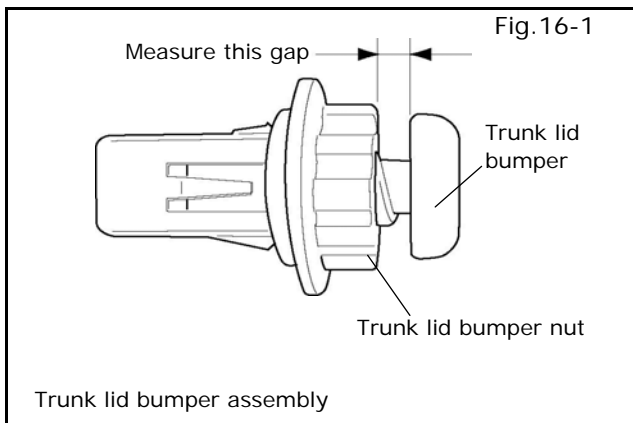

- 39) Adjust the trunk lid bumper assembly by turning the trunk lid bumper nut clockwise until the gap between the bottom of the trunk lid bumper and the top of the trunk lid bumper nut matches the gap measured in 1.Installation preparation (b). See Fig.16-1

INSTALLATION PROCEDURE:

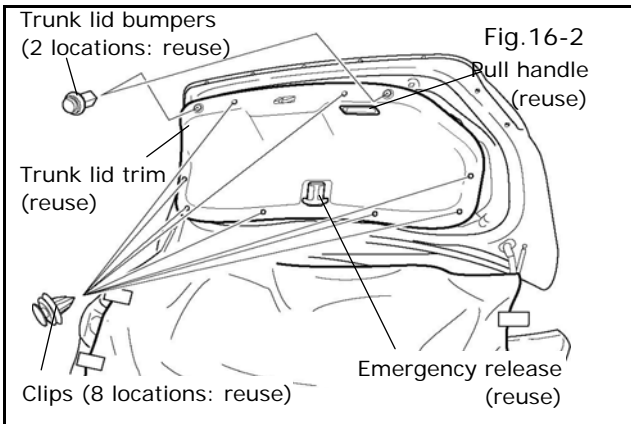

- 40) Reinstall all parts that were labeled reuse, using the reverse of the removal process. See Fig.16-2.
- 41) Pull deck lid down.
- 42) Remove masking tape.

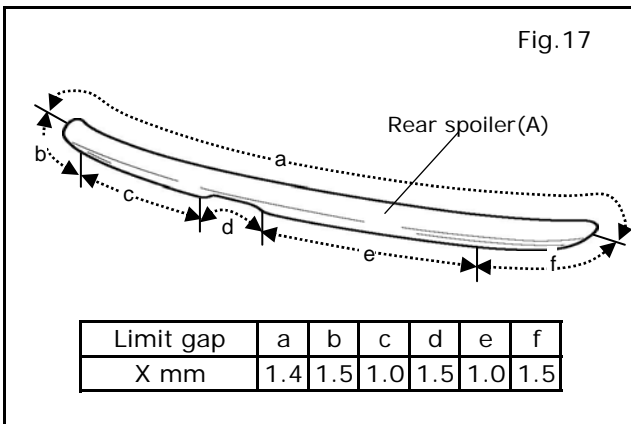

ACCESSORY CHECK:

- Please check that installation has no problem.
- Check gap. See Fig.17.

REINSTALLATION OF REMOVED PARTS

- Re-install all removed vehicle parts. Refer to the vehicle service manual for more details.
- Clean trunk opening of vehicle.

FINAL INSPECTION:

- Verify re-installed trim parts for proper flush fit
- Verify all clips are fully engaged and locked.
- Verify re-installed trim parts are free from cracks, scratches or stress marks.

VEHICLE CHECK

- Remove all tools from vehicle.