

INSTALLATION INSTRUCTIONS - Rear Hitch Cover Kit

7. INSTALLATION OVERVIEW

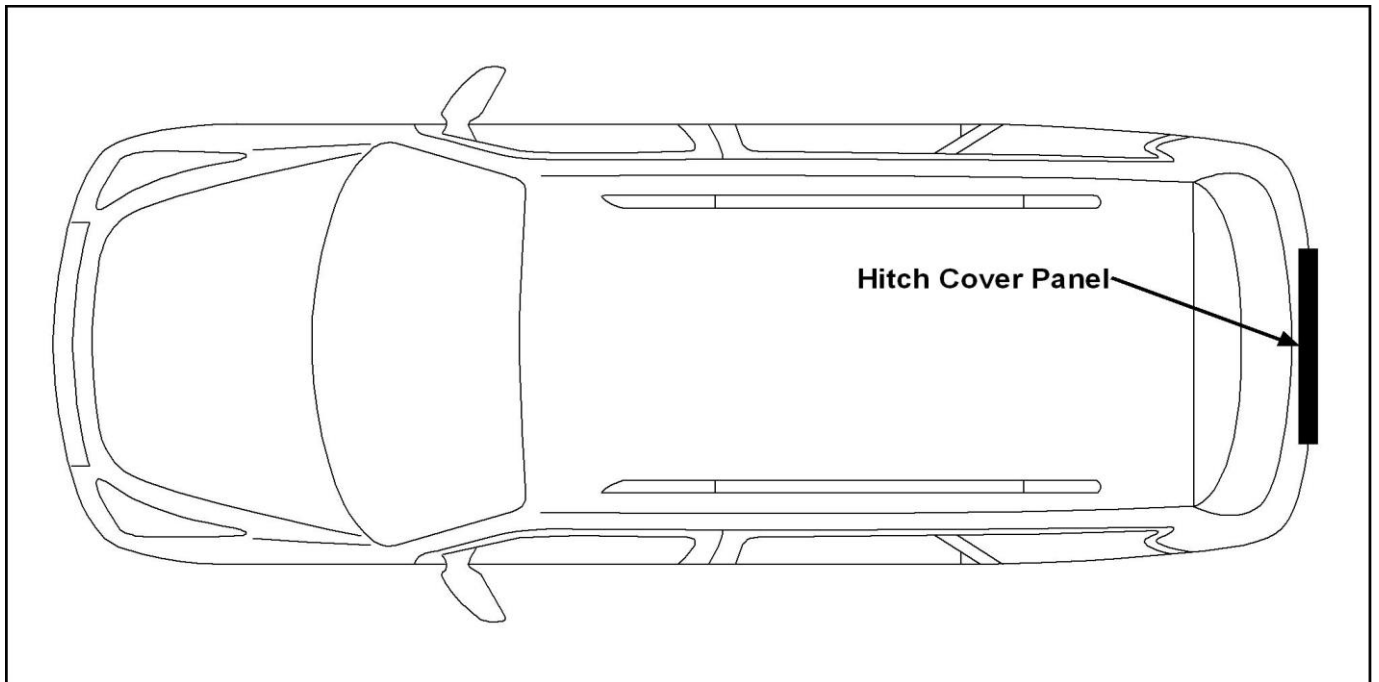

8. CRITICAL STEPS

The following steps are critical and must be performed **EXACTLY** as specified to ensure proper installation:

- Location of the cover panel must be followed exactly as described in this instruction.
- Be sure to apply masking tape as needed in order to protect any areas that may become scratched or damaged.
- Test the functionality of the kit before final clean up.

9. Order of Installation

1. Mount template.
2. Cut hole for Cover Panel.
3. Mount Cover Panel.

INSTALLATION INSTRUCTIONS - Rear Hitch Cover Kit

10. INSTALLATION PROCEDURE

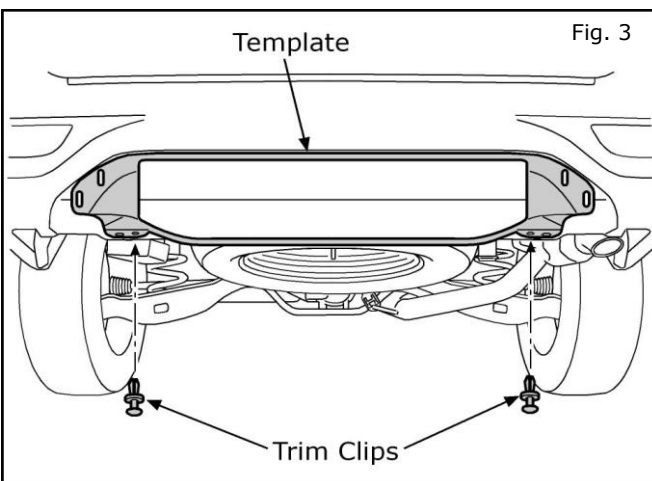
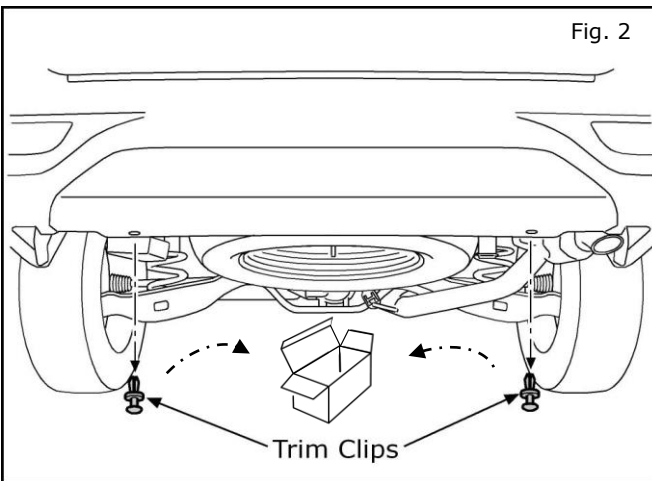
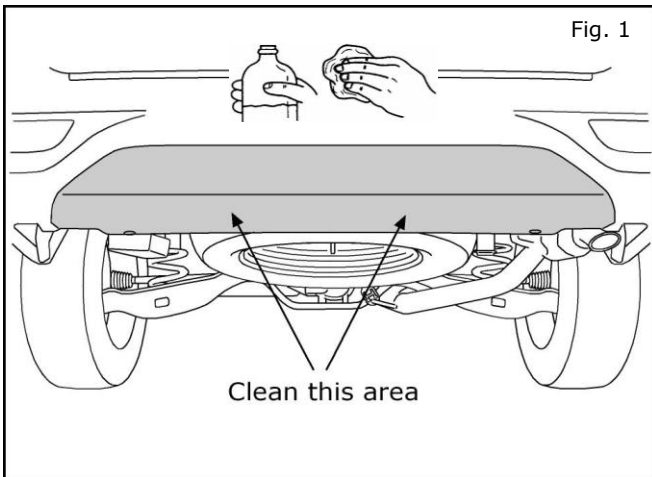

- 1) Raise vehicle on hoist to working height.
- 2) Use a clean, lint-free cloth to clean installation surface (shaded area) with isopropyl alcohol (figure 1).
- 3) Use a flathead screwdriver to remove two (2) push pins from under side of bumper. Save trim clips for next step (figure 2).
- 4) Position cutting template to rear bumper by lining up trim clip holes on bumper and cutting template. Reinstall two (2) push pins previously removed in step 2 (figure 3).

INSTALLATION INSTRUCTIONS - Rear Hitch Cover Kit

10. INSTALLATION PROCEDURE

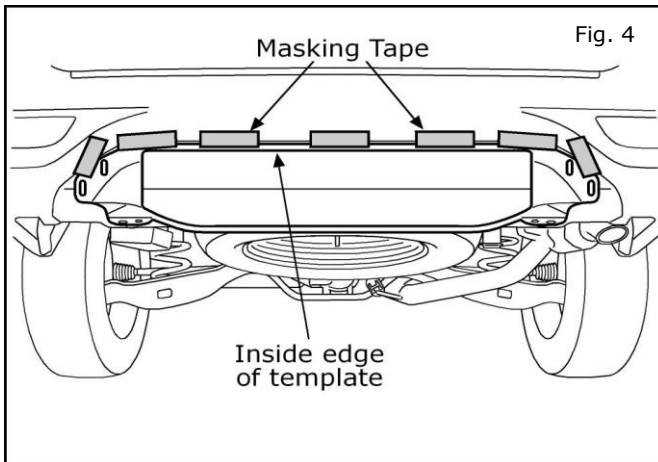

NOTE:

Apply pressure to be sure template is positioned firmly against the bumper surface.

- 5) Apply masking tape around all outside edges of template to secure it to bumper, as shown in Fig 4.



CAUTION

- Safety glasses required beyond this step

- 6) Using 6.0mm drill bit drill holes(8 places) at the positions shown(figure 5).

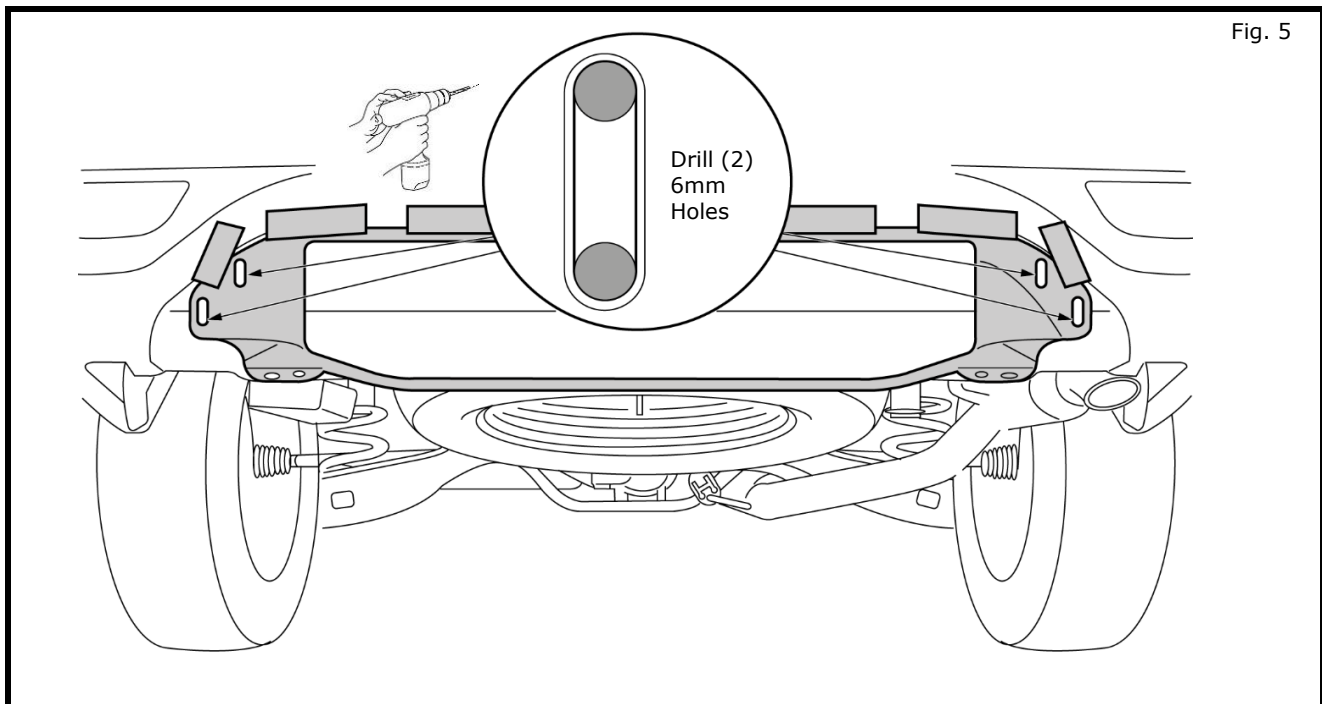

INSTALLATION INSTRUCTIONS - Tow Hitch Finisher

10. INSTALLATION PROCEDURE

- 7) Remove any tape that covers inside edge of template.
- 8) Using 6.0mm drill bit drill holes inside of template(8 places) as shown(figure 6). This will help cutting process in the following steps.

NOTE: Be sure Drill Bit is slightly below edge of template.

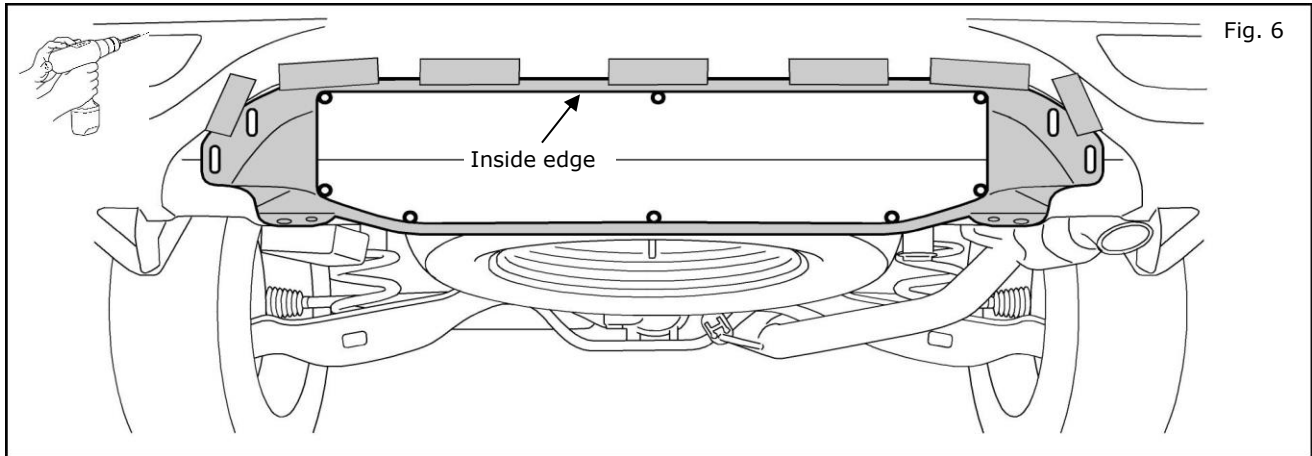

- 9) Use small reciprocating air saw to cut bumper plastic and connect holes previously drilled in step above. Follow edge of template and work carefully from one hole to next until complete(figure 7).

NOTE: Move slowly and firmly to keep the cutting tool against the cutting template.

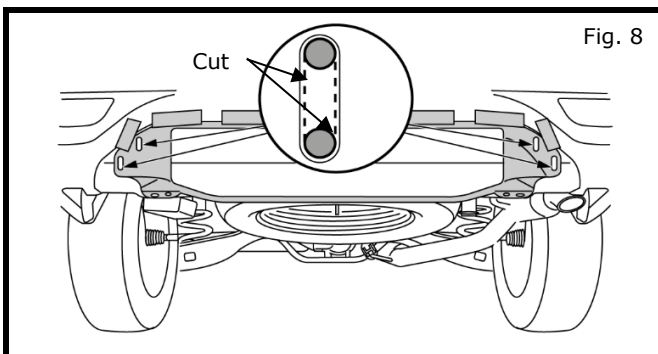
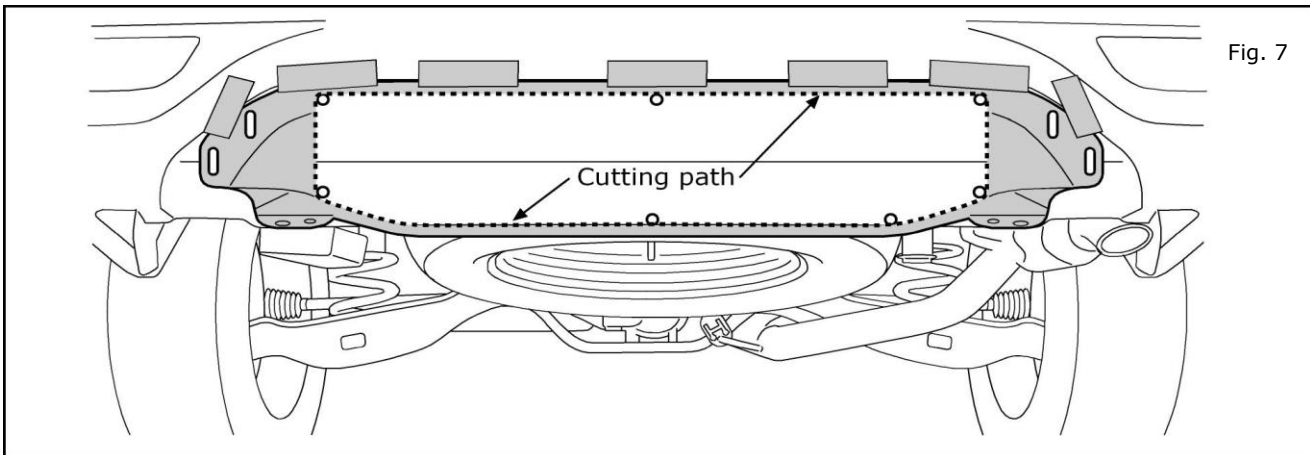

- 10) Use a small reciprocating air saw to cut bumper plastic and connect 2 holes at each slot. Follow both edges of template(figure 8).

NOTE:
Move slowly and firmly to keep the cutting tool against the cutting template.

INSTALLATION INSTRUCTIONS - Tow Hitch Finisher

11. INSTALLATION PROCEDURE

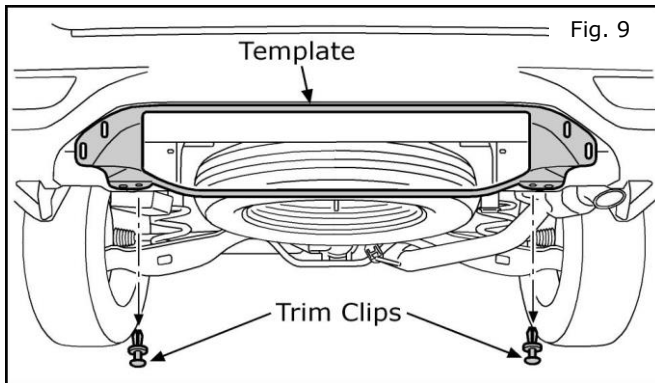

- 11) Remove cutting template:
 - a) Remove all masking tape.
 - b) Use flathead screwdriver, remove two trim clips from template.
 - c) Re-install trim clips to attach bumper to brackets (figure 9).

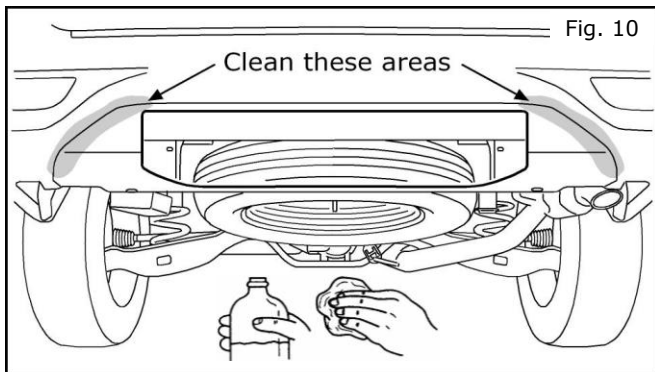

- 12) Using clean, lint-free cloth, clean installation surface (shaded area) with isopropyl alcohol (figure 10).

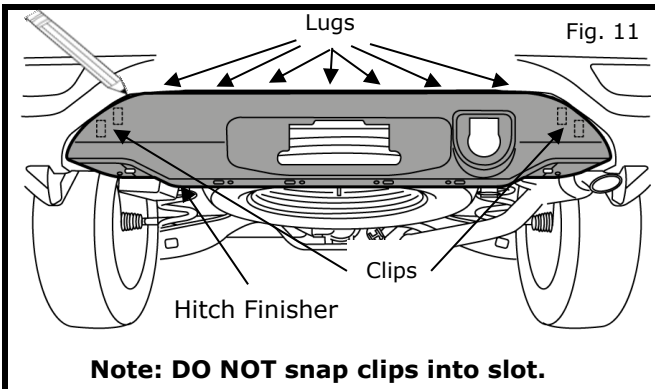

- 13) Lightly position Hitch Finisher against bumper. Four (4) tabs on back of Cover will align with attachment slots. Push and hold Finisher in upward position.

- DO NOT ENGAGE 4 CLIPS
- ENSURE LUGS ARE FULLY ENGAGED

NOTE:

Lugs need to be fully engaged with fascia edge. This may require additional deburring of cut edge.

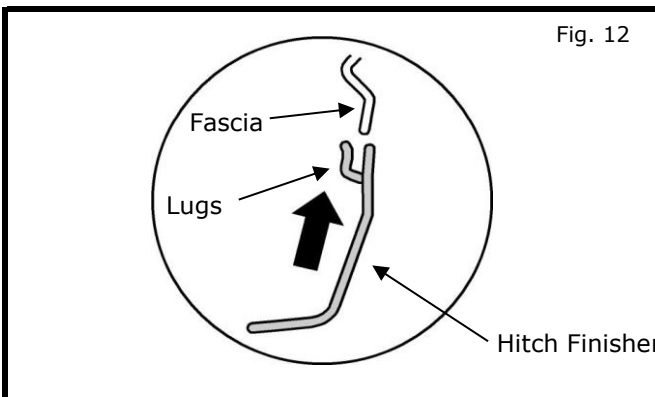

- 14) Use #2 pencil to lightly mark bumper as shown in Fig. 11.

- 15) Remove hitch finisher.

INSTALLATION INSTRUCTIONS - Tow Hitch Finisher

11. INSTALLATION PROCEDURE

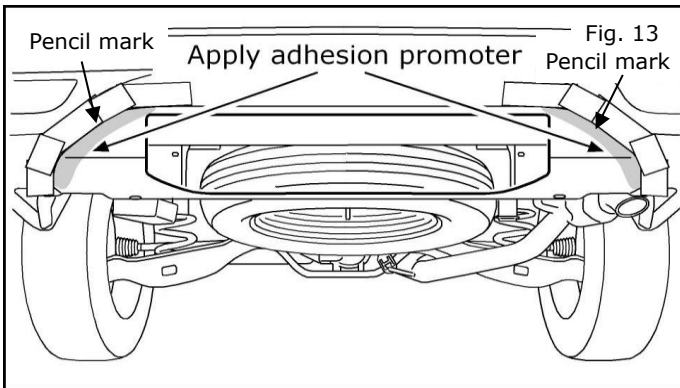

- 16) Apply masking tape against pencil mark as shown to protect visible areas from adhesion promoter (figure 13).

NOTE:

Tape should line up with pencil mark as shown.

- 17) Apply thin coating of Adhesion Promoter to shaded area (figure 13). Remove masking tape immediately. Wait two minutes and not more than one hour to complete installation.

NOTE:

Wear hand protection when working with adhesion promoter.

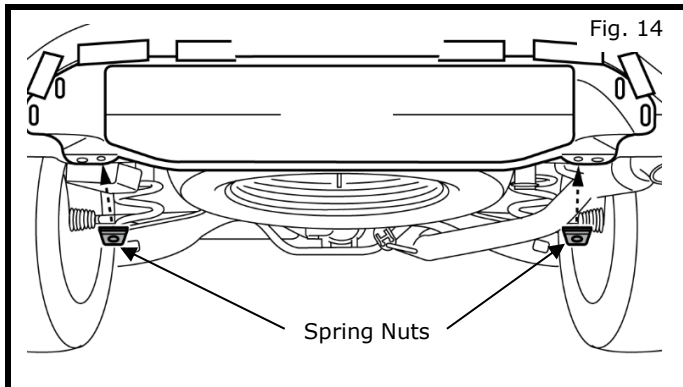

- 18) Install two (2) spring nuts onto bumper fascia (figure 14).

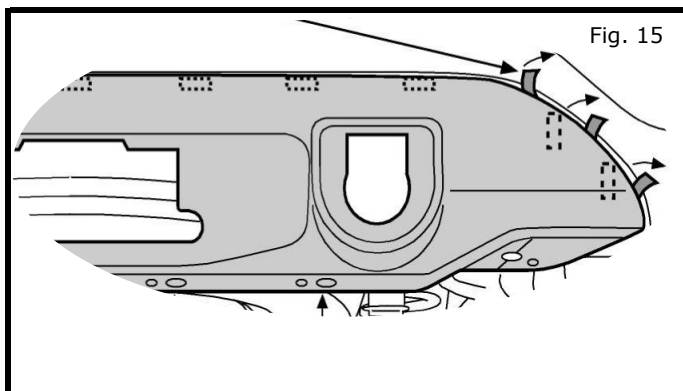

- 19) Carefully fold back pull tabs on tape so they are exposed (figure 15). DO NOT pull tabs off of tape at this time.

INSTALLATION INSTRUCTIONS - Tow Hitch Finisher

11. INSTALLATION PROCEDURE

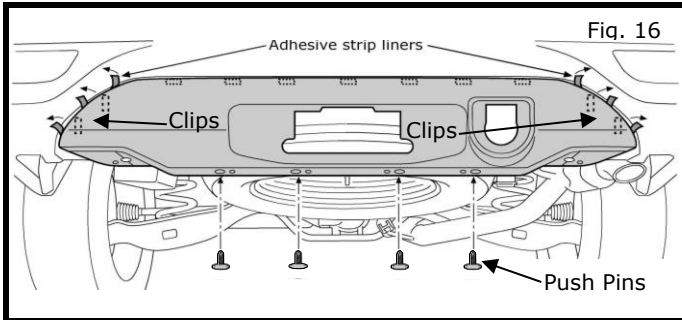

- 20) Reposition hitch cover against bumper fascia. Fully engage all seven (7) lugs (reference Fig. 11) onto fascia edge, press firmly at 4 clip locations to ensure all four (4) clips engage into fascia slots (figure 16).
- 21) Install four (4) Push Pins along bottom of finisher (figure 16).
- 22) Gently pull all 6 tape tabs from under hitch finisher and press firmly to ensure proper tape adhesion (figure 16).

NOTE:

Use a roller or burnish by hand to apply a minimum of 15lbs of pressure along length of tape (starting at top of part and working downward).

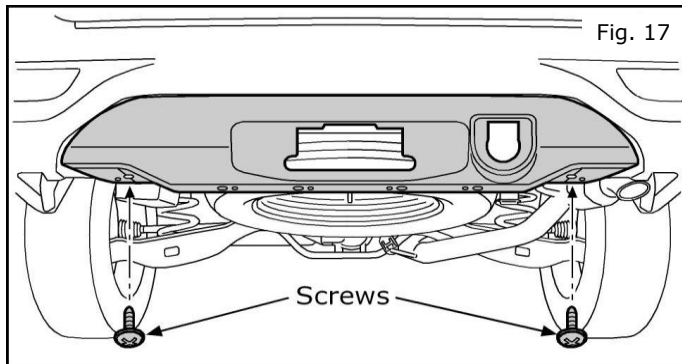

- 23) Install and tighten two (2) screws (figure 17).