



GENUINE PARTS

INSTALLATION INSTRUCTIONS

DESCRIPTION: Bumper Upper Protector

APPLICATION: QX30

PART NUMBER: KE6205D000

KIT CONTENTS:

Item	Qty.	Part Description	Service Part Number
A	1	Bumper Upper Protector	---
B	2	Installation Pattern	---
C	1	3M VHB	---
D	1	Installation Manual	---

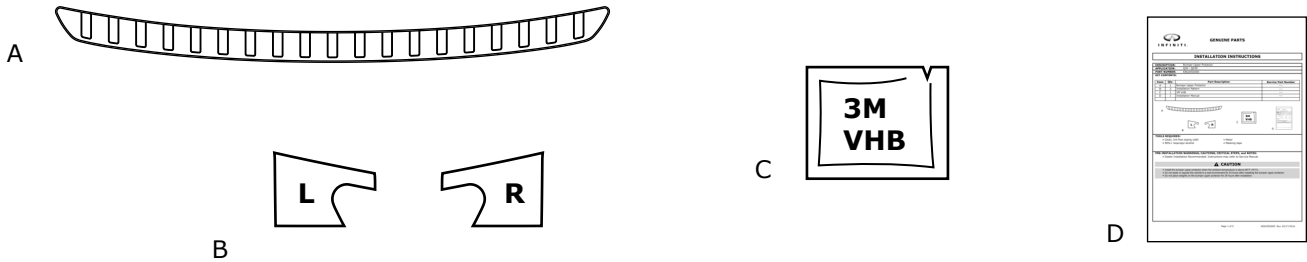

TOOLS REQUIRED:

- Clean, lint-free wiping cloth
- 90%+ Isopropyl alcohol
- Meter
- Masking tape

PRE-INSTALLATION WARNINGS, CAUTIONS, CRITICAL STEPS, and NOTES:

- Dealer Installation Recommended. Instructions may refer to Service Manual.

⚠ CAUTION

- Install the bumper upper protector when the ambient temperature is above 60°F (15°C).
- Do not wash or expose the vehicle to a wet environment for 24 hours after installing the bumper upper protector.
- Do not place weights on the bumper upper protector for 24 hours after installation.

INSTALLATION PROCEDURE:

Fig.1

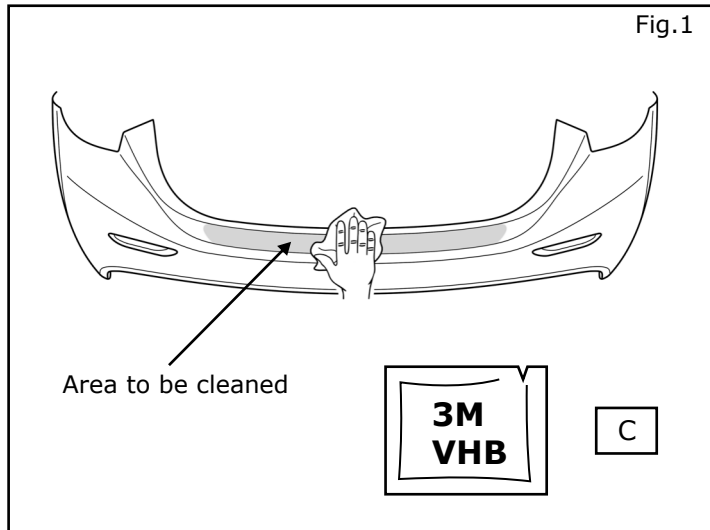

- 1) Clean upper portion of rear bumper thoroughly with soap and water to remove any dirt or debris and allow to dry.
- 2) Bumper upper protector installation preparation.
 - a) Open rear hatch.
 - b) Use 3M VHB (Item C) to clean the area of rear bumper where part will be installed in order to guarantee proper adhesion.
 - c) Allow time to dry thoroughly.

⚠ CAUTION

Failure to clean the mounting surface properly may cause the adhesive tape to have poor adhesion to the vehicle.

Fig.2

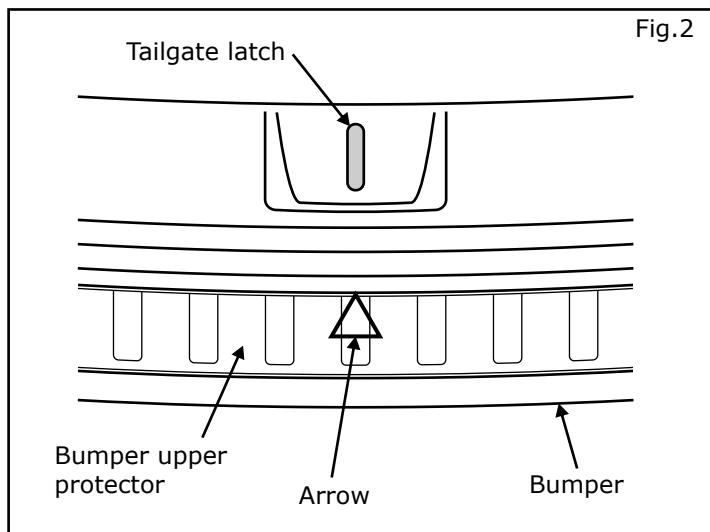

- 3) Dry fit the upper bumper protector to the vehicle. Align the upper bumper protector centering arrow with the tailgate latch.

Fig.3

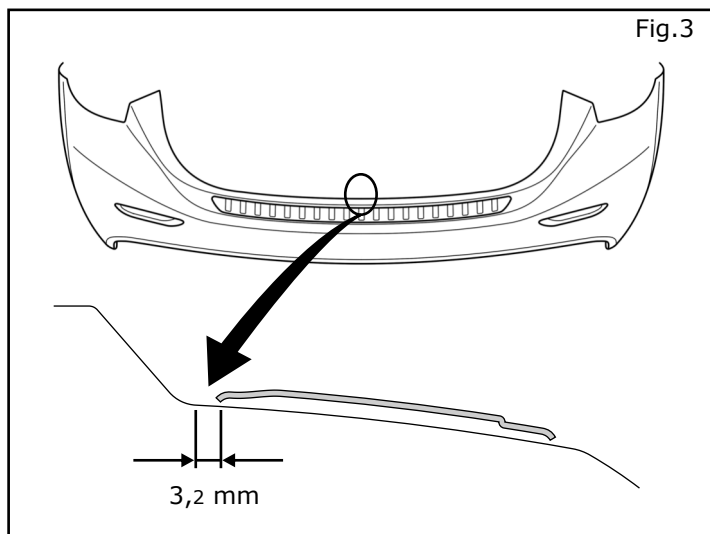

- 4) Measure the distance from the corner radius of the rear bumper to the edge of the bumper upper protector (3,2 mm).
- 5) Confirm upper bumper protector location on vehicle.

INSTALLATION PROCEDURE:

Fig.4

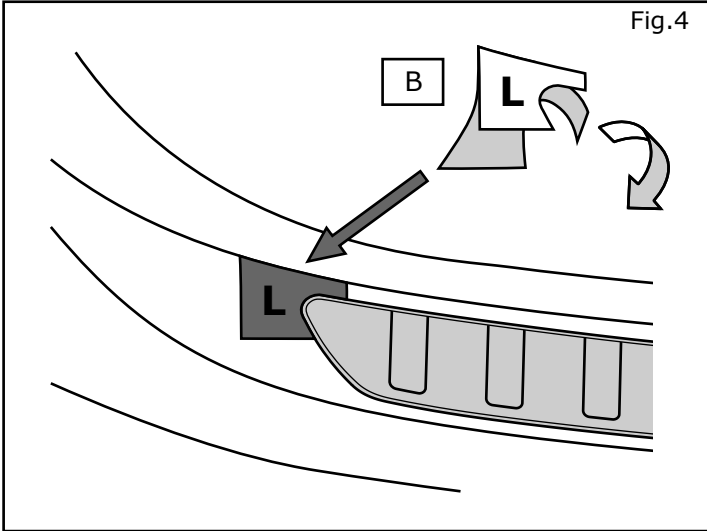

- 6) Left (L) installation pattern preparation (Item B).
- a) Remove completely the rear liner of the left installation pattern.
 - b) Apply left installation pattern on the rear bumper at left edge of part.

Fig.5

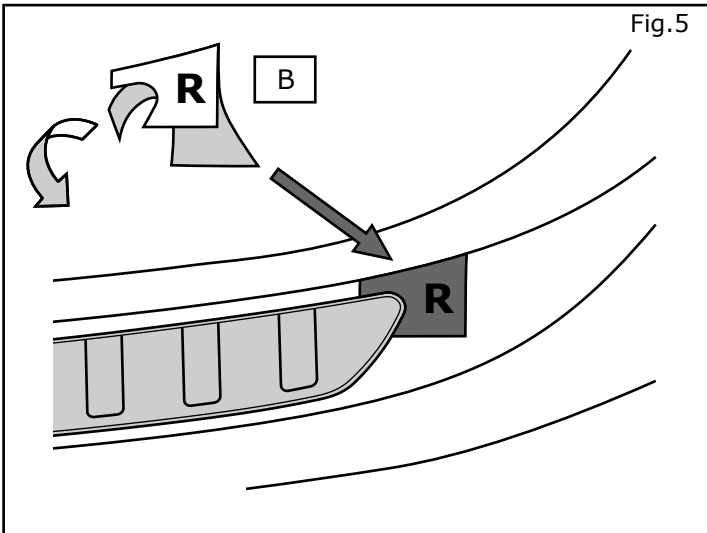

- 7) Right (R) installation pattern preparation (Item B).
- a) Remove completely the rear liner of the right installation pattern.
 - b) Apply right installation pattern on the rear bumper at right edge of part.

Fig.6

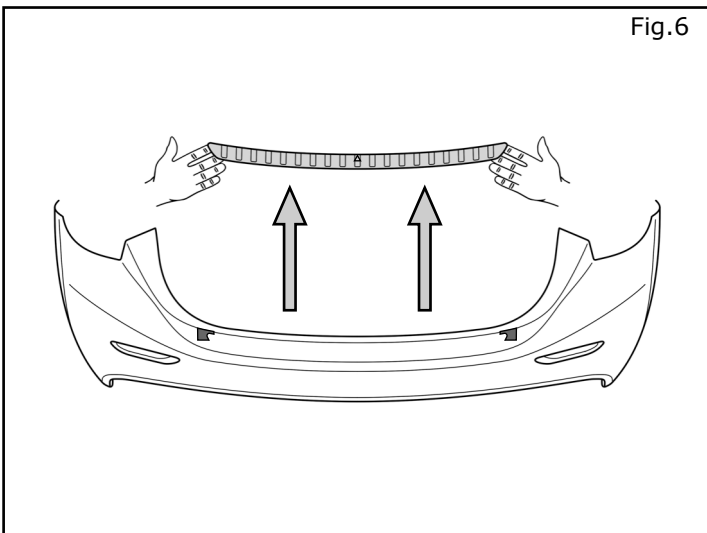

- 8) Remove part from vehicle.

INSTALLATION PROCEDURE:

Fig.7

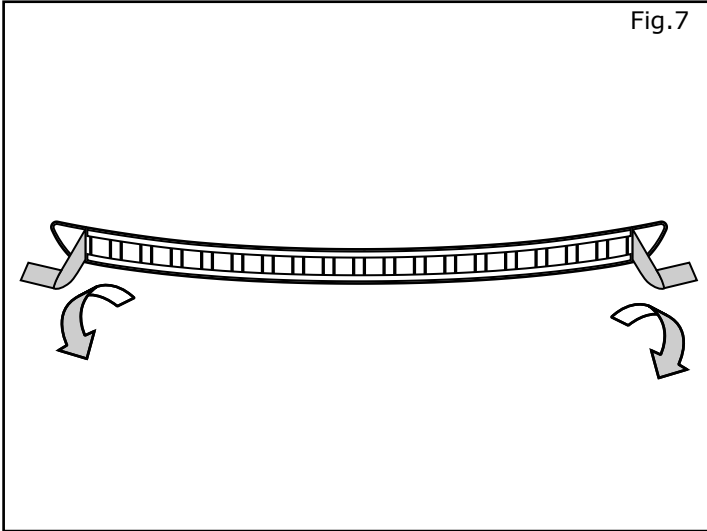

- 9) Fold the clear tabs over left and right edge of the part and remove completely left and right rear liners.

Fig.8

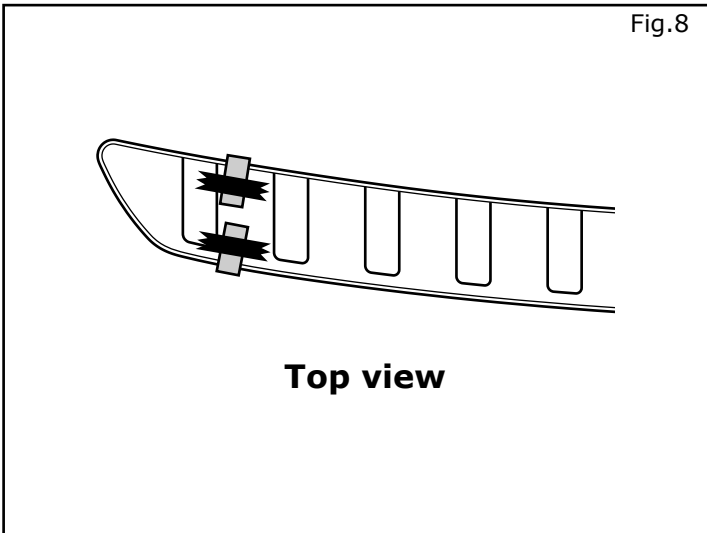

- 10) Fold the clear tabs of the two horizontal rear liners over the edge of the part and secure to the top surface with masking tape.

Fig.9

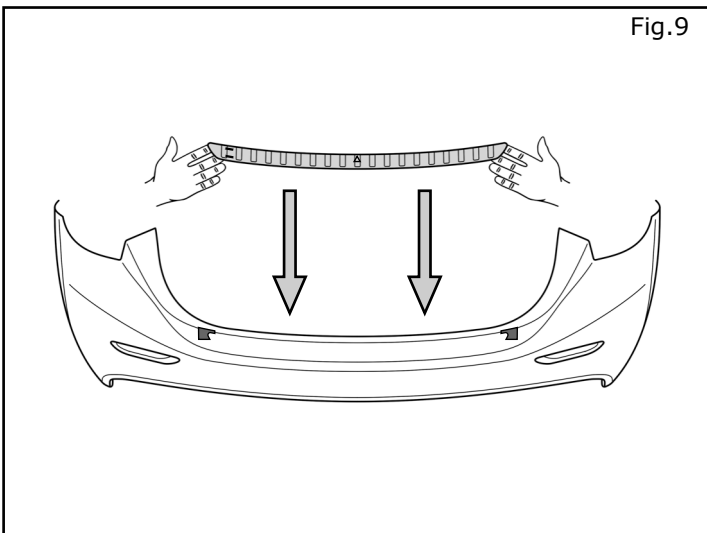

- 11) Place part back on vehicle and align it to left and right installation patterns (Item B).

INSTALLATION PROCEDURE:

Fig.10

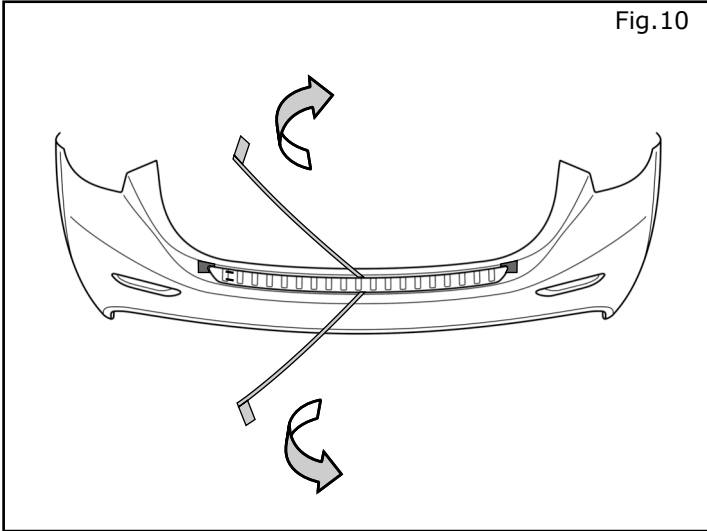

Fig.11

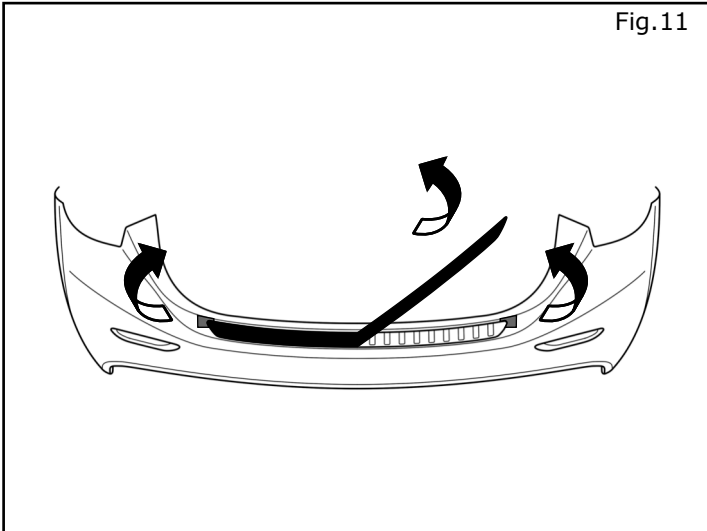
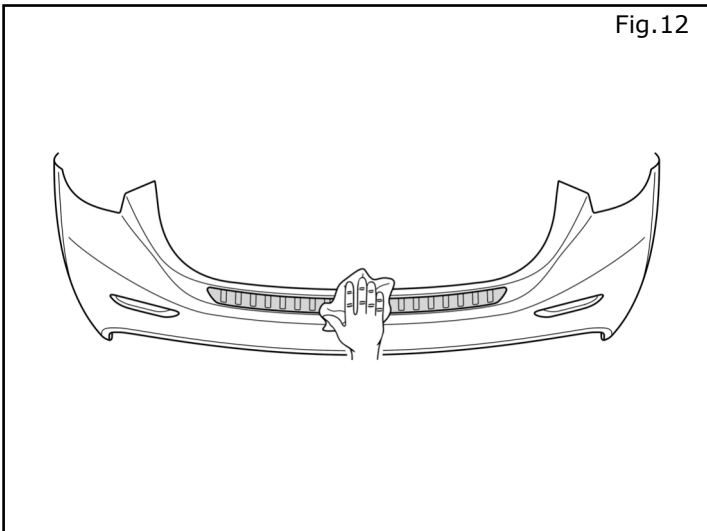

Fig.12



FINAL INSPECTION:

- Verify exterior is not damaged.

- 12) While holding part in position with one hand, carefully pull the clear tabs to remove the rear liners completely.
- 13) Using a clean lint-free cloth, start at the center and apply 15 lbs of pressure along the tape path.
- 14) Remove masking tape from all tabs on top of part.
- 15) To ensure adequate attachment, re-apply 15 lbs of pressure across the entire part.
- 16) Remove transparent protective film from all upper bumper protector.
- 17) Remove left and right installation patterns.
- 18) Use a clean lint-free cloth and isopropyl alcohol to clean the bumper upper protector and the installation area of rear bumper.
- 19) Close rear hatch.
- 20) Do not expose vehicle to moisture for 24 hours.