



GENUINE PARTS



## INSTALLATION INSTRUCTIONS

**DESCRIPTION:** Interior Accent Lighting Kit

**APPLICATION:** Pathfinder / QX60

**PART NUMBER(S)** T99F3 6SA00

**REQUIRED FOR INSTALLATION:** 999Q9 AY000 (Accessory Service Connector) - **Not Included in Accent Lighting Kit**

**KIT CONTENTS:**

Item	Qty.	Part Description	
A	1	Control Module	Not Serviceable- Parts of kit- T99F3 6SA00  999V2 AW000
B	1	Front Footwell Lights and Harness Assembly	
C	1	2-Button On/Off-Brightness Selection Switch and harness	
D	1	Vehicle Interface Harness (Power Harness)	
E	1	Hardware Kit	
F	1	Quick Reference Card	
G	1	Installation Instruction Replacement Template	

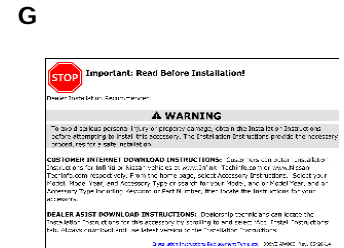
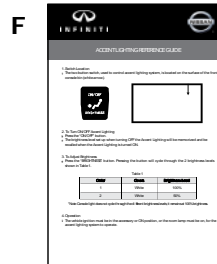
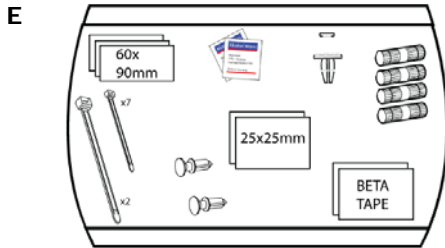
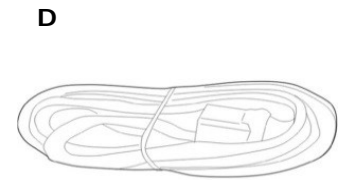
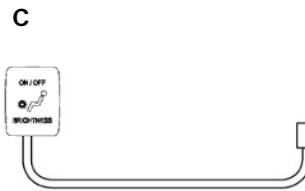
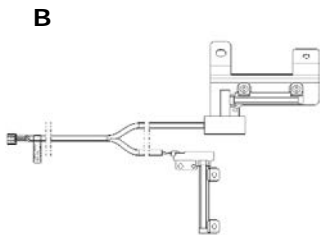
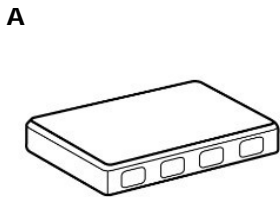

Item	Qty.	Part Description	Service Part Number
AA	1	Accessory Service Connector (ASC) <b>(NOT INCLUDED IN KIT)</b>	999Q9-AY000

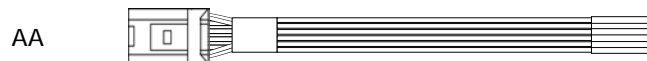

**Note:** 1 or 2 ASC may already be installed in the vehicle.

**TOOLS REQUIRED:**

- Trim Stick (Nylon)
- (Awl) Center Hole Punch
- 1/8" , 3/8" , 3/16" & 5/16" drill bits
- Side Cut Pliers
- 90 Degree Small Drill
- 1/8" & 3/8" #4 Step Drill
- Electrical Tape
- Deburring Tool

**Vehicle Preparation:**

**⚠ CAUTION**

• **Always confirm the ignition is in the "OFF" position before changing the switch condition.**

- 1) Apply parking brake
- 2) Confirm vehicle is not in the default shipping state or "Inventory position" as shown below. Failure to confirm vehicle has been removed from this state will result in loss of normal vehicle operation.
- 3) Locate Extended Storage Switch in cabin fuse block. Confirm it is in the "Customer" position. See below for reference.

a) To remove transit mode (Fuse Block):

1. Remove fuse cover lid.
2. Push down shorting pin.
3. Ign On 2 times without starting the vehicle.

b) To remove transit mode (BCM):

1. Confirm ignition switch is in "OFF" position.
2. Simultaneously push the signal and wiper switch fully down for two (2) seconds.

**NOTE:** While in BCM Transit Mode, turn signal indicators will remain illuminated for one minute.

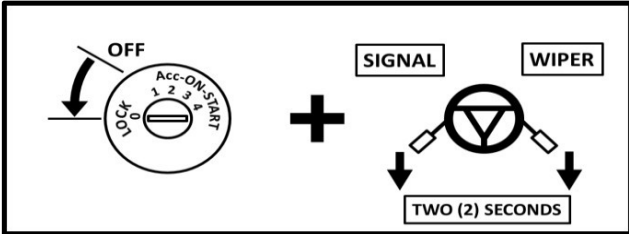
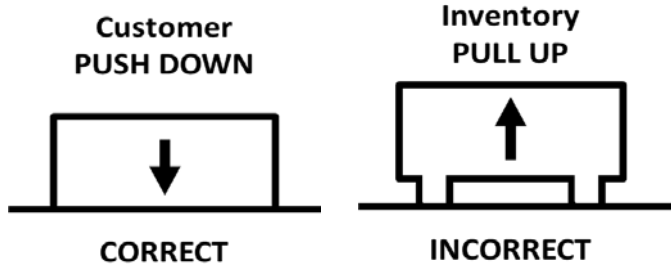

c) To return to transit mode for storage:

1. Ign Off.
2. Remove fuse cover lid.
3. Pull up shorting pin.
4. Assemble fuse cover lid.
5. Ign On 2 times without turn the vehicle on.
6. Confirm transit mode condition on meter

**NOTE:** Typical vehicle condition shown above. Switch is easily identifiable by the permanent, push-pull fuse holder. Actual position on the fuse block may vary, vehicle to vehicle.

Condition	Switch Position	Note
Vehicle is delivered to the dealer	Inventory Condition	
Technician performs PDI	Customer Delivery	Return to Inventory position after PDI.
Customer test drives the vehicle	Customer Delivery	Return to Inventory position after test drive.
Vehicle is being stored at the dealer	Inventory Condition	
Vehicle is delivered to customer	Customer Delivery	

**NOTE:** The Extended Storage Switch is only an aid to improve battery life during vehicle storage at the dealer. If the Extended Storage Switch fuse ever needs service after vehicle delivery, discard the Extended Storage Switch and install the correct fuse in its place.

- 4) Turn ignition switch to "ON" position
- 5) Record the customer radio presets and other presets as required.

Preset	1	2	3	4	5	6		

- 6) Put shift lever in "P" position for A/T and CVT or "1st" for M/T
- 7) Turn ignition switch to "OFF" position
- 8) Use seat and floor protection.

## PRE-INSTALLATION CAUTION/NOTES

- Dealer installation recommended. Instructions may refer to Service Manual
- Installation may require special tools
- This part is to be installed within a surface temperature range of 65-100°F

## CAUTION

- This accessory must only be installed as specified in these instructions.
- Ensure at all times that parts are securely fitted and will not compromise the safe function of vehicle systems

## INSTALLATION PROCEDURE:

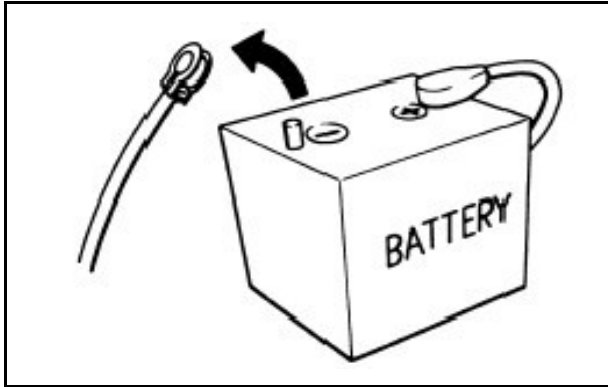

- 1) Turn ignition switch to "OFF" position
- 2) Disconnect the negative battery terminal.
  - a) Lower both the driver and passenger windows to prevent damage.
  - b) Disconnect the negative battery terminal.

## Order of Installation

- a. Interior preparation - remove panels
- b. Install Front Footwell light - Passenger's side
- c. Install Front Footwell light - Driver's side
- d. Install Vehicle Interface Harness
- e. Install Switch
- f. Install ECU
- g. Reinstall Panels
- h. System check

## INSTALLATION OVERVIEW (Normal):

### System Block Diagram

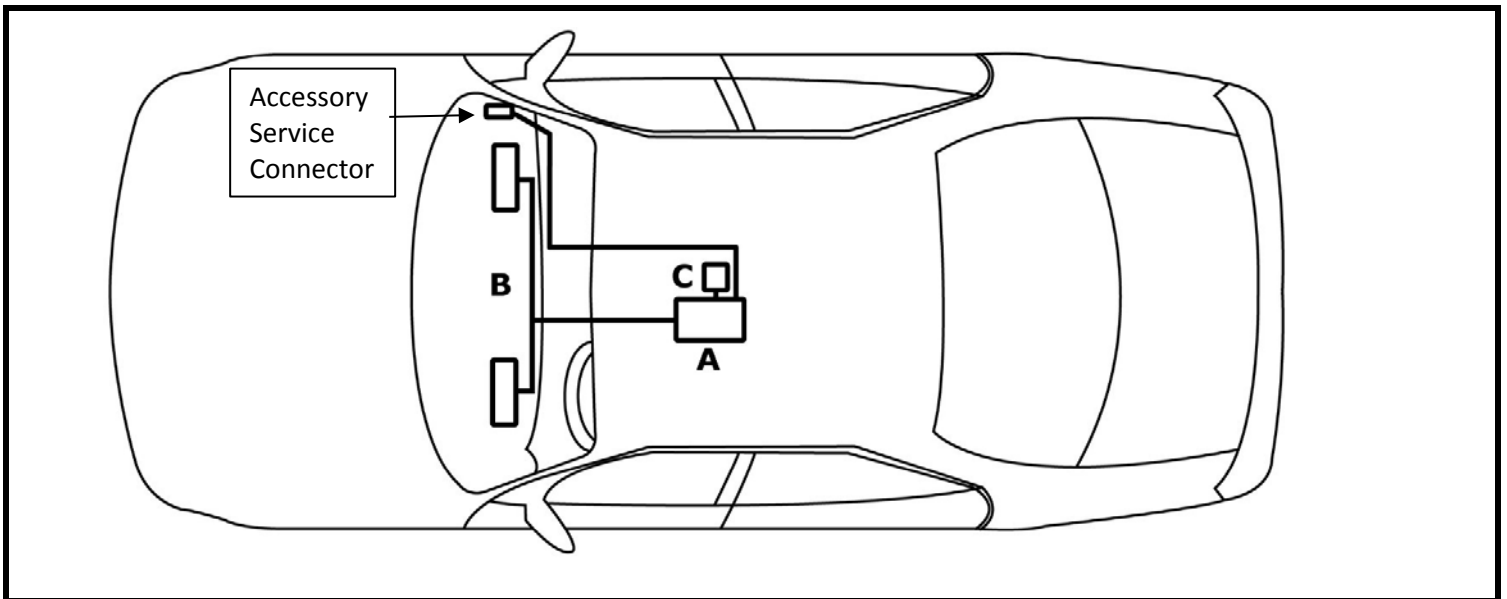
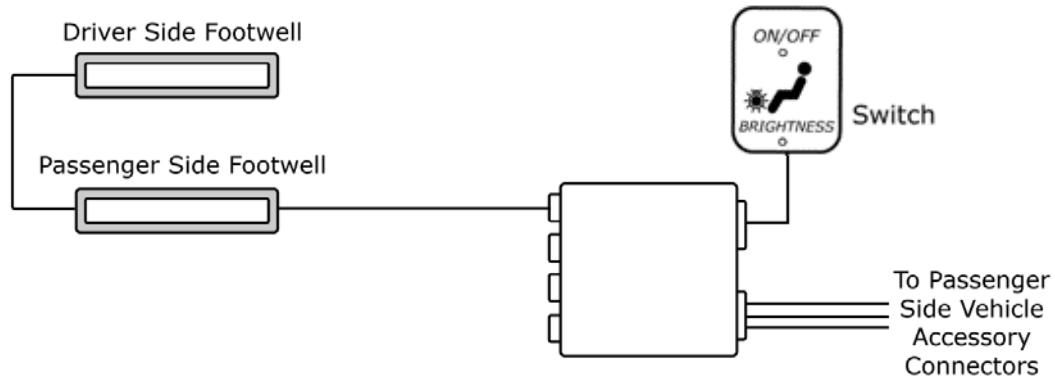

- A) Controller Module (ECU)
- B) Front Foot Well Lights
- C) Switch

### CRITICAL STEPS:

The following steps are critical and must be performed **EXACTLY** as specified to ensure proper installation:

- **Location of the lights must be followed exactly as described in this instruction.**
- **Posi-Tap™ instructions must be specifically followed as described.**

# INSTALLATION INSTRUCTIONS - Footwell Lighting Kit

## INSTALLATION PROCEDURE:

- 1) Place masking tape on indicated areas to avoid any scratches or blemishes to the interior during installation, as shown in **Fig. 1a** for QX60 or **Fig. 1b** for Pathfinder.

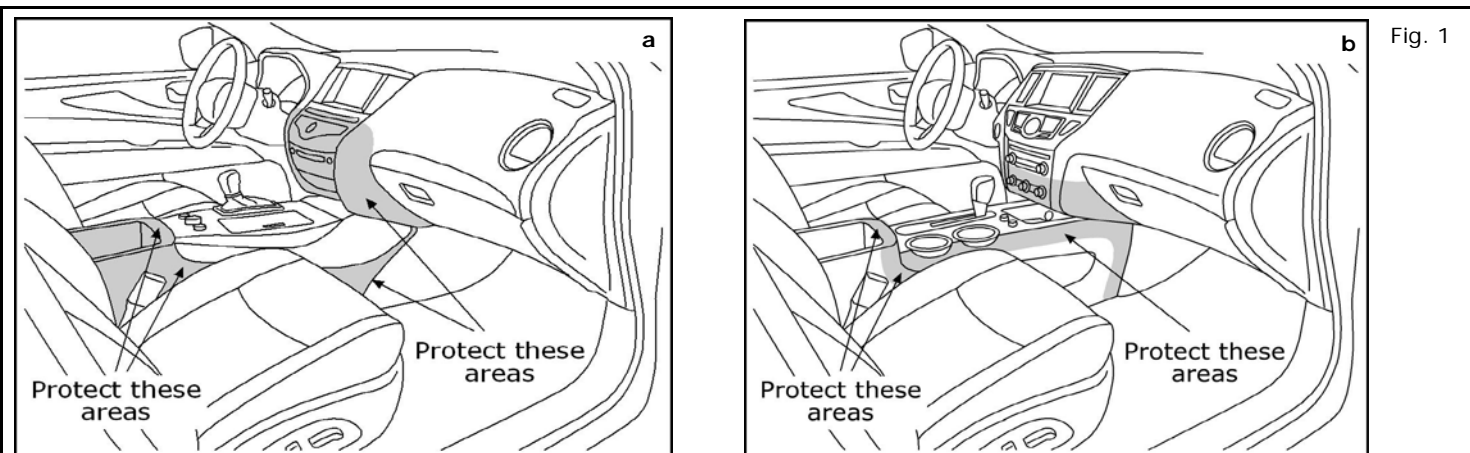

- 2) Carefully pry out center footwell panel from the passenger side of the center stack for both **QX60 (Fig. 1a)** and **Pathfinder (Fig. 1b)**. Remove rubber storage tray from center stack, in case of QX60.

**NOTE:** Be sure the front retainer clip stays with panel.

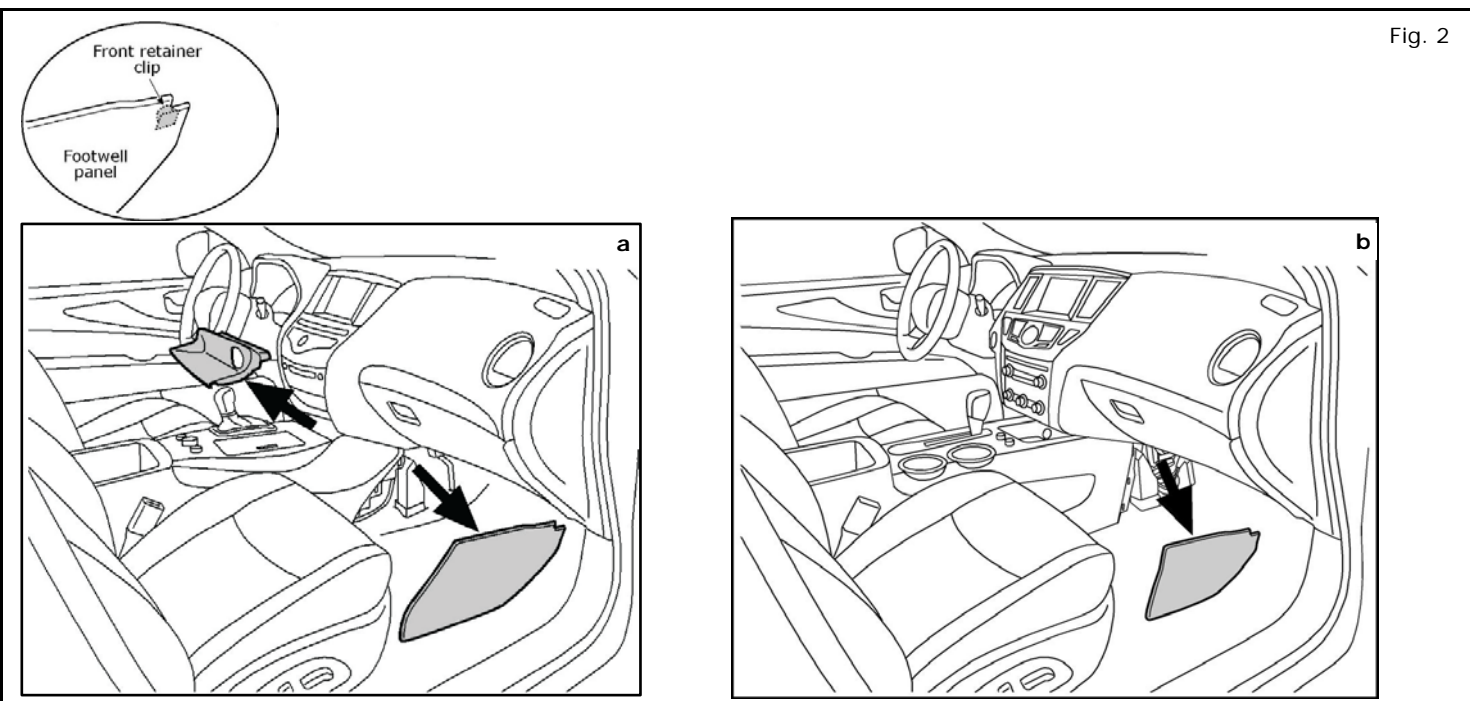

# INSTALLATION INSTRUCTIONS - Footwell Lighting Kit

## INSTALLATION PROCEDURE:

**NOTE:** For Pathfinder, Skip to Step 5

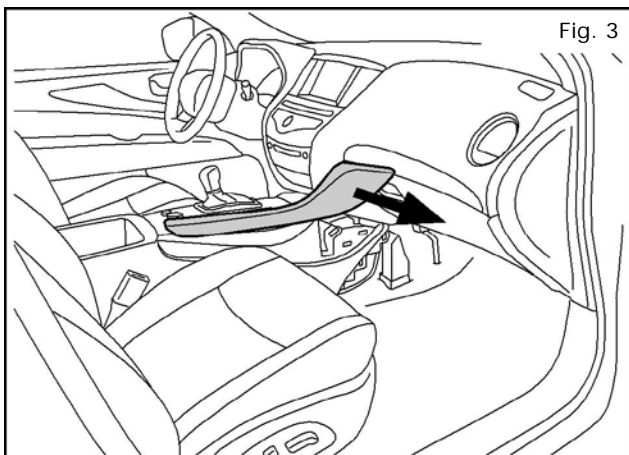

- 3) Carefully pry out center console trim panel in case of QX60 (Fig. 3).

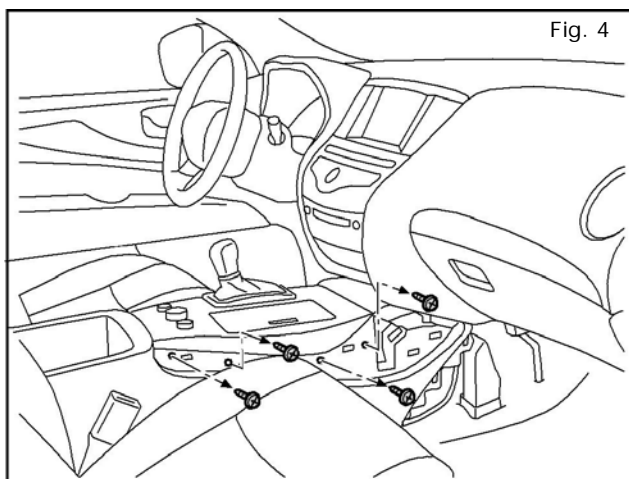

- 4) Remove four phillips screws from the side of the shifter trim panel in case of QX60 (Fig. 4).

**NOTE:**

Repeat steps 3 through 4 on the driver side.

**NOTE:**

Be sure shift lever has been moved to full back (L) position before proceeding to Step 5.

- 5) Use a pry tool to remove the bottom finisher from the shift knob and remove the retaining clip. Carefully remove shifter knob. (Fig 5a for QX60, Fig. 5b for Pathfinder)

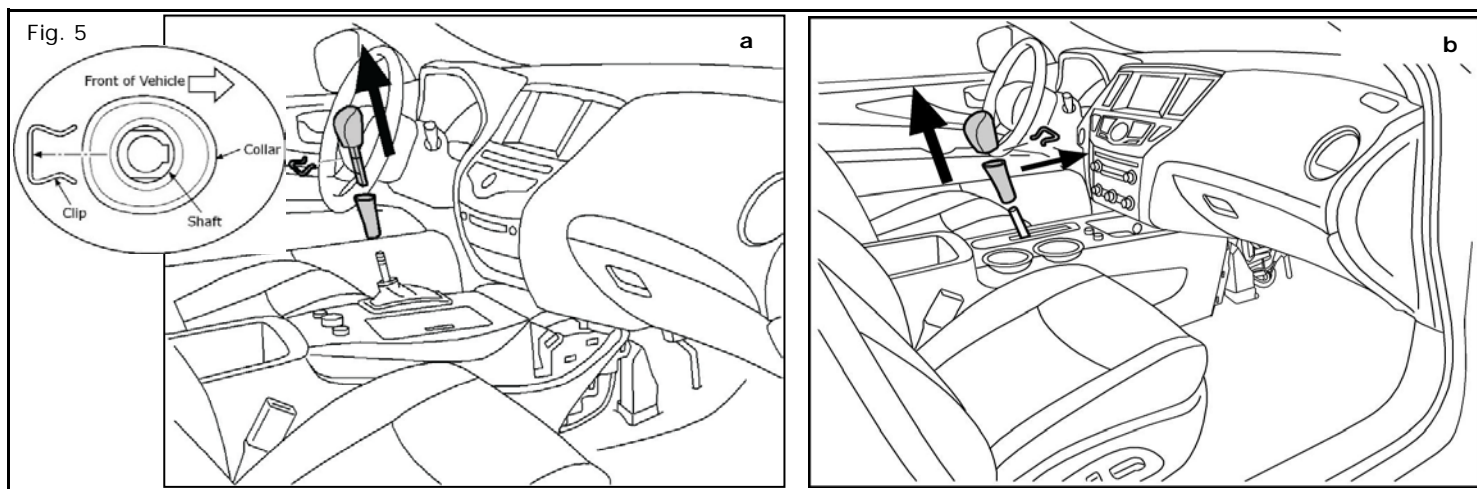

# INSTALLATION INSTRUCTIONS - Footwell Lighting Kit

## INSTALLATION PROCEDURE:

- 6) Carefully pry out shifter trim panel from the center stack. Disconnect all electrical connections and set trim panel aside. (Fig 6a for QX60, Fig. 6b for Pathfinder)

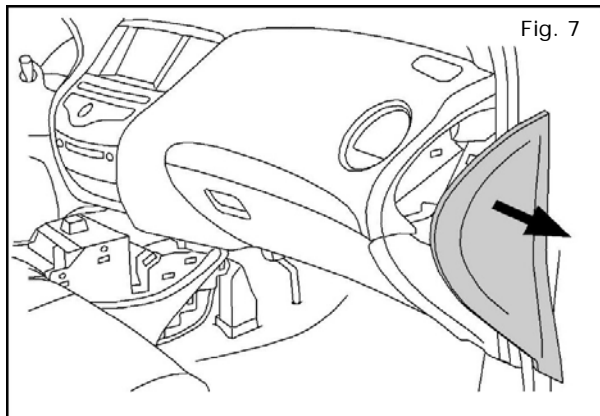
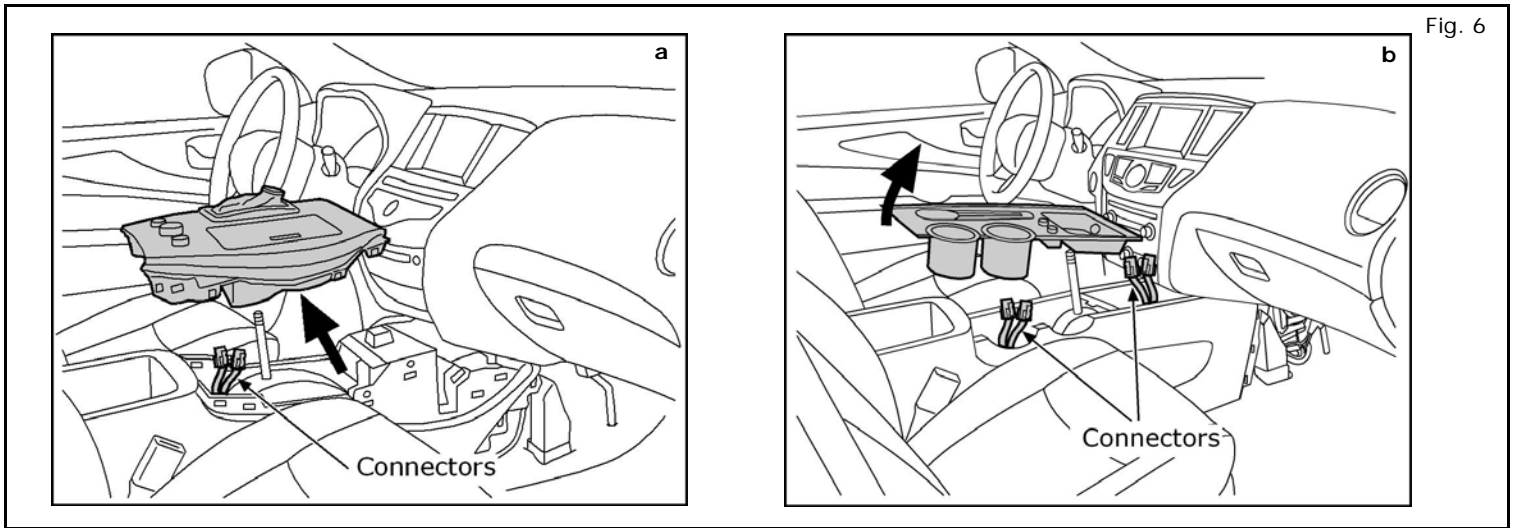

- 7) Carefully pry off the dash side mask by the passenger door.

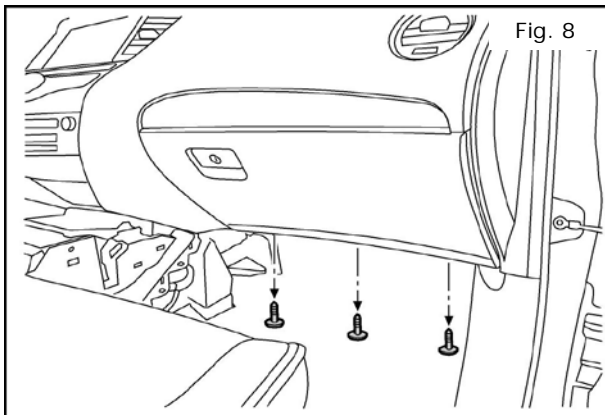

- 8) Remove three (3) Phillips head screws from the underside of the glovebox.



# INSTALLATION INSTRUCTIONS - Footwell Lighting Kit

## INSTALLATION PROCEDURE:

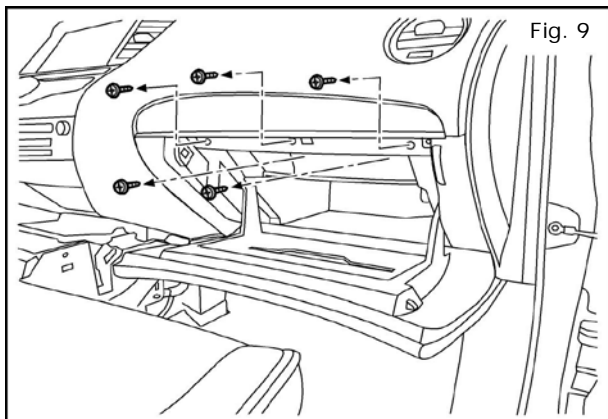

- 9) Open the glovebox door. Remove five (5) phillips head screws from inside the glovebox compartment.

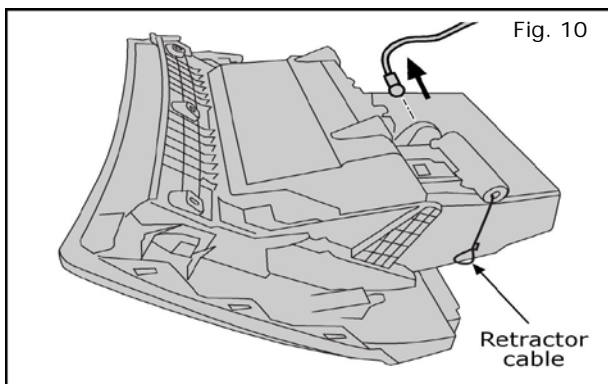

- 10) Carefully pull out the glovebox assembly. Remove the glovebox lamp and disconnect the retractor cable. Fully remove the glovebox assembly and set aside.

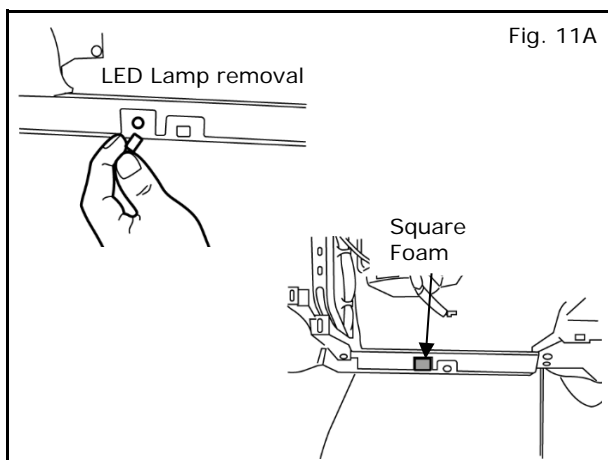

- 11) Attach passenger side lamp at bar below Lower Instrument Panel (visible after removal of Glove box & Lower Instrument Panel).
- a) Remove LED Lamp from Panel (if equipped) and cover socket with square foam (Fig. 11A).
  - b) Tape mounting area to protect panel.
  - c) Tape template at location shown in Fig. 11B.



# INSTALLATION INSTRUCTIONS - Footwell Lighting Kit

## INSTALLATION PROCEDURE:

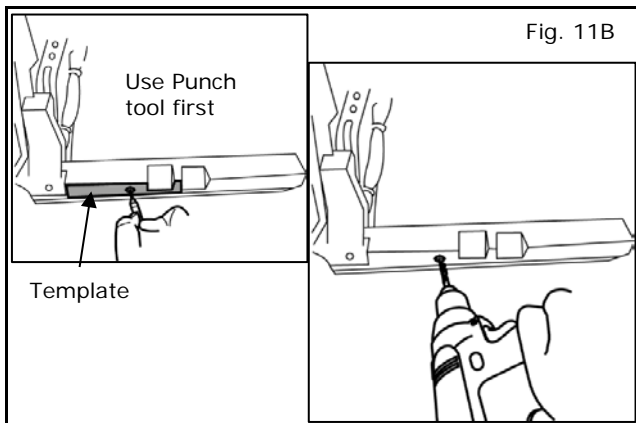

### NOTE:

Before Drilling left hole on bar, Place light assembly with Z bracket on (as shown in Fig. 13A) so that the right hole on Z bracket is placed on top of pre-existing hole on bar and verify that the location determined for the left hole based on template matches with left hole on bracket.

- d) Using punch tool, prepare hole locations to be drilled by punching through them.
- e) Remove template.
- f) Using template, drill 1/8" pilot hole from trim rear to front .
- g) Use stop on drill to go no more than 1/2" deep. Drill 5/16" hole from trim rear to front.

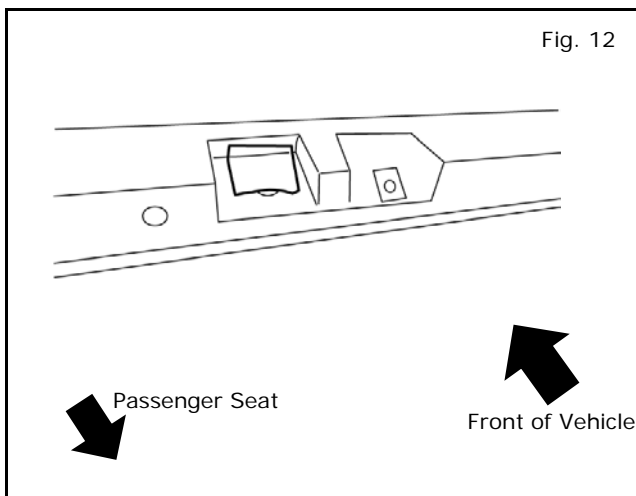

- 12) Ensure bar looks as shown in Fig. 12 after drilling.

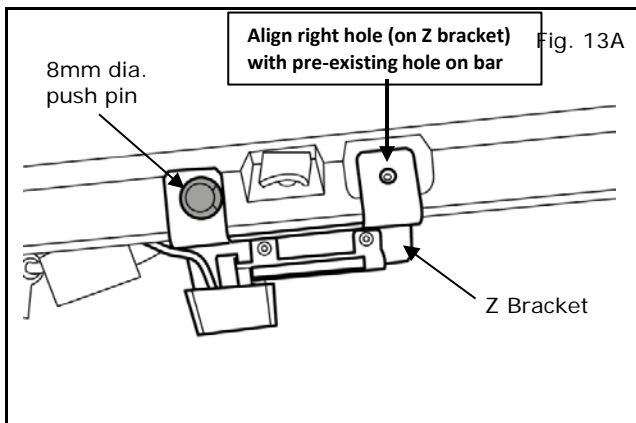

- 13) Carefully attach Z Bracket (with lamp) covering bar using one 8mm dia. push pin clip (provided in kit) on left hole pushed from passenger seat to front of the vehicle as shown in Fig. 13A.

### NOTE:

Align right hole on Z bracket with pre-existing hole on bar, prior to installation of push pin to allow for re-attachment of glove box

Verify the visibility and alignment of hole again after push pin installation

# INSTALLATION INSTRUCTIONS - Accent Lighting Kit

## INSTALLATION PROCEDURE:

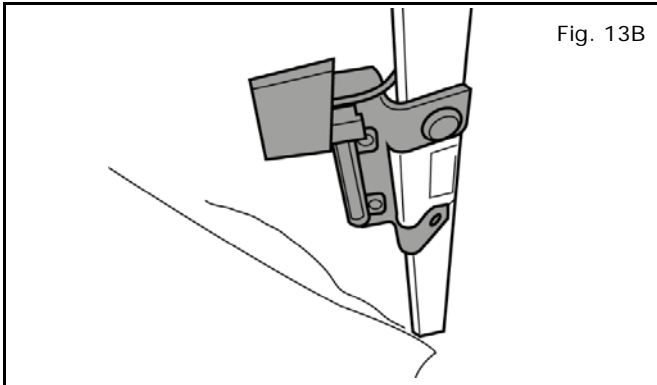

Fig. 13B

### NOTE:

Ensure Z Bracket is oriented as shown in Figure 13B.

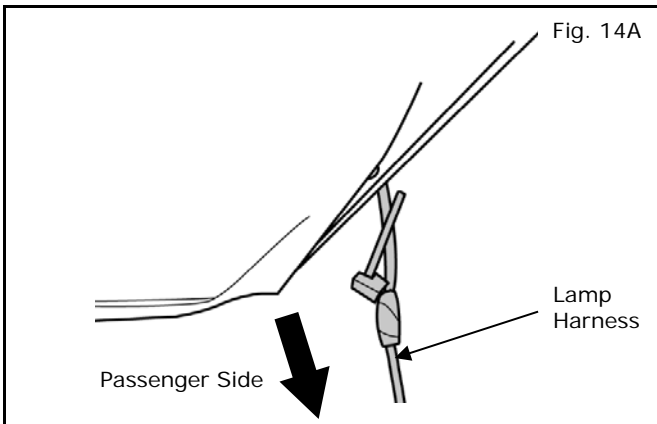

Fig. 14A

- 14) Routing Lamp Harness to Driver side
  - a) Tape Driver side Lamp harness to 30" wire tie, as shown to route it across the center console to Driver side.

### NOTE:

**DO NOT Disturb Drain Tube (if any).**  
Ensure Harness routes behind and under Drain Tube (if any).

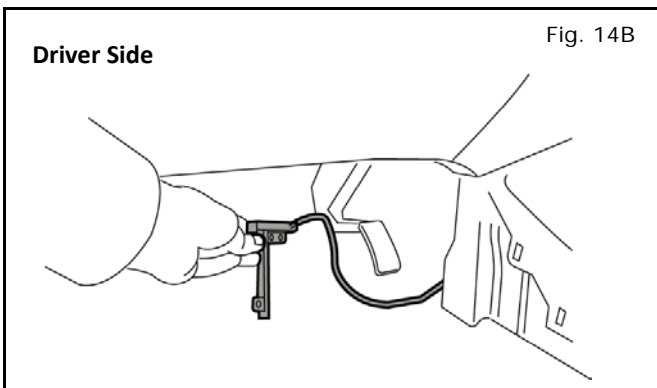

Fig. 14B

- b) Pull the harness out on the Driver side.
  - c) Remove the 30" wire tie attached to lamp harness, once routed.

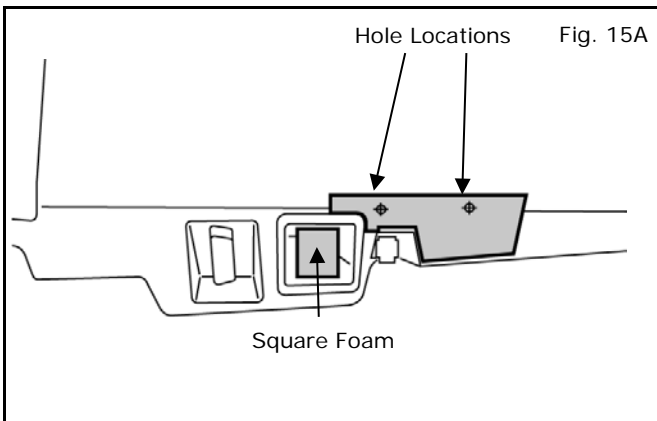
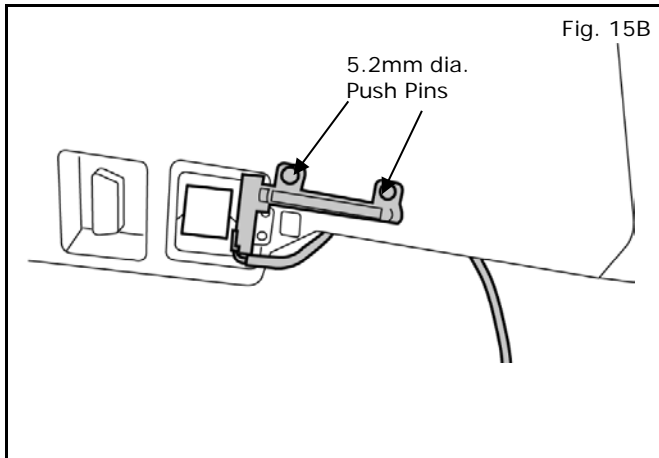

Fig. 15A

- 15) Mount lamp on Driver side lower instrument panel.
  - a) Remove LED Light from Panel (if equipped) and cover socket with square foam (similar to Fig. 11A).
  - b) Tape mounting area to protect panel.
  - c) Tape template at location shown in Fig. 15A.
  - d) Using punch tool, prepare hole locations to be drilled by punching through them. Remove Template.
  - e) Using Driver Footwell Lamp Hole location template A, mark and drill 1/8" pilot hole.
  - f) Finish hole with 3/16" (8mm) drill bit and deburr.

# INSTALLATION INSTRUCTIONS - Accent Lighting Kit

## INSTALLATION PROCEDURE:



- g) Remove tape placed in Step b) before attaching footwell lamp to Instrument Lower Cover.
- h) Use two 5.2mm dia. push-pin fasteners supplied in kit to secure lamp to Instrument Lower Cover.

### NOTE:

**Make sure to drill no more than 1/2" deep. Make sure not to drill into the L Plate/bracket of the buzzer (if any). Hold harness (if any) away from panel when drilling.**

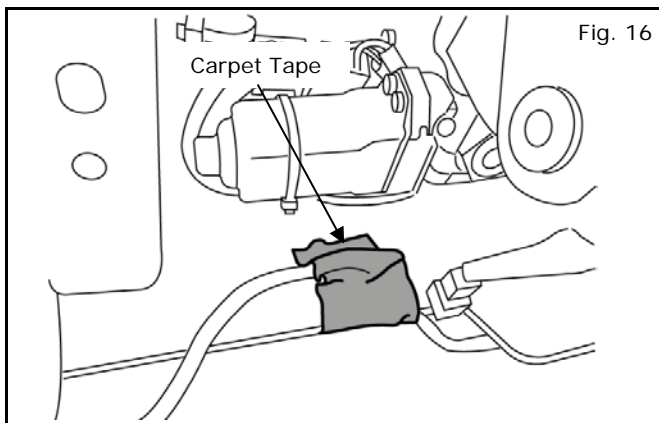

- 16) Routing DR side Footwell Lamp Harness
  - a) Route lamp harness up behind panel and tape it using Carpet Tape to the inside of Instrument Lower panel, as shown.

## INSTALLATION PROCEDURE:

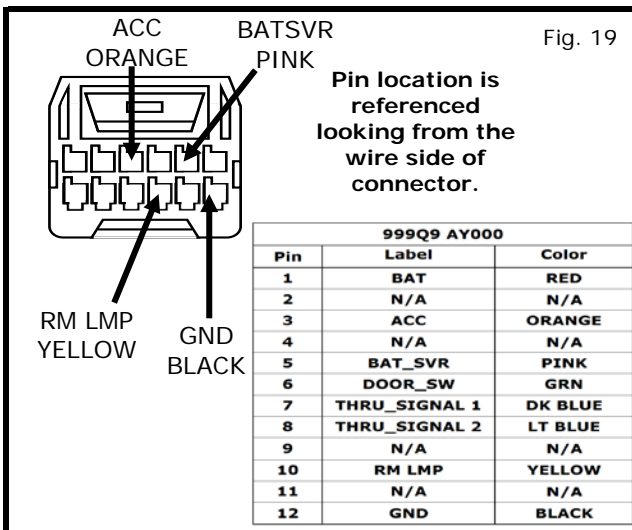
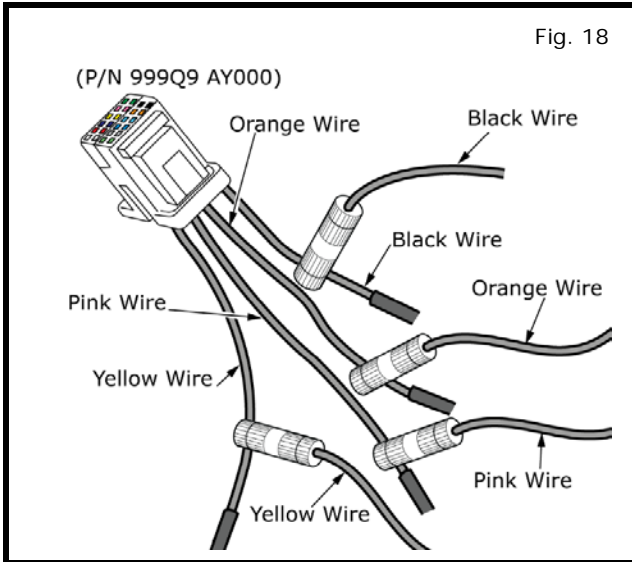
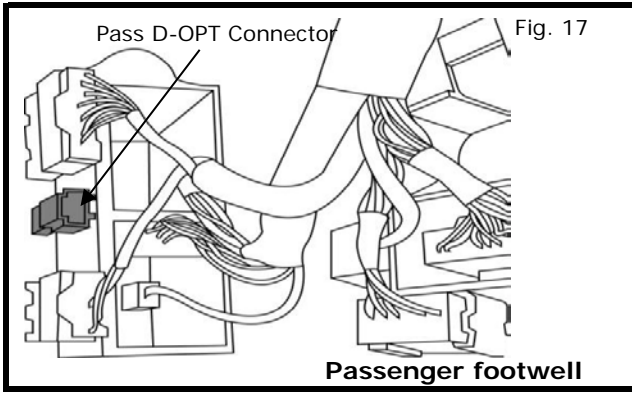

- 17) Locating Passenger D-Opt Connector.
- Locate passenger side D-Opt Connector behind glove box on right side of footwell as shown in Fig. 17. If not present there, D-OPT connector can be located on the bar under glove box tied to LED harness

### NOTE:

**A previously installed accessory may be present. If so, carefully remove accessory connector harness from D-Opt connector before posi-tapping. It is recommended that all posi-tapping be completed before reattaching accessory connector harness to plug.**

- 18) Connect lighting power harness to accessory connector harness using posi-taps.
- Connect **BLACK** wire from power harness to **BLACK (GND)** wire on accessory connector harness.
  - Connect **ORANGE** wire from power harness to **ORANGE (ACC)** wire on accessory connector harness.
  - Connect **PINK** wire from power harness to **PINK (BATT\_SAVER)** wire on accessory connector harness.
  - Connect **YELLOW** wire from power harness to **YELLOW (ROOM\_LAMP)** wire on accessory connector harness.
  - Tape back **BROWN** wire from power harness to power harness - **not used**

- 19) Accessory service connector pin out reference is shown. P/N 999Q9 AY000

### NOTE:

- A previously installed accessory may be present. If so, carefully remove the accessory connector harness from the accessory connector plug before posi-tapping.**
- It is recommended that all posi-tapping be completed before reattaching the accessory connector harness to the plug.**
- If there is not a previously installed accessory, remove the dummy plug in connector. See detail.**
- Wrap the harness side of the connector in foam tape as to allow the accessory connector to be connected and disconnected.**

## INSTALLATION PROCEDURE: POSI-TAP

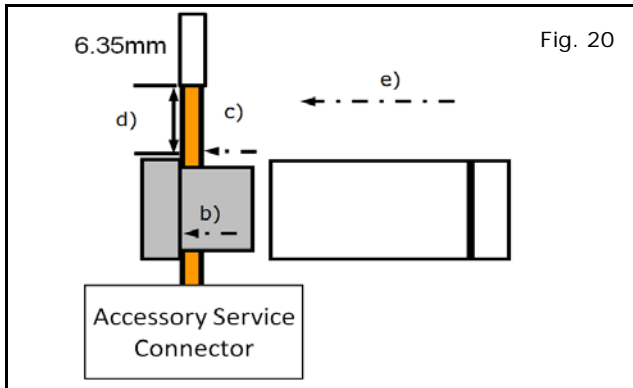

- 20) Posi-tapping an Accessory service wire (Fig. 20)
- Identify and confirm correct wire in the Accessory Service Connector to be tapped.
  - Remove cap (slot side) from tap body.
  - Slide cap around single accessory wire.
  - Position cap  $\geq 6.35\text{mm}$  (0.25in) away from the heat shrink end of Accessory Service Connector (measurement for first posi-tap installed on the circuit).
  - Tighten the tap **TIGHT** with finger pressure.
  - Tighten by another quarter turn.

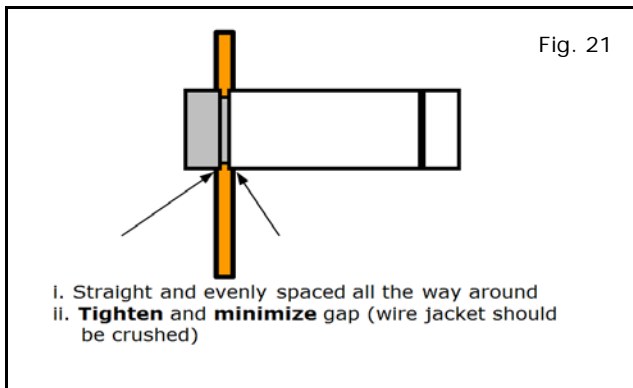

- 21) Inspecting the tap for correct installation (Fig. 21).
- Pull on the wire lightly to ensure connection.
  - Inspect the tap to ensure correct installation.
  - Test the signal to ensure that it is working properly.

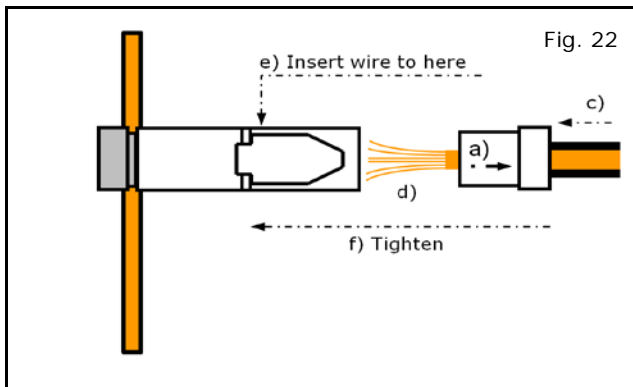

- 22) Tap accessory wire (Fig. 22).
- Remove tap (non-pierce) side from tap.
  - Remove the protective stub from the wire.
  - Insert wire through the non-pierce side opening.
  - Spread the individual strands into fan shape.
  - Insert wire into the tap body and ensure that it is all the way in.
  - Tighten the tap **TIGHT** with finger pressure.
  - Tighten by another quarter turn.

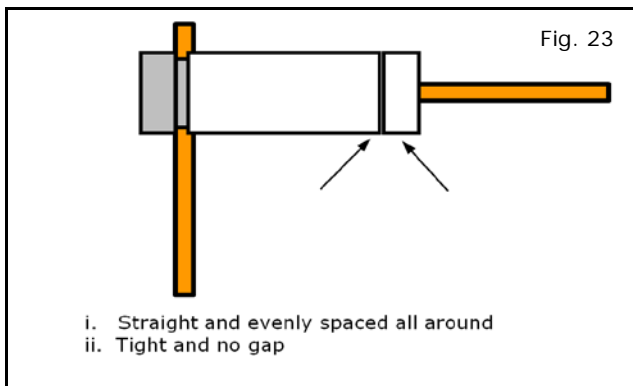

- 23) Confirm the tapped accessory wire.
- Pull on the wire lightly to ensure connection.
  - Inspect the tap to ensure correct installation as shown in Fig. 23.

## INSTALLATION PROCEDURE: POSI-TAP

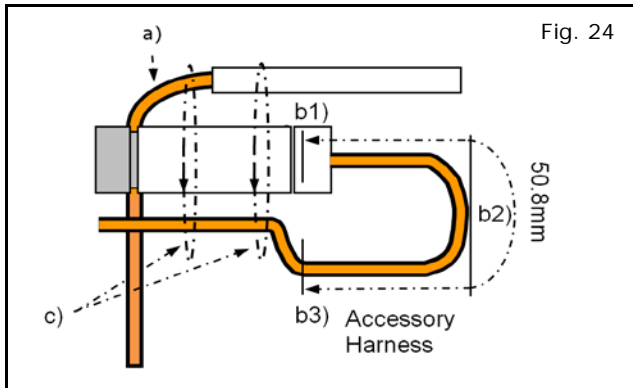

- 24) Forming strain relief loop - required (Fig. 24).
- a) Gently bend end of pierced wire (where it exits cap) down towards body of posi-tap.
  - b) On tapped side wire; starting at point b1), measure 50mm to point b2). Make first bend of loop b2), half measured distance - 25mm, and up toward body of posi-tap, make second bend of loop b3).
  - c) Secure pierced wire on heat shrink side and tapped wire to body of tap with electrical tape ( $\geq 2$  revolutions).

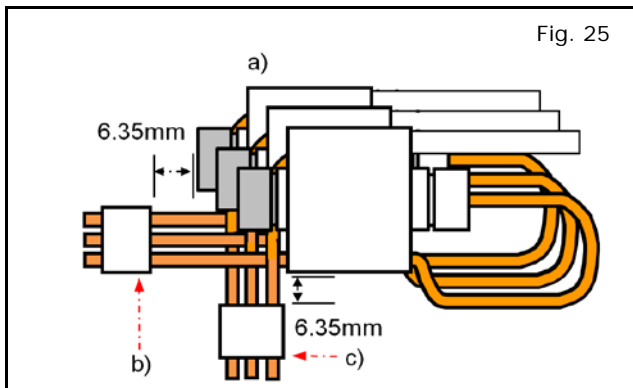

- 25) Securing multiple accessory taps (Fig. 25).
- a) Tapped accessories (wires already secured to tap bodies) are stacked in a stagger on top of each other as shown in Fig a).
  - b) Secure tapped wires on connector side of posi-taps to each other with electrical tape ( $\geq 2$  revolutions) at a distance of  $\geq 6.35$ mm as shown in Fig b).
  - c) Pierced wires of posi-taps are secured to each other with electrical tape ( $\geq 2$  revolutions) at a distance of  $\geq 6.35$ mm (0.25in) as shown in Fig c).

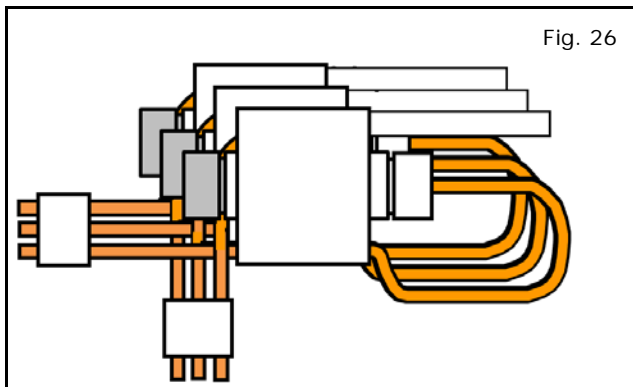

- 26) Securing multiple accessory taps (Fig. 26).
- a) Make sure the accessory taps have been wrapped appropriately as detailed previously and as shown.

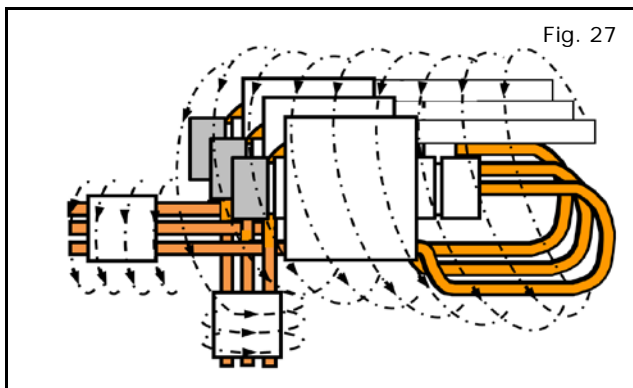

- 27) Securing multiple accessory taps.
- a) Starting at heat shrink; firmly wrap posi-tap bundle with electrical tape or non-adhesive wire harness tape, making sure to overlap previous revolution.
- Note:** If using non adhesive tape secure at the of wrap with electrical tape  $\geq 2$  revolutions.

## INSTALLATION PROCEDURE: POSI-TAP

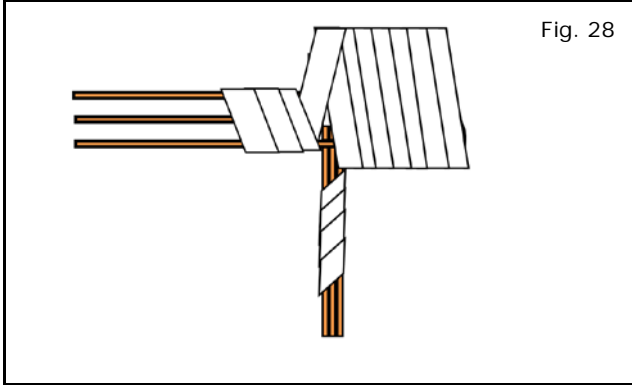

- 28) Securing multiple accessory taps  
a) Make sure the finished wrap looks similar to Fig. 28.

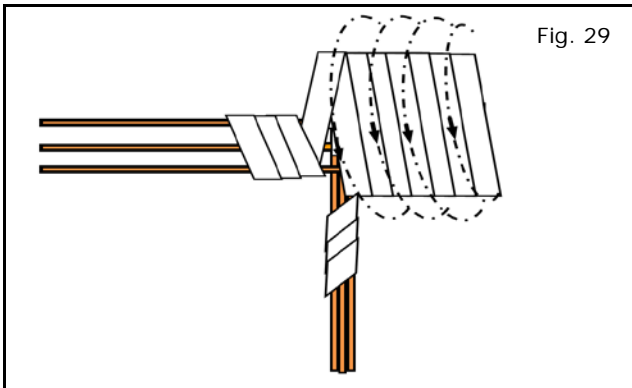

- 29) Foam wrap for posi-tap bundle (foam strips)  
a) Wrap the posi-tap bundle with foam tape, following a pattern similar to the electrical tape, making the best use of foam strips provided.

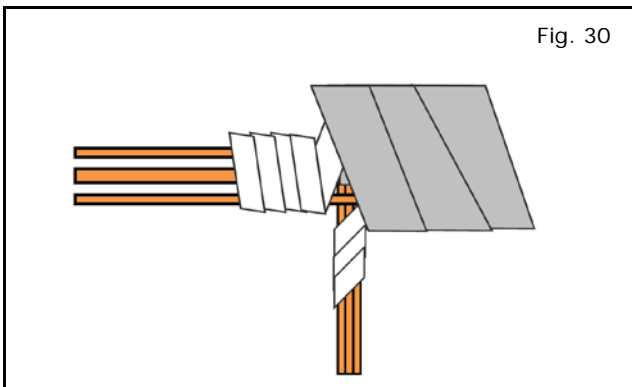

- 30) Finished foam wrap for bundle (strips-top view)  
a) Make sure the finished wrap looks similar to Fig. 30.

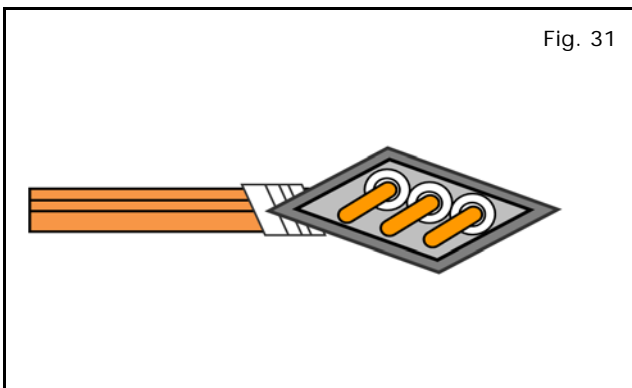

- 31) Finished foam wrap for bundle (strips-side view)  
a) Make sure the finished wrap looks similar to what is shown in Fig. 31.



# INSTALLATION INSTRUCTIONS - Footwell Lighting Kit

## INSTALLATION PROCEDURE:

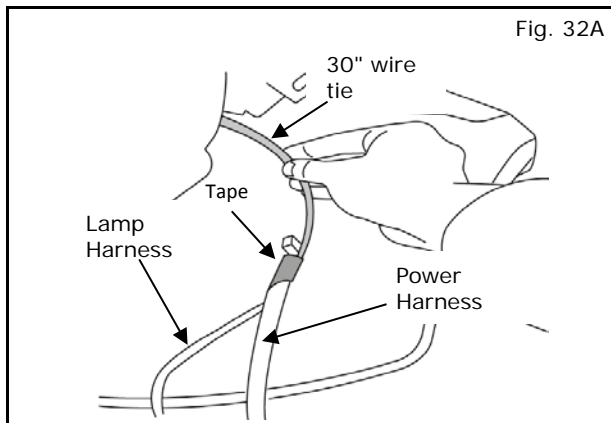

32) Routing Lamp Harness & Power Harness through Center Console.

a) Tape & Route Wire Harnesses connectors into center console using 30" wire, as shown in Fig. 32A

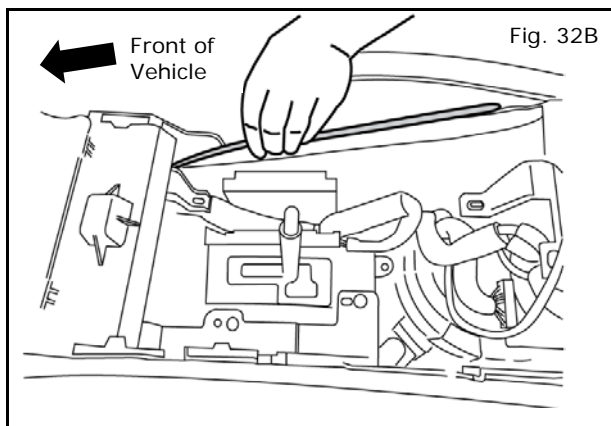

b) Route Wire Harnesses through center console using 30" wire tie, as shown in Figs. 32B .

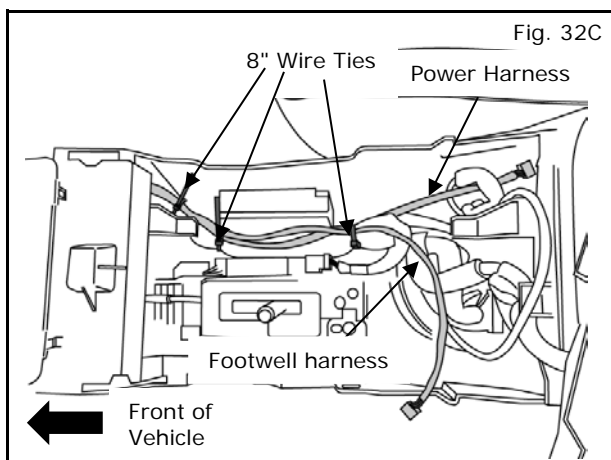

b) Tie using 8" wire ties at locations shown.

e) Route harnesses along the center console to the ECU on the Passenger side wall trim panel.

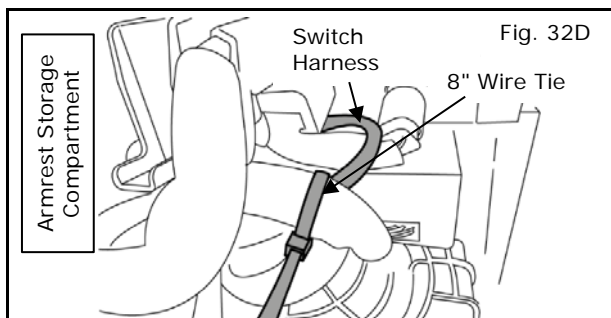

f) Tie Switch harness from Step 36 to the vehicle harness and route it along the passenger side (Fig. 32D).

### NOTE:

**Step 32(f) is for informational purpose only at this point.**

# INSTALLATION INSTRUCTIONS - Accent Lighting Kit

## INSTALLATION PROCEDURE:

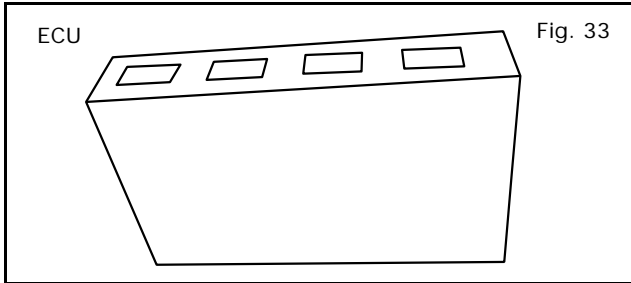

- 33) ECU connection port identification (Fig. 33).
- Four 5 pin OUT ports.
  - Plug footwell lamps into **5 pin OUT 2 port**.
  - Plug power harness into 7 pin VEHICLE port.
  - Plug switch into 4 pin SWITCH port.

34) Open center armrest storage compartment. Trim shape of compartment will either be similar to Fig. 34a or 34b.

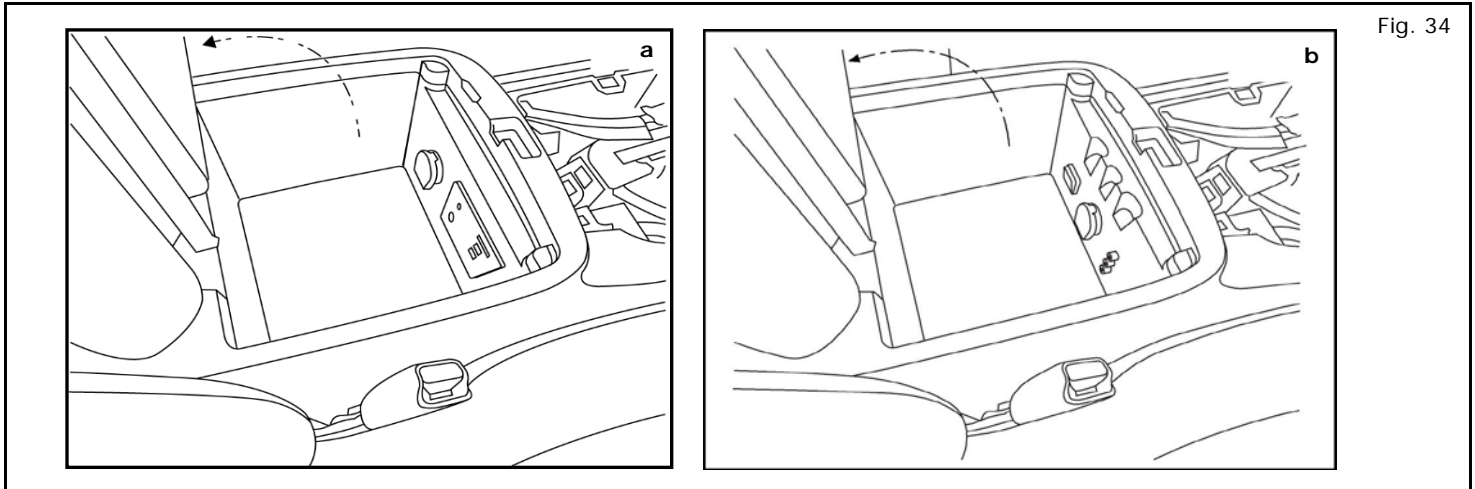

35) Depending on compartment trim shape, apply template "A-1" or "A-2" to armrest compartment as shown in Figs. 35a or 35b. Template should be positioned with letter "A-1" or "A-2" in upper left hand corner. Using punch tool, prepare hole locations to be drilled by punching through them. Remove Template. Using Switch Hole location template (Figs. 35a or 35b), mark and drill 1/8" pilot hole. Finish hole with 3/8" drill bit and deburr. Clean inner surface using Alcohol wipe

### NOTE:

- Print template at actual size.
- Deburr hole after drilling. Be sure to clean up compartment after drilling.

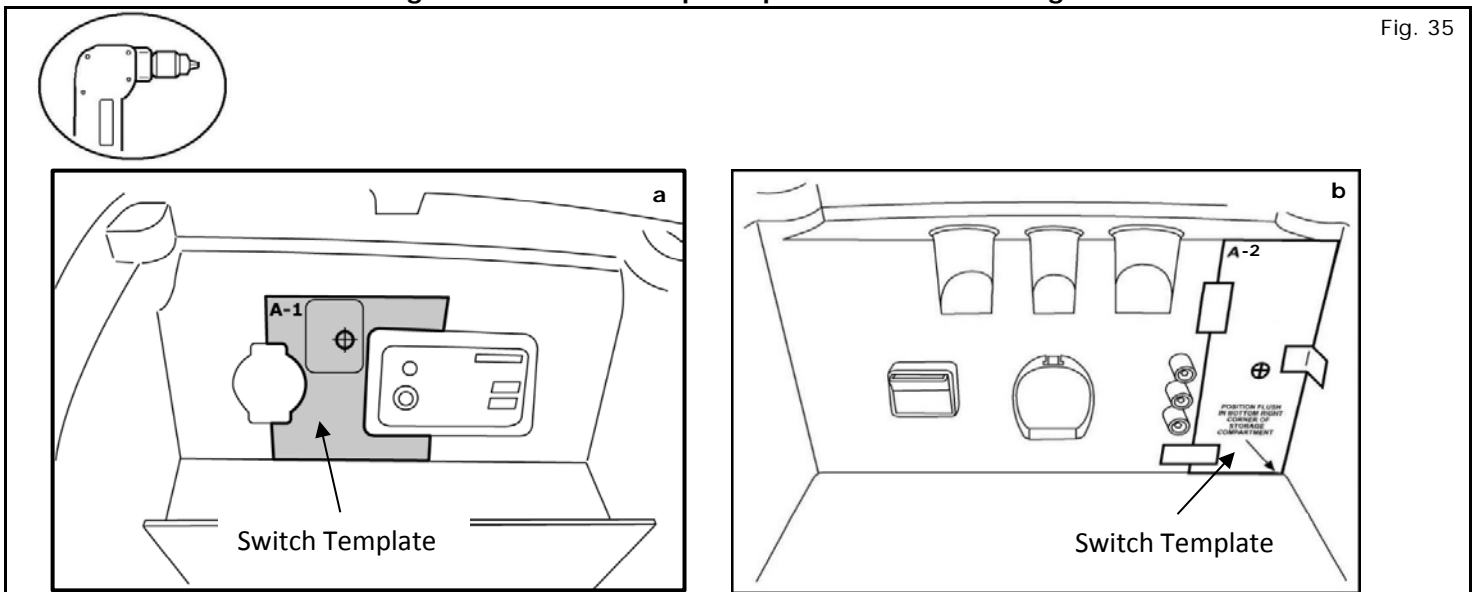

# INSTALLATION INSTRUCTIONS - Accent Lighting Kit

## INSTALLATION

### 36) Install switch.

- a) Peel adhesive backing from switch.
- b) Depending on the trim level (Fig 36a or 36b), Insert harness connector in the drilled hole and Route switch harness through hole from inside of Glove box into center console
- c) Place template along the outline to verify placement of switch
- d) Contact switch adhesive to console. Press firmly and hold. **Apply 15 lbs. pressure for 20 seconds.**
- e) Route harness through the bin into the center console to the passenger side where control module will be mounted.
- f) Tie Switch Harness as suggested in Step 32(f)

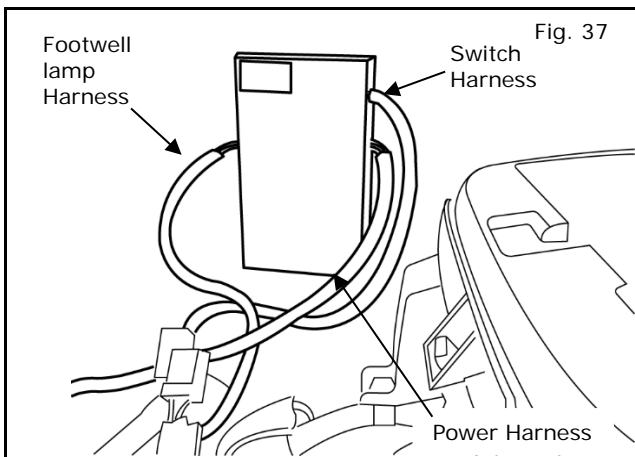
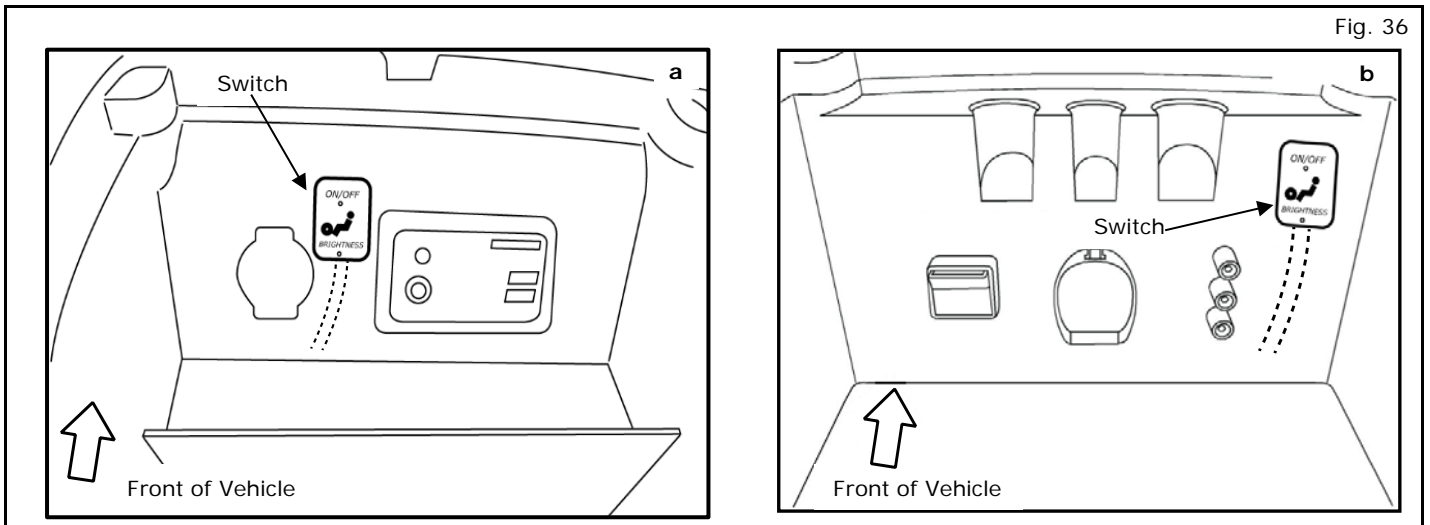

### 37) ECU Connection (Fig. 37)

- a) Route power harness to ECU. Plug power harness into 7 pin VEHICLE port. Press firmly, listen for "Click" and give a slight tug to check.
- b) Route switch harness to ECU. Plug switch harness into 4 pin SWITCH port. Press firmly, listen for "Click" and give a slight tug to check.
- c) Route Front Footwell Lamp Harness to ECU. Plug Lamp harness into 5 pin **OUT2 port**. Press firmly, listen for "Click" and give a slight tug to check.

# INSTALLATION INSTRUCTIONS - Accent Lighting Kit

## INSTALLATION PROCEDURE:

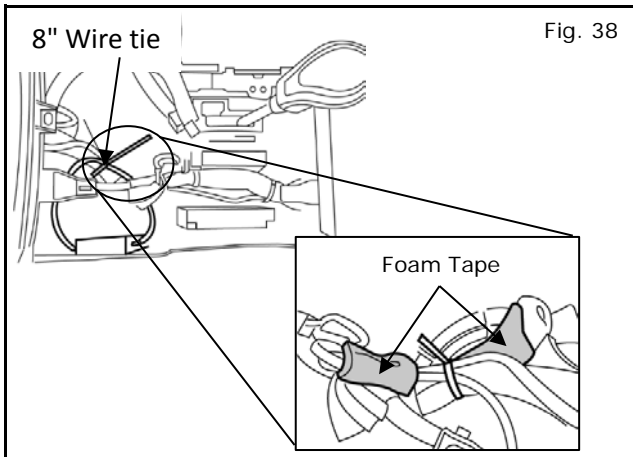

### 38) Centre Console Harness Tying & Bundling

- a) Bundle & Tie Power harness & Light Harness using 8" wire tie & foam tape using 60 x 90mm Foam tapes, as shown in the zoomed out frame in Fig. 38
- b) Wire tie any additional switch harness to the existing bundle using 8" wire tie, if needed

### 39) ECU Placement

- a) Clean the inner surface of side panel using Alcohol wipe. (Panel along **Passenger side for QX60 - Fig 39a** & Panel along **Driver side for Pathfinder - Fig 39b**)
- b) Place the ECU in the location shown in Fig. 39. **Apply 15 lbs. pressure for 20 seconds evenly on the Upper face of the ECU.**

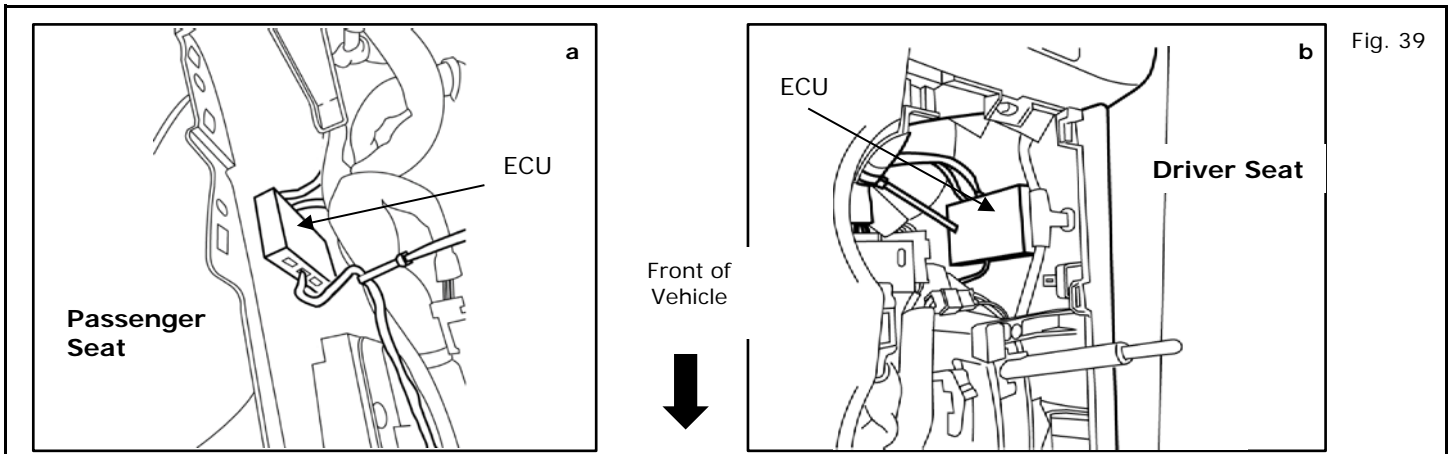

- 40) Bundle & Tie wrap (using 8" wire tie) any extra harness in the center console to avoid rattling & squeaking.

#### NOTE:

**Make sure to tighten all wire ties and clip off the extra ends after this step.**

- 40) Reinstall console finisher panel.
  - a) Check connections on finisher panel harness.
  - b) Plug the connector back under center console.
  - c) Position finisher panel over console.
  - d) Align clips and lower into position.
  - e) Press down on finisher panel to engage clips.
- 41) Reinstall Gear selector knob
  - a) Check clip for proper installation on knob.
  - b) Place knob on lever and press down.
- 42) Reinstall all the remaining trim panels and glove box.

#### ACCESSORY CHECK:

- Connect the battery negative terminal and tighten the nut to 5.4 N-m (47.8 lb-in)
- Check all **Critical Installation Steps**.
- Verify all wiring is secure and not exposed.
- Trim all excess cable ties flush.
- Turn ignition switch to "**ACC**" position.
- Confirm accessory main features and functions. Confirm cup holder, bin and food well lamps illuminate. Diagnostic flow chart is available on the next page for troubleshooting. (For complex electrical accessory, a diagnostic flow chart is required.)
- Check all vehicle electrical systems that the accessory interfaces with.
  - Vehicle electrical system 1 (Must for pre-wiring, overlay harness, and Posi-Tap)
  - Vehicle electrical system 2 (Electrical system(s) where the accessory connects.)

#### RE-INSTALLATION OF REMOVED PARTS:

- Re-install all removed vehicle parts. Refer to the vehicle service manual as necessary.

### CAUTION

- Use caution when re-installing interior components to avoid damage, scratches, or breaking of mounting clips. Refer to the vehicle service manual for more information.

#### FINAL INSPECTION:

- Verify re-installed trim parts for proper flush fit (no gap, no waviness, etc.).
- Verify all clips are fully engaged and locked.
- Verify re-installed trim parts are free from cracks, scratches or stress marks.
- Verify vehicle headliner, seat, steering wheel, center console, floor carpets, etc. are not soiled.
- Verify interior and exterior is not damaged.
- Turn ignition switch to "ON" and confirm proper operation of Vehicle Systems
  - If equipped, verify all window and sunroof one touch operation and perform the reset procedure if necessary. Refer to the vehicle service manual for more details.
  - Confirm proper audio function (AM, FM, SAT, CD and AUX).

**FINAL INSPECTION:**

- Start engine and verify that there are no new Diagnostic Trouble Code. Turn ignition switch to "**OFF**".
- Place the Owner Manual, Quick Reference Guide, and/or other Manual in the glove box.
- If this vehicle will be returned to a dealer lot or showroom for an extended period of time, be sure the extended storage switch is placed in the "inventory" position. Refer to the Extended Storage Switch verbiage at the beginning of the 'INSTALLATION PROCEDURE' section.
- Re-program radio presets and other vehicle settings to the recorded settings. No need to do this step if the extended storage switch is placed in the "inventory" position.

# INSTALLATION INSTRUCTIONS - Interior Accent Lighting Kit

## CHECK OUT

- (1) Shut all doors on the vehicle.
- (2) Wait until all interior lamps go out.
- (3) Turn on **ACCESSORY**.
- (4) Verify that both Footwell Lights, Cupholder Lights, Bin Light and Switch light up and that switch changes light intensity.
- (5) Check the trim for a proper, flush fit after re-installing the interior components.
- (6) Clean the interior of the vehicle.
- (7) Inspect the vehicle interior and exterior for damage.
- (8) Check and clear trouble codes (DTC).
- (9) If this vehicle will be returned to a dealer lot or showroom for an extended period of time, be sure the extended storage switch is placed in the "inventory" position. (Refer to section 9 - Vehicle Preparation)
- (10) If vehicle is NOT going into storage, reset the radio presets to the recorded settings.

**Note: When diagnosing electrical system problems, first disconnect the accessory connectors and note effect on system. Continue the investigation with the accessory connectors disconnected. Remember to reconnect the accessories when the investigation is complete.**

Posi-Tap™ is protected by patent # 5,228,875 5,695,369 5,868,589 6,692,313 Jap 2881414 Aus 708700 Tia 103534 Can 2204826 Mex 200626 Korea 477279 China Z197105562.9 & others pending.



# INSTALLATION INSTRUCTIONS - Interior Accent Lighting Kit

## BILL OF MATERIALS

### Interior Accent Lighting Kit - T99F3 6SA00

	Parts Contained in Bag Labelled 'Installation Kit'.	Quantity
1	Control Module	1
2	Front Footwall Lights and Harness Assembly - LED Light Engines with Light Pipes	1
3	2-Button Brightness Selection Switch and Harness	1
4	Power Harness/ Vehicle Interface Harness	1
5	Hardware Kit	1
6	Foam Tape, 60X90MM Polyurethane	3
7	Wire tie, 8 in. Nylon 6,6, Blk (203 X 4.75 X 1.27 MM)	7
8	Wire Tie, 30 in. Nylon 66, White (762 X 8.8 X 1.95 MM)	1
9	3M Beta Tape 5073, 48 X 89MM POLYURATHANE	2
10	Alcohol Wipes	2
11	Posi Taps	4
12	Push Pin Clip 8mm dia, Nylon 6/6	1
13	Push Pin Clip 5.2mm dia, Nylon 6/6	2
14	Lamp Foam, 25 x 25 mm	2
15	Customer Quick Reference Guide	1
16	II Replacement Template/Parts List Card	1

# ACCENT LIGHTING KIT



Note: Pin location is referenced looking into wire side of connector.

TH12FW-NH

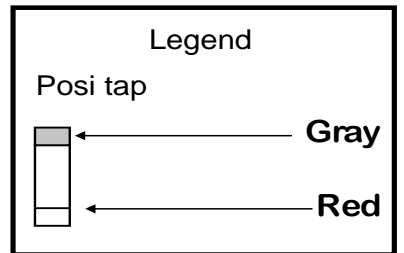
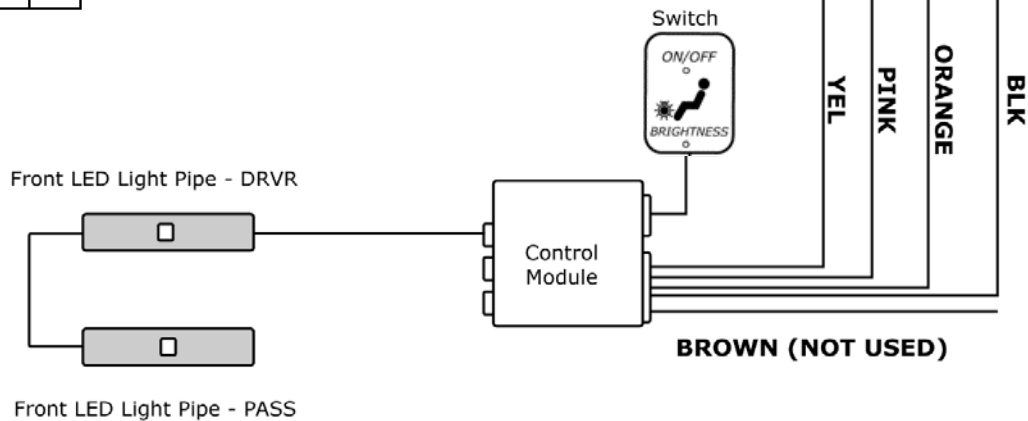
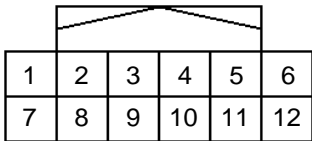

**Page Intentionally Left Blank**

# DRIVER FOOTWELL LIGHT HOLE LOCATION

IMPORTANT : WHEN PRINTING FROM PDF SELECT ACTUAL SIZE

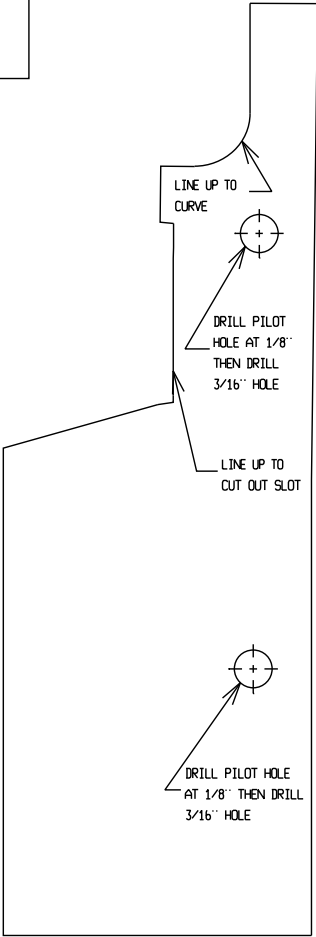

1in  
SQUARE

**Page Intentionally Left Blank**

# PASSENGER FOOTWELL LIGHT HOLE LOCATION

IMPORTANT : WHEN PRINTING  
FROM PDF SELECT ACTUAL SIZE

1in  
SQUARE

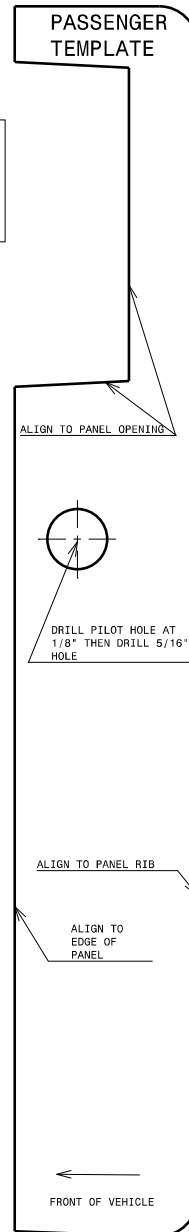

**Page Intentionally Left Blank**



SWITCH HOLE LOCATION TEMPLATE

1in  
SQUARE

IMPORTANT : WHEN PRINTING  
FROM PDF SELECT ACTUAL SIZE

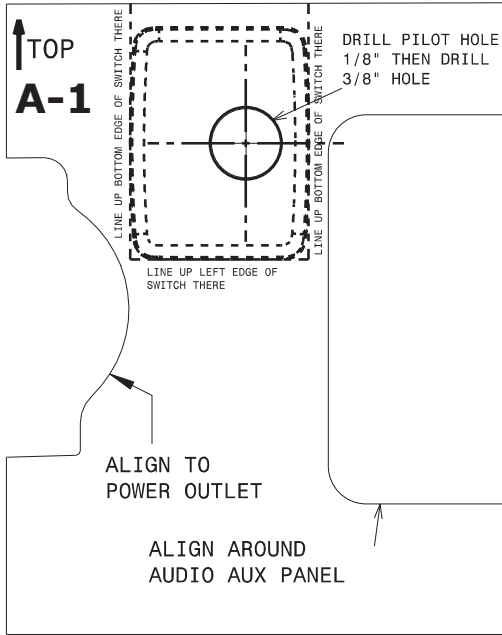

**Page Intentionally Left Blank**

SWITCH HOLE LOCATION TEMPLATE

IMPORTANT : WHEN PRINTING  
FROM PDF SELECT ACTUAL SIZE

**SCALE**  
1 inch

 10mm

**A-2**



POSITION FLUSH  
IN BOTTOM RIGHT  
CORNER OF  
STORAGE  
COMPARTMENT

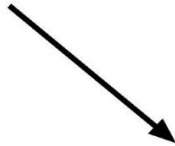

**Page Intentionally Left Blank**